



Labour  
Force  
Survey

**User Guide**

**VOLUME 9a – LFS Eurostat Ad Hoc Modules, 2008 to 2019**

## Contents

### Section 1: Technical items

Regulations underpinning Eurostat LFS ad hoc modules 1999 to 2019	-	-	-	-	-	-	-	-	3
Ad hoc module sub-sample description	-	-	-	-	-	-	-	-	4
Minimum age thresholds on the UK LFS and EU LFS	-	-	-	-	-	-	-	-	4
Availability of ad hoc module data	-	-	-	-	-	-	-	-	5

### Section 2: Details of ad hoc modules

2019 ad hoc module ‘Work organisation and work time arrangements’										
Specification	-	-	-	-	-	-	-	-	-	6
Flowcharts	-	-	-	-	-	-	-	-	-	9
Documentation	-	-	-	-	-	-	-	-	-	20
2018 ad hoc module ‘Reconciliation between family and work life’										
Specification	-	-	-	-	-	-	-	-	-	30
Flowcharts	-	-	-	-	-	-	-	-	-	33
Documentation	-	-	-	-	-	-	-	-	-	45
2017 ad hoc module ‘Self-employment’										
Specification	-	-	-	-	-	-	-	-	-	56
Flowcharts	-	-	-	-	-	-	-	-	-	60
Documentation	-	-	-	-	-	-	-	-	-	71
2016 ad hoc module ‘Young people on the labour market’										
Specification	-	-	-	-	-	-	-	-	-	79
Flowcharts	-	-	-	-	-	-	-	-	-	83
Documentation	-	-	-	-	-	-	-	-	-	102
2014 ad hoc module ‘Labour market situation of migrants and their immediate descendants’										
Specification	-	-	-	-	-	-	-	-	-	110
Flowcharts	-	-	-	-	-	-	-	-	-	113
Documentation	-	-	-	-	-	-	-	-	-	123
2013 ad hoc module ‘Accidents at work and other health related problems’										
Specification	-	-	-	-	-	-	-	-	-	127
Flowcharts	-	-	-	-	-	-	-	-	-	131
Documentation	-	-	-	-	-	-	-	-	-	143
2012 ad hoc module ‘The transition from work to retirement’										
Specification	-	-	-	-	-	-	-	-	-	145

Flowcharts	-	-	-	-	-	-	-	-	-	147
Documentation	-	-	-	-	-	-	-	-	-	169
2011 ad hoc module ‘The employment of disabled people’										
Specification	-	-	-	-	-	-	-	-	-	186
Flowcharts	-	-	-	-	-	-	-	-	-	190
Documentation	-	-	-	-	-	-	-	-	-	203
2010 ad hoc module ‘Reconciliation between work and family life’										
Specification	-	-	-	-	-	-	-	-	-	217
Flowcharts	-	-	-	-	-	-	-	-	-	220
Documentation	-	-	-	-	-	-	-	-	-	231
2009 ad hoc module ‘The entry of young people into the labour market’										
Specification	-	-	-	-	-	-	-	-	-	238
Flowcharts	-	-	-	-	-	-	-	-	-	240
Documentation	-	-	-	-	-	-	-	-	-	255
2008 ad hoc module ‘Labour market situation of migrants and their immediate descendants’										
Specification	-	-	-	-	-	-	-	-	-	261
Flowcharts	-	-	-	-	-	-	-	-	-	264
Documentation	-	-	-	-	-	-	-	-	-	276

### Section 3: Annexes

I - ISO country classification in the LFS from 2012 onwards	-	-	-							281
II - CRY07 to ISO country look-up	-	-	-	-	-	-	-	-	-	285
IIIa - SOC2000 to ISCO-88 (COM) look-up	-	-	-	-	-	-	-	-	-	290
IIIb – SOC2010 to ISCO-08 notes	-	-	-	-	-	-	-	-	-	296
IVa - Eurostat variable names and their respective UK LFS names (2012-2013)	-	-								297
IVb - Eurostat variable names and their respective UK LFS names (2014)	-	-								300
IVc - Eurostat variable names and their respective UK LFS names (2015)	-	-								303
IVd - Eurostat variable names and their respective UK LFS names (2016)	-	-								306

## SECTION 1: Technical Items

## 1 Regulations underpinning Eurostat LFS ad hoc modules 1999 to 2018

Under Regulation (EC) No [577/98](#), EuroStat includes a number of variables each year which provide information on aspects of the labour market that do not form part of the standard questionnaire. This set of variables, constitute an "ad hoc module".

Regulations adopting the programme of ad hoc modules	Regulations adopting the specifications	Ad hoc module description	Year
<p><a href="#">Regulation 1397/2014</a> of 22 October 2014 amending Regulation (EU) No 318/2013 adopting the programme of ad hoc modules (2016 to 2018).</p> <p><a href="#">Regulation 0318/2013</a> of 8 April 2013 adopting the programme of ad-hoc modules (2016 to 2018).</p>		Work organisation and work time arrangements	2019
		Reconciliation between Work and Family Life	2018
		Self employment	2017
	Commission Implementing Regulation (EU) 2015/459 specifying the technical characteristics of the 2016 ad hoc module on young people on the labour market provided for by Council Regulation (EC) No 577/98	Young people on the labour market	2016
<p><a href="#">Regulation 0220/2010</a> of 16 March 2010 adopting the programme of ad hoc modules (2013 to 2015).</p>	N/A	Work organisation and working arrangements <b>NB – optional, not run in UK</b>	2015
	By <a href="#">ESS agreement</a>	Labour market situation of migrants and their immediate descendants	2014
	By <a href="#">ESS agreement</a>	Accidents at work and work-related accidents	2013
<p><a href="#">Commission Regulation (EC) No 365/2008</a> of 23 April 2008 adopting the programme of ad hoc modules covering the years 2010 to 2012</p>	<a href="#">Regulation (EU) No 249/2011</a>	Transition from work into retirement	2012
	<a href="#">Regulation (EU) No 317/2010</a>	Employment of disabled people	2011
	Commission Regulation (EC) No 20/2009	Reconciliation between work and family life	2010
<p><a href="#">Commission Regulation (EC) No 384/2005</a> of 7 March 2005 adopting the programme of ad hoc modules, covering the years 2007 to 2009</p>	<a href="#">Commission Regulation (EC) No 207/2008</a>	Transition from school to work life	2009
	<a href="#">Commission Regulation (EC) No 102/2007</a>	Labour Market situation of migrants and the immediate descendants of migrants	2008
	<a href="#">Commission Regulation (EC) No 391/2008</a> (amendment concerning BG and RO)		
	<a href="#">Commission Regulation (EC) No 341/2006</a>	<a href="#">Accidents at work and work-related health problems</a>	2007
<p><a href="#">Commission Regulation (EC) No 246/2003</a> of 10 February 2003 adopting the programme of ad hoc</p>	<a href="#">Commission Regulation (EC) No 388/2005</a>	Transition from work into retirement	2006
	<a href="#">Commission Regulation (EC) No 29/2004</a>	Reconciliation between work and family life	2005

modules, covering the years 2004 to 2006	<a href="#">Commission Regulation (EC) No 247/2003</a>	Work organisation and working time arrangements	2004
Commission Regulation (EC) No 1626/2000 of 24 July 2000 adopting the programme of ad hoc modules, covering the years 2001 to 2004	<a href="#">Commission Regulation (EC) No 1313/2002</a>	Lifelong learning	2003
	<a href="#">Commission Regulation (EC) No 1566/2001</a>	Employment of disabled people	2002
	<a href="#">Commission Regulation (EC) No 1578/2000</a>	Length and patterns of working time	2001
Commission Regulation (EC) No 1924/1999 of 8 September 1999 adopting the programme of ad hoc modules, covering the years 2000 to 2002	<a href="#">Commission Regulation (EC) No 1925/1999</a>	Transition from school to working life	2000
	<a href="#">Commission Regulation (EC) No 1571/98</a>	Accidents at work and occupational diseases	1999

For more information on Eurostat ad hoc modules: -

[http://circa.europa.eu/irc/dsis/employment/info/data/eu\\_lfs/LFS\\_MAIN/LFS/lfs\\_regulations.htm](http://circa.europa.eu/irc/dsis/employment/info/data/eu_lfs/LFS_MAIN/LFS/lfs_regulations.htm)

Explanatory notes and model questionnaires for the Eurostat ad hoc modules are available here:

[http://ec.europa.eu/eurostat/statistics-explained/index.php/EU\\_labour\\_force\\_survey\\_-\\_ad\\_hoc\\_modules](http://ec.europa.eu/eurostat/statistics-explained/index.php/EU_labour_force_survey_-_ad_hoc_modules)

As part of these regulations, Eurostat invite Member States to apply for grants to support the preparation, data collection and delivery of these ad hoc modules and supporting documentation. As such, the Eurostat ad hoc modules on the Labour Force Survey have been funded by Eurostat each year since 2016.

## 2 Ad hoc module sub-sample description

Up to 2008 the Eurostat LFS ad hoc modules were run on all waves in one quarter. From 2002 to 2008 the relevant quarters were:

2002 Q1 March - May  
 2003 Q1 March - May  
 2004 Q1 March - May  
 2005 Q1 March – May  
 2006 Q2 April – June  
 2007 Q1 January – March  
 2008 Q2 April – June

(NB – the UK LFS moved from ‘seasonal’ to ‘calendar’ quarters in 2006)

In 2009 the UK LFS adopted a ‘wave approach’ to the ad hoc module sub-sample; specifically, wave 1 in all quarters. Consequently the complete ad hoc module sample is achieved by combining wave 1 data from all four quarters and applying the specific ‘annual’ weight COEFFY (EWEIGH).

## 3 Minimum age thresholds on the UK LFS and EU LFS

The UK LFS collects only demographic data (age, sex, nationality, family relationship and so on) for respondents aged below 16. Therefore all other variables have a default minimum age threshold of 16 – except those which have a specific under-16 category, e.g. employment status. For the EU LFS Eurostat define the minimum age threshold for all questions as 15. Consequently in EU LFS data UK 15 year olds will have a non-response value for all variables other than the demographic variables mentioned above. ONS recommends that users employ an appropriate age filter in analysis of UK data in the EU LFS to ensure that 15 year olds do not inflate the non-response counts and percentages

#### **4 Availability of Eurostat ad hoc module data**

Eurostat ad hoc module variables and associated weights are available on APS person datasets from 2009 onwards, Jan-Dec periods only. APS person datasets can be accessed via the UK Data Service (UKDS).

LFS/APS data generally is made available through the UK Data Service. An End User Licence is an agreement between the user and the University of Essex to provide users with the right to use the data held at the Data Service. The End User Licence dataset can be accessed through the UK Data Service (UKDS) website <https://www.ukdataservice.ac.uk/manage-data/legal-ethical/access-control>

A more detailed file can be accessed if Approved Researcher Status is sought and agreed. More information on the UK Data Service and the Approved Researcher process can be found on the UK Data Service website <https://www.ukdataservice.ac.uk/get-data/how-to-access>

## Specifications of the 2019 ad hoc module on work organisation and work time arrangements

Column	Code	Description	Filters/remarks
		<b>SUB-MODULE 1: FLEXIBILITY OF WORKING TIMES</b>	
211	VARIWT	<p style="text-align: center;"><b>Variable working time</b></p> <p><i>How is determined the start and end of the working time in the main job</i></p> <p>1 Worker can fully decide working time                      2 Worker can decide working time with certain restrictions                      3 Employer or organisation mainly decides working time                      9 Not applicable (not included in the filter)                      Blank No answer / Don't know</p>	WSTATOR = 1, 2
212	FREEHOUR	<p style="text-align: center;"><b>Freedom to take hours off</b></p> <p><i>Possibility to take one or two off in the main job for personal or family matters within one working day</i></p> <p>1 Very easy                      2 Quite easy                      3 Quite difficult                      4 Very difficult                      9 Not applicable (not included in filter)                      Blank No answer / Don't know</p>	VARIWT = 2,3,
213	FREELEAV	<p style="text-align: center;"><b>Freedom in taking leave</b></p> <p><i>Possibility to take in the main job one or two days of leave within three working days</i></p> <p>1 Very easy                      2 Quite easy                      3 Quite difficult                      4 Very difficult                      9 Not applicable (not included in filter)                      Blank No answer / Don't know</p>	WSTATOR = 1, 2
214	FLEXWT	<p style="text-align: center;"><b>Expected flexibility in working time</b></p> <p><i>Frequency to which the worker has to face unforeseen demands for changed working time in the main job</i></p> <p>1 At least once a work                      2 Less than every week but at least once a month                      3 Less than every month or never                      9 Not applicable (not included in the filter)                      Blank No answer / Don't know</p>	WSTATOR = 1,2

**Specifications of the 2019 ad hoc module on work organisation and work time arrangements**

Column	Code	Description	Filter/Remarks
215	AVAIFREE	<p style="text-align: center;"><b>Available for work in free time</b></p> <p><i>Worker was contacted during leisure time in the last two months to take action before the next working day for the main job</i></p> <p>1 Was not contacted in the last two months                      2 Was contacted on a few occasions                      3 Was contacted several times and was expected to act before the next working day                      4 Was contacted several times and was not expected to act before the next working day                      9 Not applicable (not included in filter)                      Blank No answer / Don't know</p>	WSTATOR = 1,2
216-217	RECHOURS	<p style="text-align: center;"><b>SUB-MODULE 2: METHODS AT WORK</b></p> <p style="text-align: center;"><b>Flexibility for taking whole days off for care</b></p> <p><i>Method of recording the presence or working hours in the main job</i></p> <p>01 Presence and hours are not recorded                      02 Presence recorded manually by one-self                      03 Presence recorded manually by supervisor/colleague                      04 Presence recorded automatically (clocking system, at log-in)                      05 Presence recorded with another method                      06 Hours recorded manually by one-self                      07 Hours recorded manually by supervisor/colleague                      08 Hours recorded automatically (clocking system, at log-in)                      09 Hours recorded with another method                      99 Not applicable (not included in filter)                      Blank No answer / Don't know</p>	STAPRO = 3
218	PRESSURE	<p style="text-align: center;"><b>Working under time pressure</b></p> <p><i>Frequency to which the person works under time pressure in the main job</i></p> <p>1 Always                      2 Often                      3 Sometimes                      4 Never                      9 Not applicable (not included in the filter)                      Blank No answer / Don't know</p>	WSTATOR = 1, 2



**Specifications of the 2019 ad hoc module on work organisation and work time arrangements**

Column	Code	Description	Filters/remarks
219-220	JOBAUTON	<p style="text-align: center;"><b>Job autonomy</b></p> <p><i>Possibility to influence order and content of tasks in the main job</i></p> <p>11 Large influence on order and content                      12 Large influence on order and some on content                      13 Large influence on order and little or none on content                      21 Some influence on order and large influence on content                      22 Some influence on order and content                      23 Some influence on order and little or none on content                      31 Large influence on content and little or none on content                      32 Some influence on content and a little or none on order                      33 Little or no influence on order and content                      99 Not applicable (not included in filter)                      Blank No answer / Don't know</p>	WSTATOR = 1, 2
221	PLACEWK	<p style="text-align: center;"><b>SUB-MODULE 3: PLACE OF WORK</b></p> <p style="text-align: center;"><b>Main place of work</b></p> <p><i>Place where activities for main job are mainly carried out</i></p> <p>1 Employer's or own premises                      2 Home                      3 Clients' places                      4 Non-fixed place (vehicle, delivery service etc)                      9 Not applicable (not included in filter)                      Blank No answer / Don't know</p>	WSTATOR = 1, 2
222-224	COMMUTM	<p style="text-align: center;"><b>Commuting time</b></p> <p><i>Time to get from home to work for the main job</i></p> <p>000-240 Minutes                      999 Not applicable (not included in filter)                      Blank No answer / Don't know</p>	PLACEWK < 2
225	OTHERLOC	<p style="text-align: center;"><b>Working on other locations</b></p> <p><i>Works in more than one location for main job</i></p> <p>1 Daily                      2 Not daily but at least every week                      3 Less than every week but at least every month                      4 Less than every month                      9 Not applicable (not included in filter)                      Blank No answer / Don't know</p>	PLACEWK = 1-5

VARIWT : Variable working time  
(Eurostat AHM 2019 Col 211)

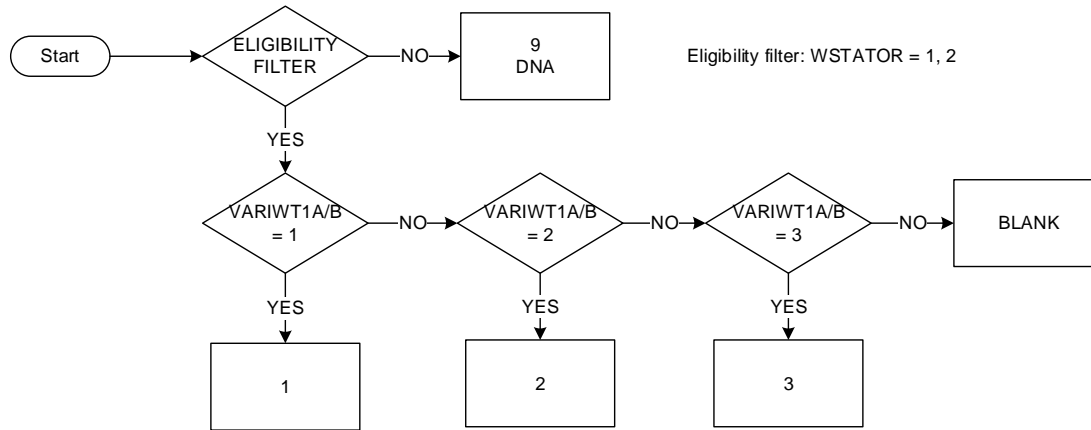

**Key**  
*What determines the start and end of the working time in the main job*  
 1 Worker can fully decide working time  
 2 Worker can decide working time with certain restrictions  
 3 Employer or organisation mainly decides working time  
 9 Not applicable (not included in filter conditions)  
 Blank (-8) Unknown

FREEHOUR : Freedom to take hours off  
(Eurostat AHM 2019 Col 212)

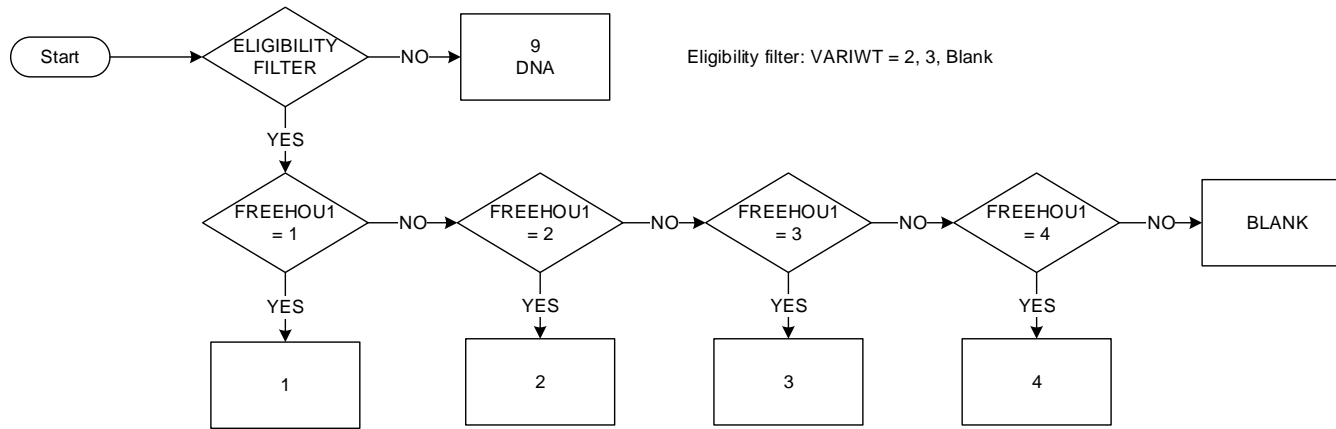

Key  
Possibility to take one or two hours off in the main job for personal or family matters within one working day  
1 Very easy  
2 Quite easy  
3 Quite difficult  
4 Very difficult  
9 Not applicable (not included in filter conditions)  
Blank (-8) Unknown

FREELEAV : Freedom in taking leave  
(Eurostat AHM 2019 Col 213)

Start date: Jan 2019  
End date: Dec 2019

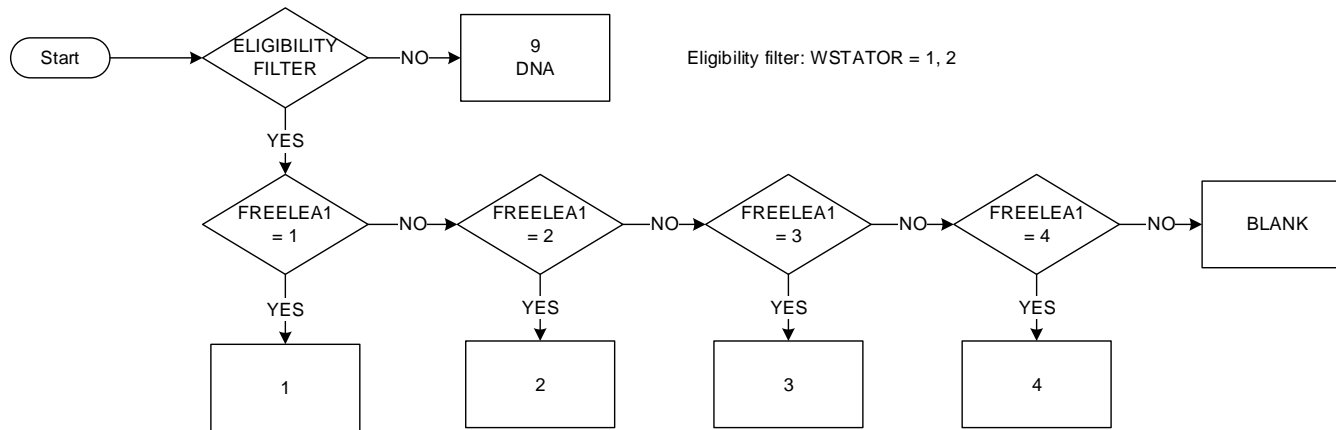

**Key**  
 Possibility to take one or two days off in the main job within three working days  
 1 Very easy  
 2 Quite easy  
 3 Quite difficult  
 4 Very difficult  
 9 Not applicable (not included in filter conditions)  
 Blank (-8) Unknown

FLEXWT : Expected flexibility in working time  
(Eurostat AHM 2019 Col 214)

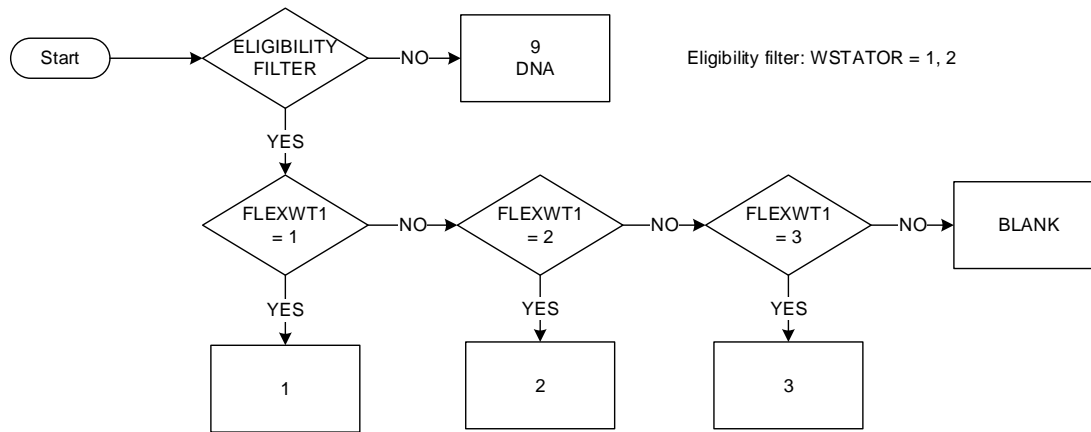

**Key**  
*Frequency with which the worker has to face unforeseen demands for changed working time in the main job*  
 1 At least once a week  
 2 Less than every week but at least once a month  
 3 Less than every month or never  
 9 Not applicable (not included in filter conditions)  
 Blank (-8) Unknown

AVAIFREE : Available for work in free time  
(Eurostat AHM 2019 Col 215)

Start date: Jan 2019  
End date: Dec 2019

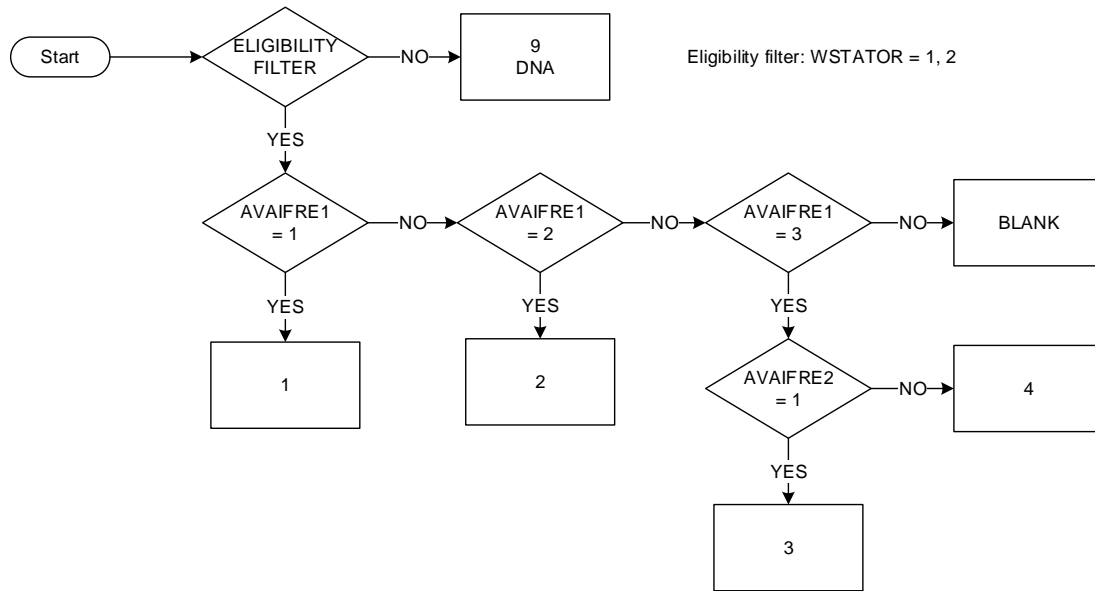

**Key**  
 Worker was contacted during leisure time in the last two months to take action before the next working day for the main job  
 1 Was not contacted in the last two months  
 2 Was contacted on a few occasions  
 3 Was contacted several times and was expected to act before the next working day  
 4 Was contacted several times and was not expected to act before the next working day  
 9 Not applicable (not included in filter conditions)  
 Blank (-8) Unknown

RECHOURS : Recording of presence or working hours  
(Eurostat AHM 2019 Col 216-217 )

Start date: Jan 2019  
End date: Dec 2019

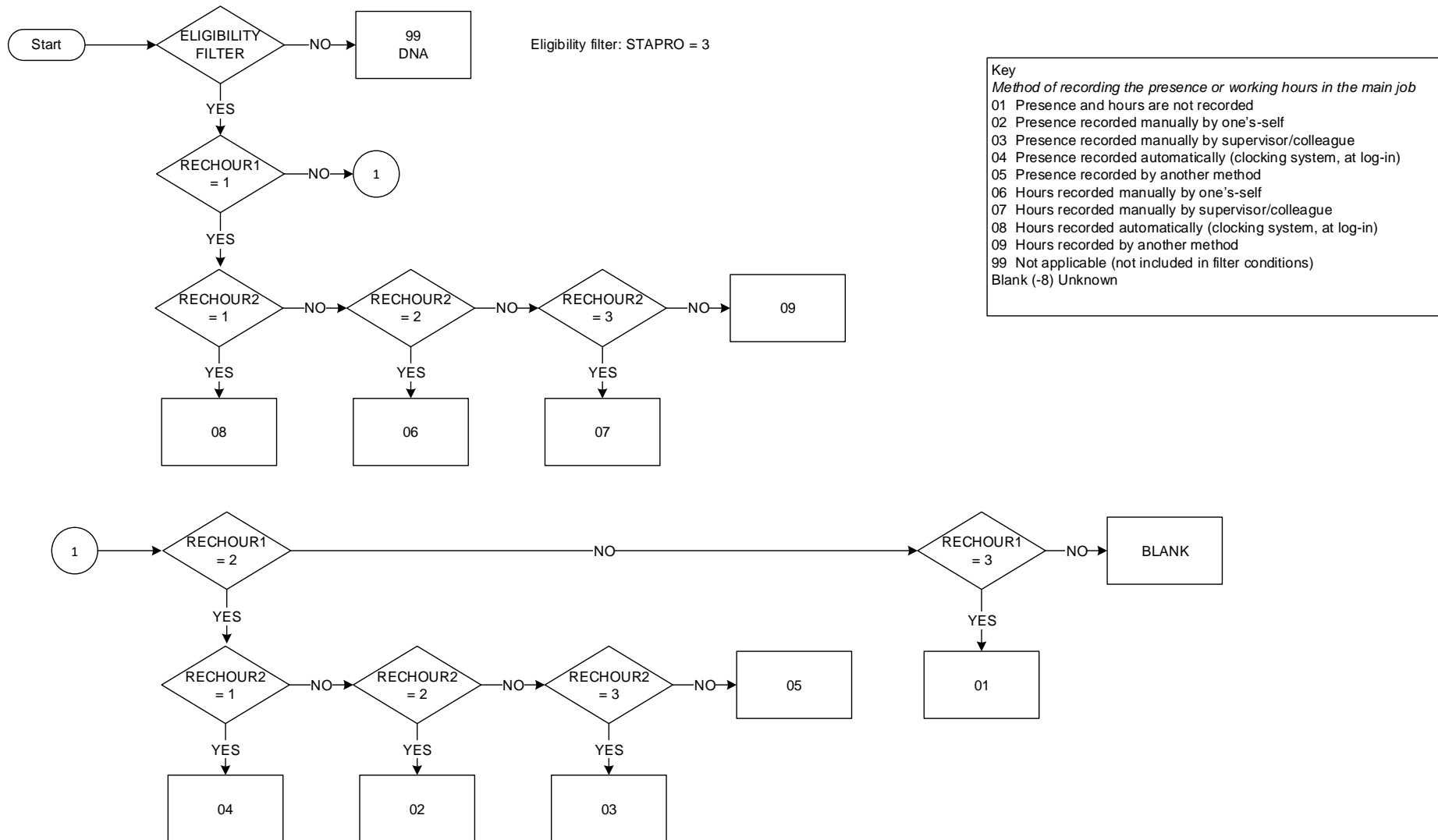

**PRESSURE : Working under time pressure**  
(Eurostat AHM 2019 Col 218)

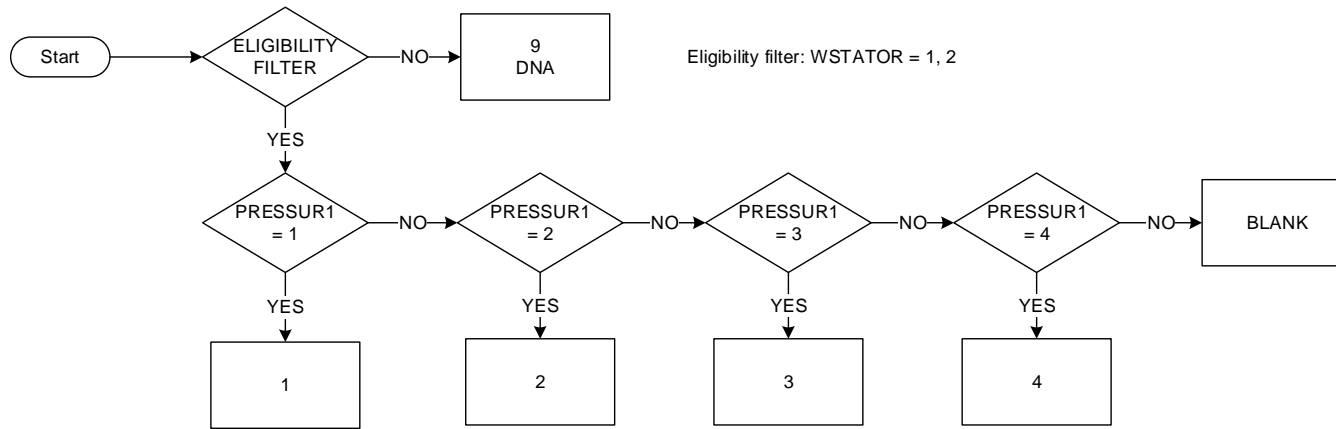

**Key**  
*Frequency with which the person works under time pressure in the main job*  
 1 Always  
 2 Often  
 3 Sometimes  
 4 Never  
 9 Not applicable (not included in filter conditions)  
 Blank (-8) Unknown



JOBAUTON : Job autonomy  
(Eurostat AHM 2019 Col 219-220)

Start date: Jan 2019  
End date: Dec 2019

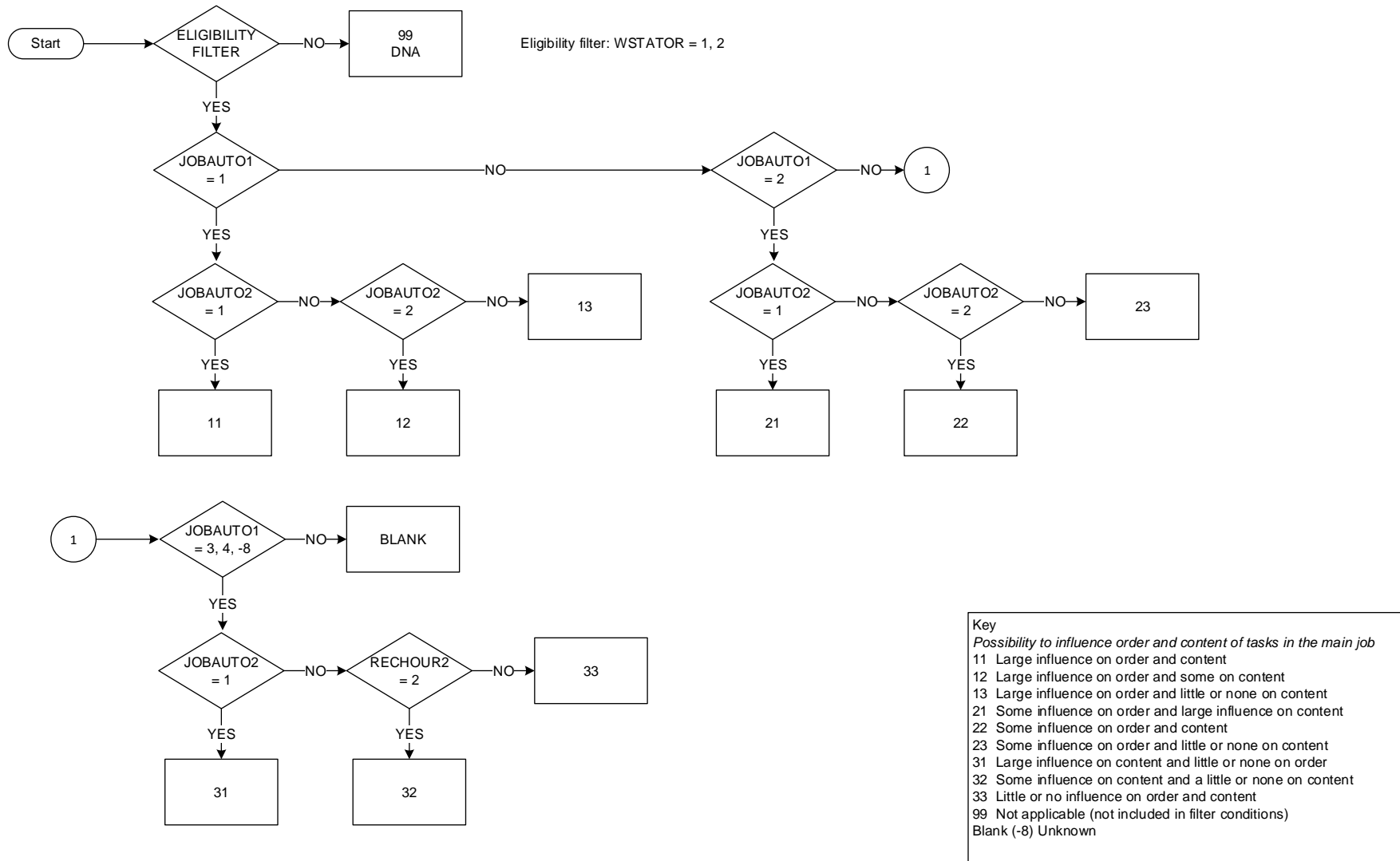

PLACEWK : Main place of work  
(Eurostat AHM 2019 Col 221)

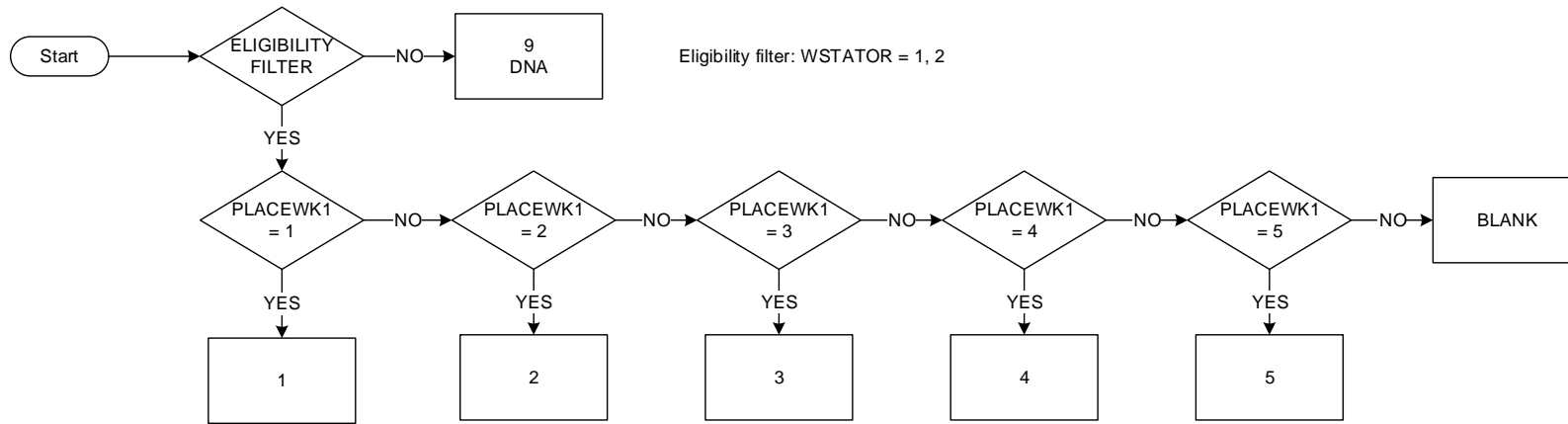

Key  
Place where activities for main job are mainly carried out  
1 Employer's or own premises  
2 Home  
3 Clients' places  
4 Non-fixed place (vehicle, delivery service etc)  
5 Other  
9 Not applicable (not included in filter conditions)  
Blank (-8) Unknown

COMMUTM : Commuting time  
(Eurostat AHM 2019 Col 222-224)

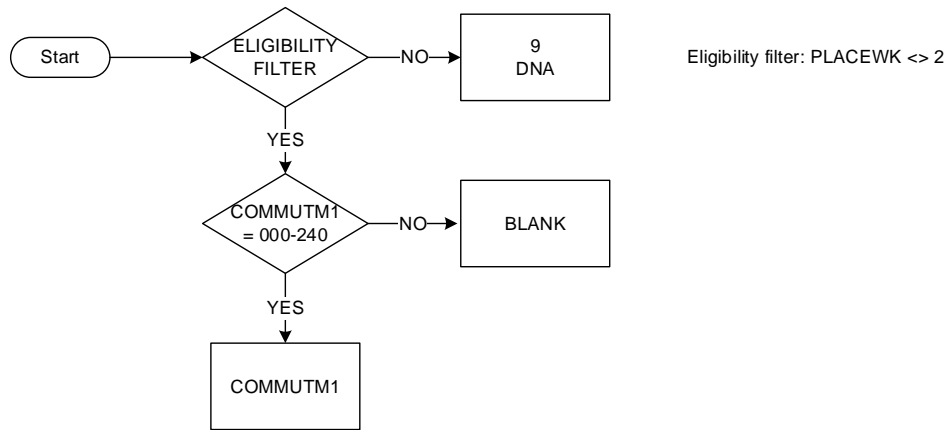

Key  
Time to get from home to work for the main job  
000 – 240 Minutes  
999 Not applicable (not included in filter conditions)  
Blank (-8) Unknown

OTHERLOC : Working at other locations  
(Eurostat AHM 2019 Col 225)

Start date: Jan 2019  
End date: Dec 2019

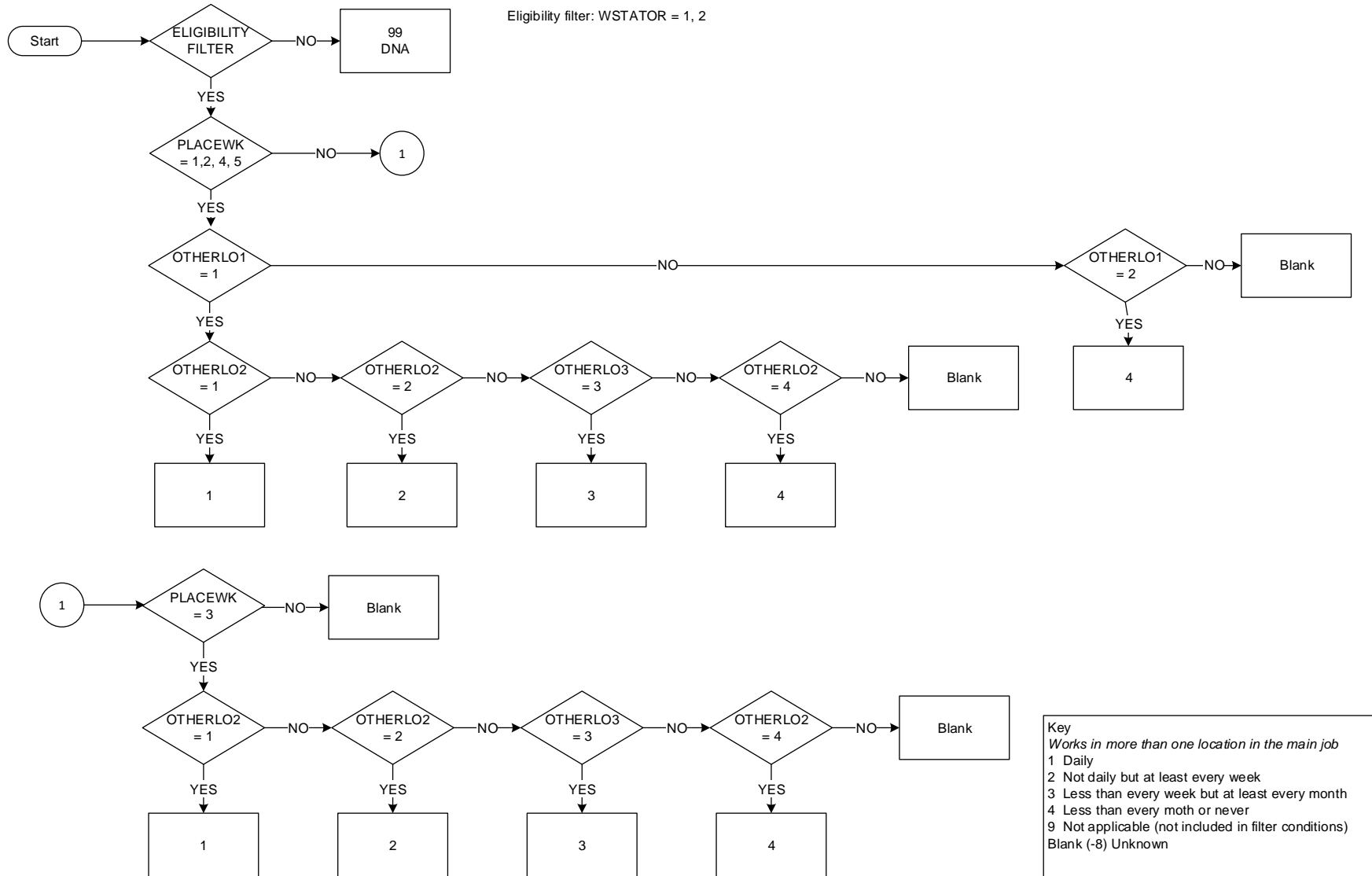

## Variables, model questionnaire and explanatory notes for the AHM 2019

### VARIWT Col 211

*How is determined the start and end of the working time in the main job*

#### **Purpose**

The variable measures if the main job of a person allows to change working times on own behalf. For employees this mainly means the degree of freedom or flexibility as it is defined by an agreed working time arrangement with the employer. Self-employed should in general have a high degree of flexibility but it could be that they have restrictions imposed by clients, legal regulations or opening hours.

#### **Explanatory Notes**

Working time is understood as the working schedule (working days in a week and working hours in a day), and in order to make the variable more concrete, it focuses on the start and end times of the working day.

The variable measures the respondent's situation. It does not aim to capture the general situation at the whole business or organisation in determining the start and end of the working time.

In case of *employees*, the variable intends to capture the way in which working time is officially set. It is set by the employer or by the employee or to varying degrees by both. When employees exceptionally vary their working times beyond the official agreement, this is not of relevance for this variable. Option 1 should also be chosen when the employee has no agreed working time at all, but only objectives or responsibilities (e.g. for directors, high-level experts).

Shift-workers, including police forces or nurses, can chose the most appropriate answer, depending on how their shifts are defined (fully determined or can be adapted). Teachers, where some working hours cannot be changed (lessons) but another part (preparation/follow-up) can be organised absolutely freely most likely, should choose the middle category (2). Persons with annual working time accounts should rather choose category (1).

One would expect a high degree of flexibility in case of *self-employed* and family workers. However, they should choose the most appropriate answer. If they think that clients, governmental legislation or authorities are the ones who mainly determine their working time, then the answering categories identifying restrictions could be more appropriate. Self-employed who have very few or no possibilities to determine their working times because of e. g. clients' demands or legal regulations or a combination of several factors should choose category 3. The working time determined by clients is more frequent for self-employed, but it is not limited to this case. Deadlines can influence working time even though within those limits working times can be freely set.

The arrangement of *flexitime* is a special case of the situation where the worker can decide working time together with the employer (so, with certain restrictions).

## **FREEHOUR Col 212**

*Possibility to take one or two hours off in the main job for personal or family matters within one working day*

### **Purpose**

The variable measures the at short notice possibility to take hours off to accommodate to personal or family matters. It tries to assess if persons in employment with not fully flexible working time regimes (measured by VARIWT) potentially have additional flexibility to reconcile work and family life.

The variable measures the respondent's situation. It does not aim to capture the general situation or rules at the enterprise or organisation in taking hours off. The question measures the respondent's general expectation of the ease or difficulty to take one or two hours off. It does not have to base on personal experiences which will of course influence the expectations accordingly if they exist.

### **Explanatory Notes**

Persons in employment who can freely set their working times can be assumed to take easily hours off. They are not asked questions but information from VARIWT is used to determine the appropriate code.

Personal or family matters exclude leisure purposes (e.g. playing tennis). Medical appointments, running important errands, participating at family events are included. In general, these are examples of important personal or family matters, without including the dramatic examples of accidents or emergencies for which the worker often has a clear right to leave work.

The time reference of "one working day" is included because also matters that need to be taken care of at short notice should be covered.

It does not matter if the hours taken off have to be compensated or not. Relevant for this variable is only the possibility of taking hours to increase flexibility and facilitate reconciliation with family or personal matters.

If an employment already offers certain flexibility and there is distinction between core and non-core hours, the question relates to the core hours.

Spontaneous answer: impossible is coded under code 4.

## **FREELEAV Col 213**

*Possibility to take in the main job one or two days of leave within three working days*

### **Purpose**

This variable measures working time flexibility as the possibility to spontaneously take days off. It is independent from the motivation or reason for doing so. It is not supposed to measure if persons becoming sick may have problems of staying at home.

The intention is to get the employed persons' perception if the work activity in liaison with colleagues and supervisors allows in principle the respondent to take days at short notice (the time reference of "three working days" is used to cover the concept of "at short notice").

It is not to check if the leave, as workers' right, exists and is in principle in place even though it of course has an influence.

## **Explanatory notes**

Days off are understood as holidays. Days off taken for illness are excluded.

The time reference of "three working day" is used to cover the concept of "at short notice".

Long (or planned) leaves are excluded. For the purpose of the variable, it is assumed that the 1-2 days of leave are outside the planned leave (in the cases when part of the annual leave is agreed together with colleagues/superiors), and not during the period in which the business is closed, or production stopped.

The respondent is invited to consider the usual situation. If periods when leave cannot be taken (because of specific rhythms and deadlines) occur regularly or make up a substantive part of the job the answer will reflect this. On the other hand, if such periods are exceptional, then they should not influence the answer to this question.

The question measures the general expectation of the ease or difficulty to take one or two days of leave. In the case when experiences exist, it will of course influence the expectation accordingly.

Spontaneous answer: impossible is coded under code 4.

## **FLEXWT Col 214**

*Frequency to which the worker has to face unforeseen demands for changed working time in the main job*

### **Purpose**

This variable concerns the flexibility the respondent has to show in order to fulfil the work tasks. The variable does not measure expectations or a perceived pressure at the workplace but concrete behaviour how often the respondent usually has to adapt his working times to fulfil the work.

This can be the consequence of a self-perceived necessity because of the volume of work or tight or changed deadlines. While this will be often the situation for self-employed in the case of employees it may also be a consequence of a request from the employer.

If the respondents regularly have to adapt their working schedules it will have a negative impact on the freedom to organise their leisure time or fulfil family responsibilities. It thus stands in contrast to the variables FREEHOUR and FREELEAV which measure flexibility in favour of the provider of work or goods.

## **Explanatory notes**

Changes made to the working time means mainly starting earlier or later or by working longer. Overtime can be the consequence. For shift worker that would mean that have to come to extra shifts or an agreed shift pattern has to be changed (e.g. changing from the morning to the late shift). For persons with fully flexible working times this would mean that they have to change their working times e. g. at short notice or that they have to adapt working times to requirements of supervisors, clients or tasks.

It plays no role if eventual overtime is paid or unpaid.

## **AVAIFREE Col 215**

*Worker was contacted during leisure time in the last two months to take action before the next working day for the main job*

### **Purpose**

This variable measures the general availability and immediate reaction on requests by employers and clients. It is going further than FLEXWT because it focusses on concrete requests coming from the employer or clients and a quick reaction is required that directly interferes with leisure time. Again the variable does not relate to expectations but the concrete occurrence of situations when the respondent was contacted and had to react.

More explicitly than FLEXWT this variable assesses the impact a job can have on the free time of a person and in how far there could be a problem for the work-life balance.

### **Explanatory notes**

The persons in employment can be contacted by their boss, colleagues, business partners, etc. as well as by clients. The contact can be by phone (or mobile devices), at the private or business e-mail address or in person. E-mails sent to the business e-mail address outside office hours if the worker is normally not expected to read these e-mails before the next working day, are not considered a contact. The checking of e-mails as such is not counted as a contact.

Self-employed and most family workers should choose the most appropriate answer for their leisure time. For most employees, 'leisure time' means being contacted in between working days after their regular work hours and before the start of the next working day.

A person is expected to take action before the next working day means that he/she is expected (by employer, business, colleagues, clients) take action quickly following the contact, the action cannot wait until the next working day. In contrast, reacting to the contacting or receiving the information alone (reading e-mail, answering a call) is not regarded as taking action. Giving a productive input like providing information or making decisions on the phone or by e-mail is.

Respondents who are on "standby" (i.e. who receive some money to be available to go to work in case of emergency) should consider this period as leisure time in question Avaifree\_Q1.

In question Avaifree\_Q2 it is sufficient to have been expected to take action before the next working day once in order to answer 'yes'.

The reason to apply a reference period of two months is that we try to measure the occurrence of concrete events and this requires a reference period. The period of two months is chosen to avoid problems with holiday periods and to keep the period short to limit recall problems.



## RECHOURS Col 216-217

*Method of recording the presence or working hours in the main job*

### **Purpose**

This variable intends mainly to assess the degree of autonomy and trust that are given to the employee. While no recording or manual self-recording would stand for a high level, an automatic recording or even under control of a supervisor are clearly more restrictive. The recording of presence can be seen as less strict than an exact recording of the hours worked. On the other hand the recording can be a protection of the employee against working frequently more than contractually agreed or a constant availability outside working hours.

Even though this variable gives an idea of applied recording modes its purpose is not to find out exact frequencies of the used systems or technical solutions to record working hours.

### **Explanatory notes**

*Automatic recording* means that the working hours or presence is recorded by an automatized system when the employee enters the building, logs into a computer or device, or starts a machine or vehicle. A computer registering log-in could also be at home when used for teleworking. Clocking systems are included here no matter if they work with punch cards or electronically. This consequently means that the record depends directly on the presence of the employee on the employer's premises or on the operation of a computer or machine. Also a driver whose working time is measured through the operation of a truck would be counted here.

*Informal recording* is not included. This means when presence is captured as side-effect e. g. by an electronic system granting access to a building. Also for teachers or sales personnel it is obvious when they are present or do not arrive in time. But if none of the above is actually used for time balances or presence records, it should not be counted as recording.

The frequency of the recording (daily, weekly or monthly) is not relevant for the purpose of the variable. The same applies to the period covered which could be hours worked in a day, week or month.

When respondents have different kinds of recording in their main job, they should mention the one that covers most of the working time. For example, an employed craftsman could have his working hours at the workshop supervised by the secretary but notes the working hours by himself, when he is at clients' places. If he mainly works at client's places he should choose own recording. This also applies when only specific working hours are recorded (e.g. overtime or hours taken off) but the majority of working hours are not recorded: then code 01 (presence and hours are not recorded) or codes 02 to 05 (only presence is recorded) should be chosen.

*Manual own recording* is independent from the used technique. It may be own notes on paper, in prepared paper forms, into own or standardised computer tables or into an electronic system. Decisive is that the employee enters the times to own discretion.

If own time recording has to be validated by a supervisor distinguishing between answer 2 and 3 in Rechours\_Q2 depends on the degree to which the supervisor actually monitors and corrects the employees recordings. If time sheets are normally validated without corrections or only when the employee has made an obvious mistake, answer 2 in Rechours\_Q2 should be chosen. If corrections frequently occur or would very likely occur when real and indicated times do not coincide, answer 3 in Rechours\_Q2 should be chosen. If the working hours are directly noted by a colleague or supervisor also answer 3 in Rechours\_Q2 should be chosen. This also applies when a presence sheet had to be signed or the working hours sheet had to be filled in the presence of a colleague.

This variable also fully applies to people doing home- or telework. In theory all forms of hours or presence recording are possible.

The answer categories for both questions should be presented to the respondent before answering, so that he/she knows that there is interest in recording of hours or presence and in the kind of recording methods.

## **PRESSURE Col 218**

*Frequency to which the person works under time pressure in the main job*

### **Purpose**

This question assesses how common it is for the respondent in the main job to work under time pressure. That means that the time the respondent has to accomplish the work tasks is not sufficient and he/she either has to speed up work and eventually to extend working times. This variable can be interpreted in relation to FLEXWT where the work necessitates a change of working times here it effects an increased work pace and/or feelings of discomfort and stress.

This variable is subjective. Even though objective conditions influence the time pressure someone is exposed to, it also depends on individual capacities and the subjective interpretation of the situation.

### **Explanatory Notes**

Respondents should know the four possible categories before answering. They should be read out or shown when the question is asked.

The perception of the respondent should be recorded. He/She should choose the modality that they find most appropriate. The question measures the share of the working time the respondents feels working under time pressure. Even though it gives an objective cue to the understanding of time pressure the answer will be a combination of general ideas of a manageable workload and the respondents capacities to deal with it.

## **JOBAUTON Col 219-220**

*Possibility to influence order and content of tasks in the main job*

### **Purpose**

This variable measures the autonomy of the respondent in the main job, meaning in how far he/she can influence the way work is carried out or that it is less predefined by the organisation and more left to the employee. A high job autonomy is also often seen as an indicator for a higher job quality and related to a higher job satisfaction.

It covers the two dimensions of influence on (1) the order and (2) the content of the tasks. The variable measures the extent to which the respondent thinks he/she can influence them. It thus does not measure the actual influence but the subjective perception of it.

## **Explanatory notes**

All categories of the scale should be read out before the respondent answers the question.

The subjective perception of the respondent should be recorded and she/he should choose modality found most appropriate. The judgement should be based on the personal experience.

Influencing the content of tasks means that respondents have a certain freedom to decide on how to fulfil their tasks: This means the approaches, methods, tools or used information sources. Respondents may also have freedom to decide about the scope or exact characteristics of the output.

## **PLACEWK Col 221**

*Place where activities for main job are mainly carried out*

### **Purpose**

The variable determines the place where the respondent in his/her main job mainly works. Relevant is the professional context in which work is done and not the physical location as such (e. g. if it is in an office building, outside, etc.). Work can be done in a professional environment set up by the employer or by the respondent in case of a self-employment. Work can be done at home in a private context. In other cases work is performed at the clients' places. Here, a big variety is possible, from working in clients' private places to staying in the company of the client or from a job accomplished in one hour to an assignment lasting several weeks. People who work in a vehicle, for delivery services and alike have even a less stable work environment.

### **Explanatory notes**

The main place of work is the one where the person spends most of the working time, or works most frequently. If the work is equally split between two places it is up to the respondent to choose the main one among the two. It only refers to the main job.

Premises refer to any building or site that is owned or rented by the employer or self-employed and especially set up for performing the work or service. These can be office buildings, hospitals, shops, schools, farms, company sites, a flat rented for the purpose of having an office their etc. Also premises that are rented occasionally, like class rooms by private teachers or sports grounds by sport teachers would be counted as 'own premises'.

For self-employed, e. g. in artistic or professional activities, who work wholly or partly at home, often in a part of their living accommodation set aside for the purpose should be counted as working from home. However, if the place of work comprises a separate unit (for example, a doctor's surgery or tax consultant's practice) which is adjacent to the person's home but contains a separate entrance, then work should be considered as performed at the own premise.

Client is a generic term for customers, clientele, users, respondents, patients. A work place can be at a client's home, for example in the case of social workers providing home care. It could also be a consultant working for several days or even weeks at the enterprise of the client. Agents or mobile nursing staff that visit several clients per day are counted here, too. The same applies to craftsmen like electricians or carpenters. If an agent or craftsman works mainly at the own or employer's premises because large parts of the work are done there or administrative work dominates the respective categories 1 or 2 should be chosen.

Persons could also work at the location of a third party. These are e. g. constructions workers who work for an enterprise that the site of the enterprise's client or carers who work at the homes of their companies

clients. They should choose category (3). Miners normally work at the employer's premises even though working below ground is a specific place. Employees working in a café at an airport or in a shop gallery also normally work at the shop rented or owned by their employer.

For mobile sales agents the choice of the appropriate category depends on the relative times they share in a vehicle and with the clients. If they spend more time in a car they should choose (4). The same applies for truck drivers, drivers in public transport. For a salespersons working on mobile stands in public spaces or postmen, mainly delivering mail, the same category applies. If that does not seem appropriate for them they can also choose 'other'. Also agents working on fun or trade fairs should choose 'other'.

## **COMMUTM Col 222-224**

*Time to get from home to work for the main job*

### **Purpose**

The variable measures the time an employed respondent has to invest in addition to his/her regular working times. Together with the possibilities to adapt working times to private needs or the obligation to react to request from work it gives a comprehensive picture of the work balance. It also gives an informative picture of how long employed persons normally commute to get to work, if there are significant differences between people living in more urban or rural areas, etc.

### **Explanatory notes**

Work place is the main place of work as identified by PLACEWK. If PLACEWK is "home" it can be assumed that there is no commuting time.

Usual commuting time refers to the most frequently used mode of transport and normal weather conditions. Exceptional situations like extreme weather conditions or unusual traffic jams are excluded.

In the case of alternating and roughly equal shares between two means of transport (e.g. a car on half of the days and bus on the other days) are used, the respondent is invited to estimate an average of the two times.

The complete time from "door to door" should be indicated. If means of transport are combined all should be considered. E.g. when a person combines walking and using a bus or has to walk to or from a parking site the total time spent on commuting is to be measured.

Detours or time needed for other purposes like bringing children to school, even if they are done daily have to be excluded. If the respondent never travelled directly to the workplace or does not know the usual time, he/she should make an estimation.

Respondents who recently changed their job or temporary agency worker should relate the time to the current place of work.

There may be cases (like for agents) when a person does not work at home but he/she indicates that work starts in the moment when he/she leaves home. In that case the commuting time should be zero minutes. In general, traveling time that is part of the job, like for bus drivers, or driving to clients during working time, is not counted as commuting time.

If the place of work comprises a separate unit (for example, a doctor's surgery or tax consultant's practice) which is adjacent to the person's home but contains a separate entrance, then work should be considered as performed at the own premise and PLACEWK coded 1. In that case the commuting time can also be zero minutes.

When the main place of work as identified by PLACEWK corresponds to several locations (as is likely if PLACEWK is “at clients’ place”), and if travelling time is not part of the job, the location to which the respondents commutes the most often should be considered. If not possible because e. g. the locations are constantly varying, an indication of the average commuting time should be given. This applies e. g. to self-employed who exclusively work at clients' places without going to an office before or home carers.

In the case when the person in employment has a temporary residence (often provided by the employer), commuting time is the time to get from that residence to the place of work.

## **OTHERLOC Col 225**

*Works in more than one location for the main job*

### **Purpose**

This variable measures if the respondent changes his/her main working place and the frequency of such geographical changes. This variable can serve several purposes. At first, it measures the stability of the work place. In general a more stable work place is more convenient and less stressful as the work environment stays the same, commuting and the remaining reconciliation with private life does not have to be re-organised regularly.

For respondents who indicated to work at the companies premises we would like to measure if they really only have this one place of work or sometimes work at alternative places, for instance at home or a different local units of the enterprise. Specific identification of telework is covered by HOMEWK in the core. The main interest in respondents working at client's places is the frequency with which they have to change between clients. So, if they have few major clients with longer lasting assignments or many clients and changes per day. For people with a non-fixed working place it is meaningful because it tries to identify if they have another fixed working place besides their non-fixed one.

### **Explanatory notes**

The variable measures how often the respondent changes the workplace. It can be a change within the same kind of work place as measured by PLACEWK, e. g. between different clients or different sites of the employer. But it can also be a change between the categories of PLACEWK like between the own workshop and clients' places or the office and home.

With the variable the frequency of all changes should be covered. Respondents working at clients' places count all changes: those between clients and those to their e. g. workshop or headquarters. For respondents with no fixed work place the change of the (physical) location can be expected to be very frequent or even a continuous part of the job. Thus, for them the variable rather covers a change of the kind of work place.

If respondents only check occasionally emails from home or answer phone calls they should answer Otherloc\_Q1 with "no". Only work that is also normally done at the workplace or counted as working time should be taken into consideration. If the respondent doubts, the minimum time period spent on work in another place should be one hour. In the case of a teacher, if he/she prepares the school lessons and/or corrects the tests at home, he/she can answer Otherloc\_Q1 with "yes".

Respondents who mainly work at clients' places are directly asked with Otherloc\_Q2 'how often they change their work location'. Here, change can be expected as being normal. For the others there is an

introductory question (Q1) if they also work at a different place than the one they already had indicated. This question is also necessary for persons with a non-fixed work place because asking Q2 directly would seem awkward. They should answer 'yes' if they change the kind of workplace. For instance truck drivers who have to work at their headquarters for some time, do logistical planning at an office or return to a depot for maintenance. Going to a distribution hub just to load goods would in contrast not count.

Occasional business trips are excluded. If they make up a substantial part of the regular work (more than 50%) this should already be indicated in PLACEWK because the respondent then probably often travels to clients or could be understood as having no fixed place. If the respondent frequently changes between local units of the employer, this should be indicated as change. In contrast, changes of the location at the premises are excluded like errands or going to meetings. Similarly, training activities at other locations are excluded. If the situation of business trips is variable over time the respondent should relate to the last two months. The variable does also not cover a recent move of the office.

**Specifications of the 2018 ad hoc module on reconciliation between work and family life**

Column	Code	Description	Filters/remarks	
211	CARERES	<b>Sub-module 1: Care Responsibilities</b>		
		<b>Existence of care responsibilities</b>	AGE = 18 - 64	
		<i>Caring regularly for own or partner's children (&lt;15 years) of for incapacitated relatives (15 years or older)</i>		
		1	No care responsibilities	
		2	Only for own children in household	
		3	Only for own children outside the household	
		4	For own children in- and outside the household	
		5	Only for incapacitated relatives	
		6	For own children in the household and incapacitated relatives	
		7	For own children outside the household and incapacitated relatives	
8	For own children in- and outside the household and incapacitated relatives			
9	Not applicable (not included in the filter			
Blank	No answer / Don't know			
212	CHCARUSE	<b>Use of childcare services</b>	CARERES = 2-4, 6-8	
		<i>Use of professional childcare services for some or all children</i>		
		1	No	
		2	Yes, for some children	
		3	Yes, for all children	
		9	Not applicable (not included in filter)	
Blank	No answer / Don't know			
213/214	REASSE	<b>Factors for not using childcare services</b>	CHCARUSE = 1,2	
		<i>Main reason for not using (more) childcare services for own or partner's children</i>		
		01	No service accessible/vacant	
		02	Costs	
		03	Quality/kind of service	
		04	Other service related obstacle	
		05	Care is arranged alone/with partner	
		06	Care is arranged including further informal support	
		07	Used professional services (for some but not for all children) are sufficient	
		08	Children take care of themselves	
09	Not applicable (not included in filter)			
Blank	No answer / Don't know			

**Specifications of the 2018 ad hoc module on reconciliation between work and family life**

Column	Code	Description	Filters/remarks
215	CHCAREFF	<p><b>Effect of childcare responsibilities on employment</b></p> <p><i>Main way employed persons adapted their work to facilitate childcare responsibilities</i></p> <p>1 Any change to increase income                      2 Less working hours                      3 Less demanding tasks in job                      4 Changed job or employer to facilitate reconciliation                      5 Currently on a family leave                      6 Other                      9 Not applicable (not included in the filter)                      Blank No answer / Don't know</p> <p><b>Sub-module 2: Flexibility of work arrangements</b></p>	CARERES = 2-4, 6-8 and WSTATOR = 1,2
216	POSTEND	<p><b>Working time flexibility for care</b></p> <p><i>Possible to vary start and/or end of working day in main job to facilitate care responsibilities</i></p> <p>1 Generally possible                      2 Rarely possible                      3 Not possible                      9 Not applicable (not included in filter)                      Blank No answer / Don't know</p>	STAPRO = 3 and CARERES = 2-8
217	POSORGWT	<p><b>Flexibility for taking whole days off for care</b></p> <p><i>Possible to organise working time in order to take whole days off in main job to facilitate care responsibilities</i></p> <p>1 Generally possible                      2 Rarely possible                      3 Not possible                      9 Not applicable (not included in filter)                      Blank No answer / Don't know</p>	STAPRO = 3 and CARERES = 2-8
218	WORKOBS	<p><b>Main obstacle at work for reconciliation</b></p> <p><i>Characteristic of main job making reconciliation most difficult</i></p> <p>1 No obstacle                      2 Long working hours                      3 Unpredictable or difficult work schedules                      4 Long commute                      5 Demanding or exhausting job                      6 Lack of support from employers and colleagues                      7 Other obstacles                      9 Not applicable (not included in filter)                      Blank No answer / Don't know</p>	WSTATOR = 1, 2 and CARERES = 2-8



Column	Code	Description	Filters/remarks
219	STOPWORK	<p><b>Sub-module 3: Career breaks and parental leave</b></p> <p><b>Career break for children</b></p> <p><i>Not worked for at least one month in his/her employment history to take care for own children</i></p> <p>1 Yes                      2 Never worked, for childcare reasons                      3 No (but was/is employed and has children)                      4 Never worked, for other reason                      5 Never had children                      9 Not applicable (not included in the filter                      Blank No answer / Don't know</p>	AGE = 18-64
220	STOPLENG	<p><b>Complete length of career breaks for childcare</b></p> <p><i>Sum of duration of all work interruptions of at least one month</i></p> <p>1 Up to 6 months                      2 More than 6 months up to 1 year                      3 More than 1 year up to 2 years                      4 More than 2 years up to 3 years                      5 More than 3 years up to 5 years                      6 More than 5 years                      9 Not applicable (not included in filter)                      Blank No answer / Don't know</p>	STOPWORK = 1
221	PARLEAV	<p><b>Use of parental leave</b></p> <p><i>Use of parental leave and/or maternity/paternity as part of work interruption for childcare</i></p> <p>1 Only used parental leave                      2 Combination of family leaves                      3 Only maternity/paternity used                      4 No family leave used                      9 Not applicable (not included in filter)                      Blank No answer / Don't know</p>	STOPWORK = 1
222	DEREDSTP	<p><b>Career break for incapacitated relatives</b></p> <p><i>Not worked or has reduced working time for at least one month in employment history to take care of incapacitated relatives (&gt;15 years)</i></p> <p>1 Work interruption                      2 Only reduced working time                      3 No interruption or reduction                      4 Never had to care for incapacitated relatives                      9 Not applicable (not included in filter)                      Blank No answer / Don't know</p>	AGE = 18-64 and (EXISTPR = 1 or WSTATOR = 1, 2)

CARERES\_DV : Existence of care responsibilities  
(Eurostat AHM 2018 Col 211)

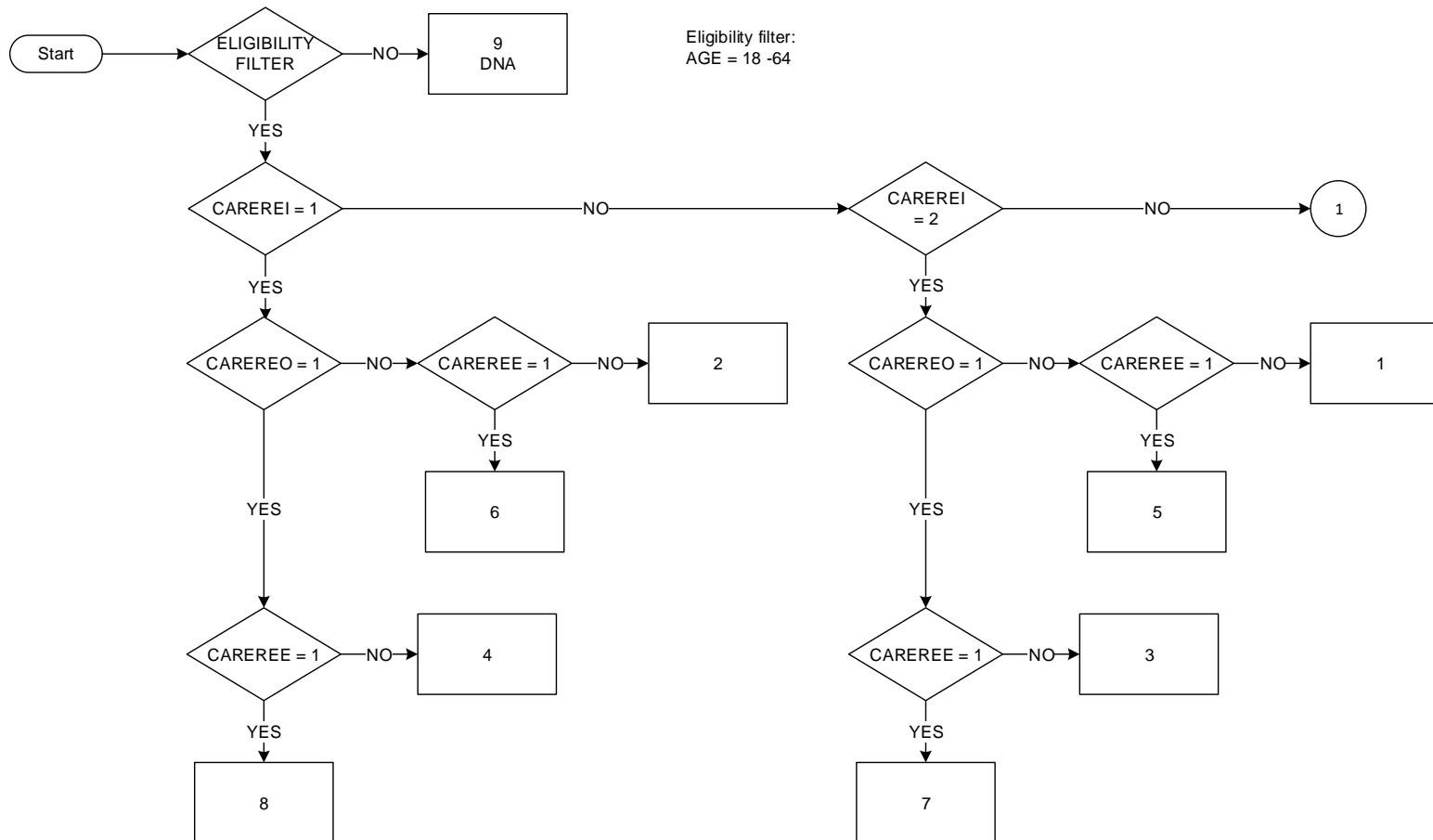

CARERES\_DV : Existence of care responsibilities  
(Eurostat AHM 2018 Col 211)

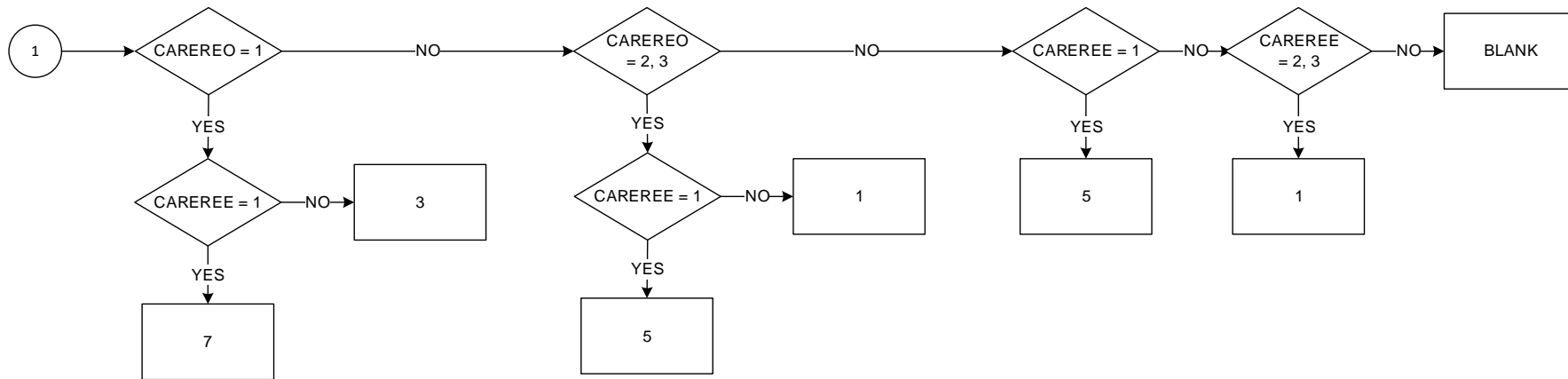

Key  
 Caring regularly for own or partner's children (<15 years) or for incapacitated relatives (>=15 years)  
 1 No care responsibilities  
 2 Only for own children in household  
 3 Only for own children outside the household  
 4 For own children in- and outside the household  
 5 Only for incapacitated relatives  
 6 For own children in the household and incapacitated relatives  
 7 For own children outside the household and incapacitated relatives  
 8 For own children in- and outside the household and incapacitated relatives  
 9 Not applicable (not included in filter conditions)  
 Blank (-8) Unknown

CHCARUSE\_DV : Use of childcare services  
(Eurostat AHM 2018 Col 212)

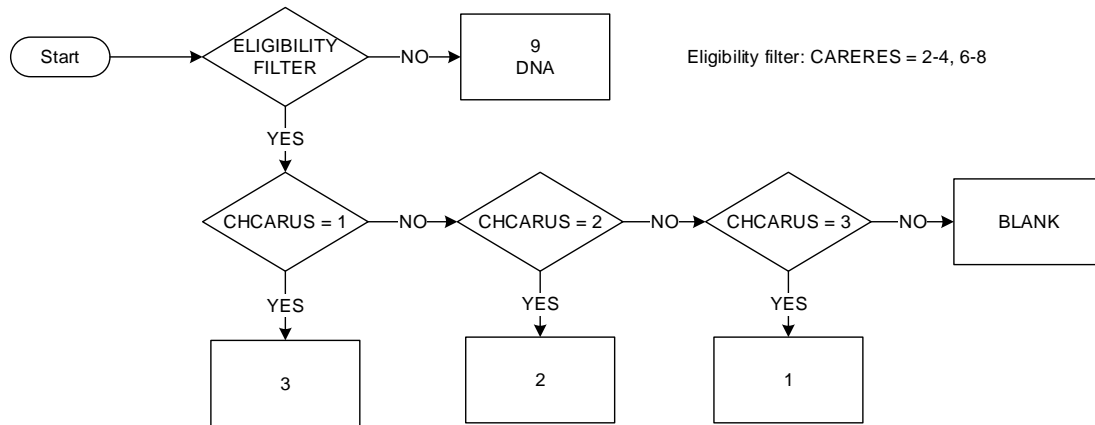

Key	
Use of professional childcare services for some or all children	
1	No
2	Yes, for some children
3	Yes, for all children
9	Not applicable (not included in filter conditions)
Blank (-8)	Unknown

CHCAROBS\_DV : Factors for not using childcare services  
(Eurostat AHM 2018 Col 213/214)

Page 1 of 1  
Start date: Jan 2018  
End date: Dec 2018

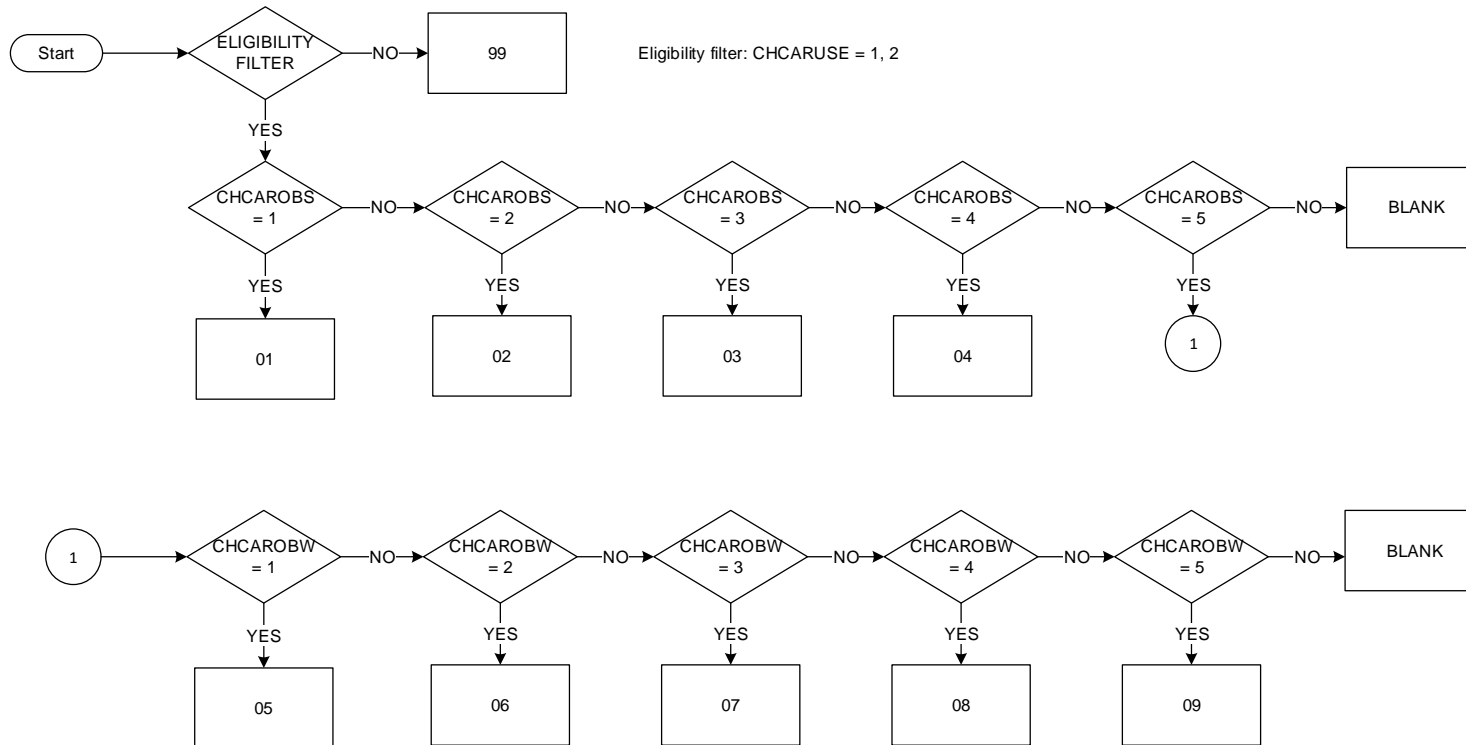

Key	
Main reason for not using (more) childcare services for own or partner's children	
01	No service accessible/vacant
02	Costs
03	Quality/Kind of service
04	Other service related obstacle
05	Care is arranged alone/with partner
06	Care is arranged including further informal support
07	Used professional services (for some but not for all childcare children)
08	Children take care of themselves
09	Other personal reasons
99	Not applicable (not included in filter conditions)
Blank (-8)	Unknown

CHCAREFF\_DV : Effects of childcare responsibilities on employment  
(Eurostat AHM 2018 Col 215)

Start date: Jan 2018  
End date: Dec 2018

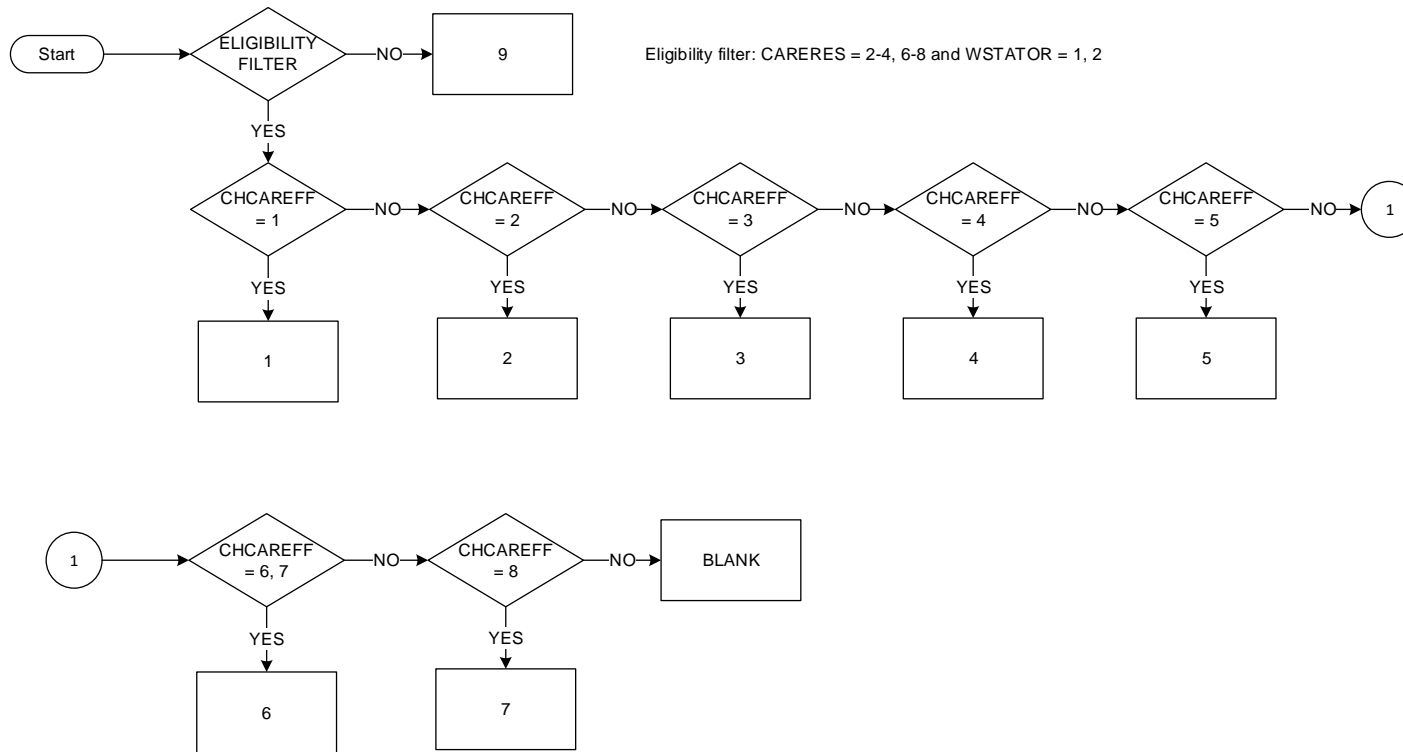

Key  
Main way employed persons adapted their work to facilitate childcare responsibilities  
1 Any change to increase income  
2 Fewer working hours  
3 Less demanding tasks in job  
4 Changed job or employer to facilitate reconciliation  
5 Currently on family leave  
6 Other  
7 No effect  
9 Not applicable (not included in filter conditions)  
Blank (-8) Unknown

POSTTEND\_DV : Working time flexibility for care  
(Eurostat AHM 2018 Col 216)

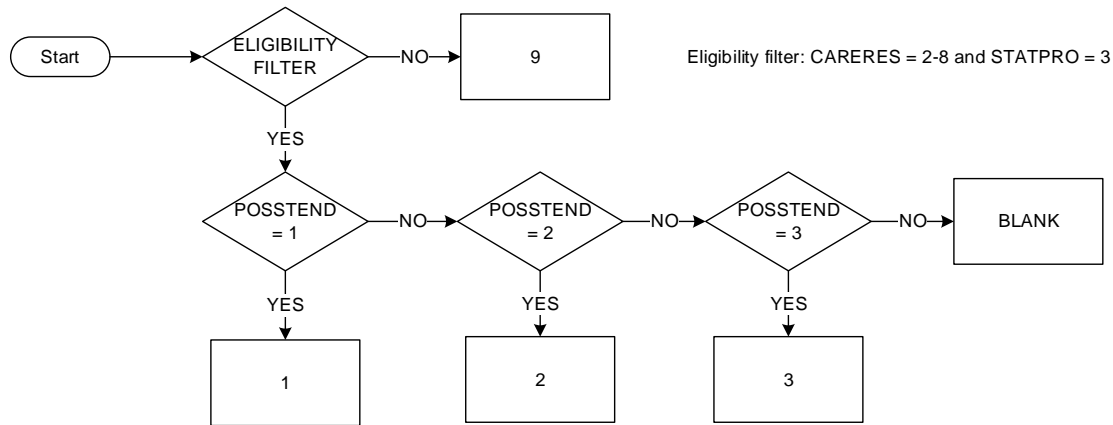

Key  
Possible to vary start and/or end of working day in main job to facilitate care responsibilities  
1 Generally possible  
2 Rarely possible  
3 Not possible  
9 Not applicable (not included in filter conditions)  
Blank (-8) Unknown

POSORGWT\_DV : flexibility for taking whole days off for care  
(Eurostat AHM 2018 Col 217)

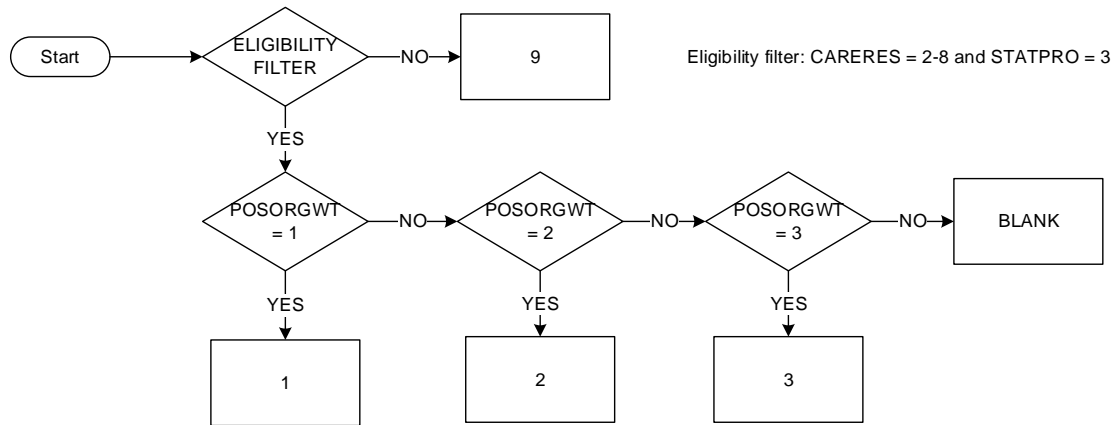

Key  
Possible to organise working time in order to take whole days off in main job to facilitate care responsibilities

- 1 Generally possible
- 2 Rarely possible
- 3 Not possible
- 9 Not applicable (not included in filter conditions)
- Blank (-8) Unknown



WORKOBS\_DV : Main obstacle at work for reconciliation  
(Eurostat AHM 2018 Col 218)

Start date: Jan 2018  
End date: Dec 2018

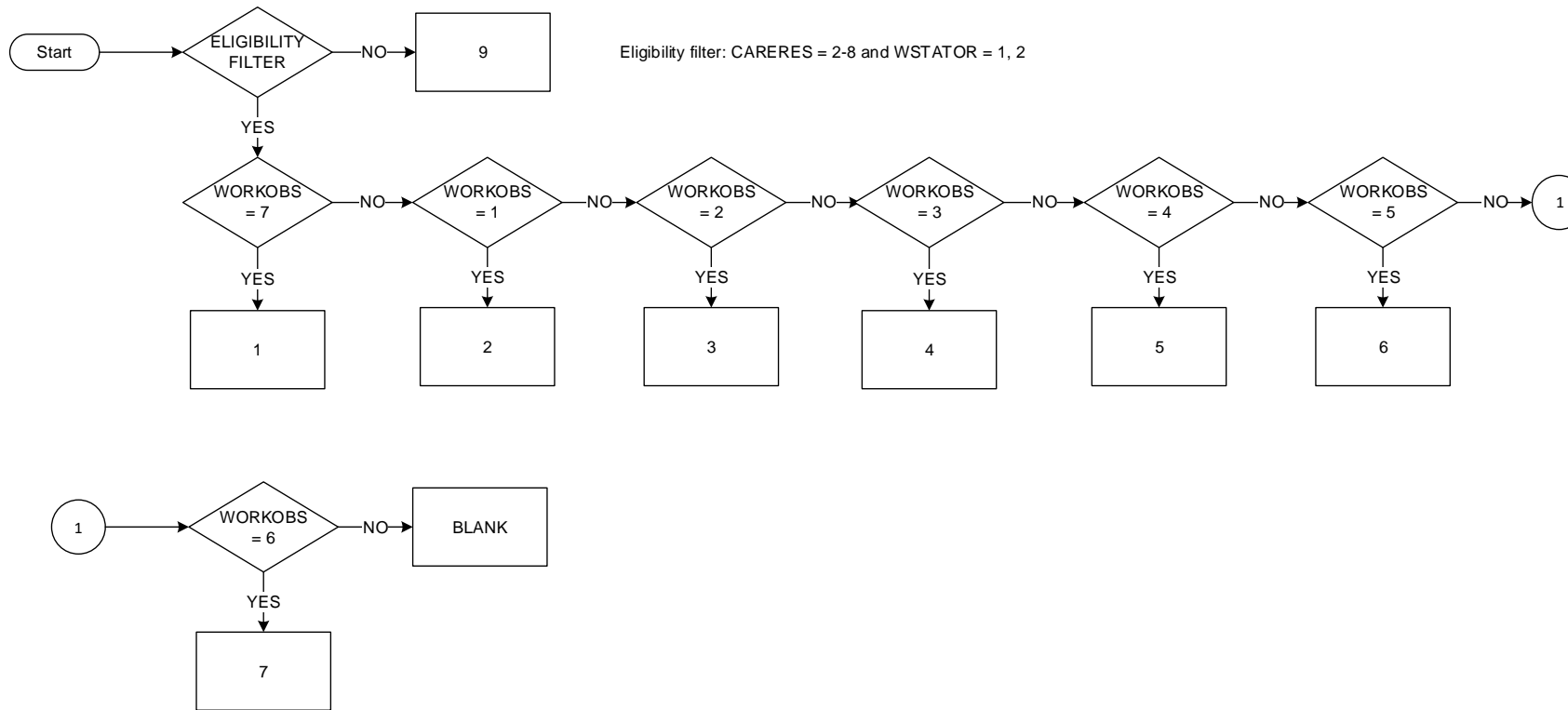

Key	
Characteristic of main job making reconciliation most difficult	
1	No obstacle
2	Long working hours
3	Unpredictable or difficult work schedules
4	Long commute
5	Demanding or exhausting job
6	Lack of support from employers and colleagues
7	Other obstacles
9	Not applicable (not included in filter conditions)
Blank (-8)	Unknown

STOPWORK\_DV : Career break for childcare  
(Eurostat AHM 2018 Col 219)

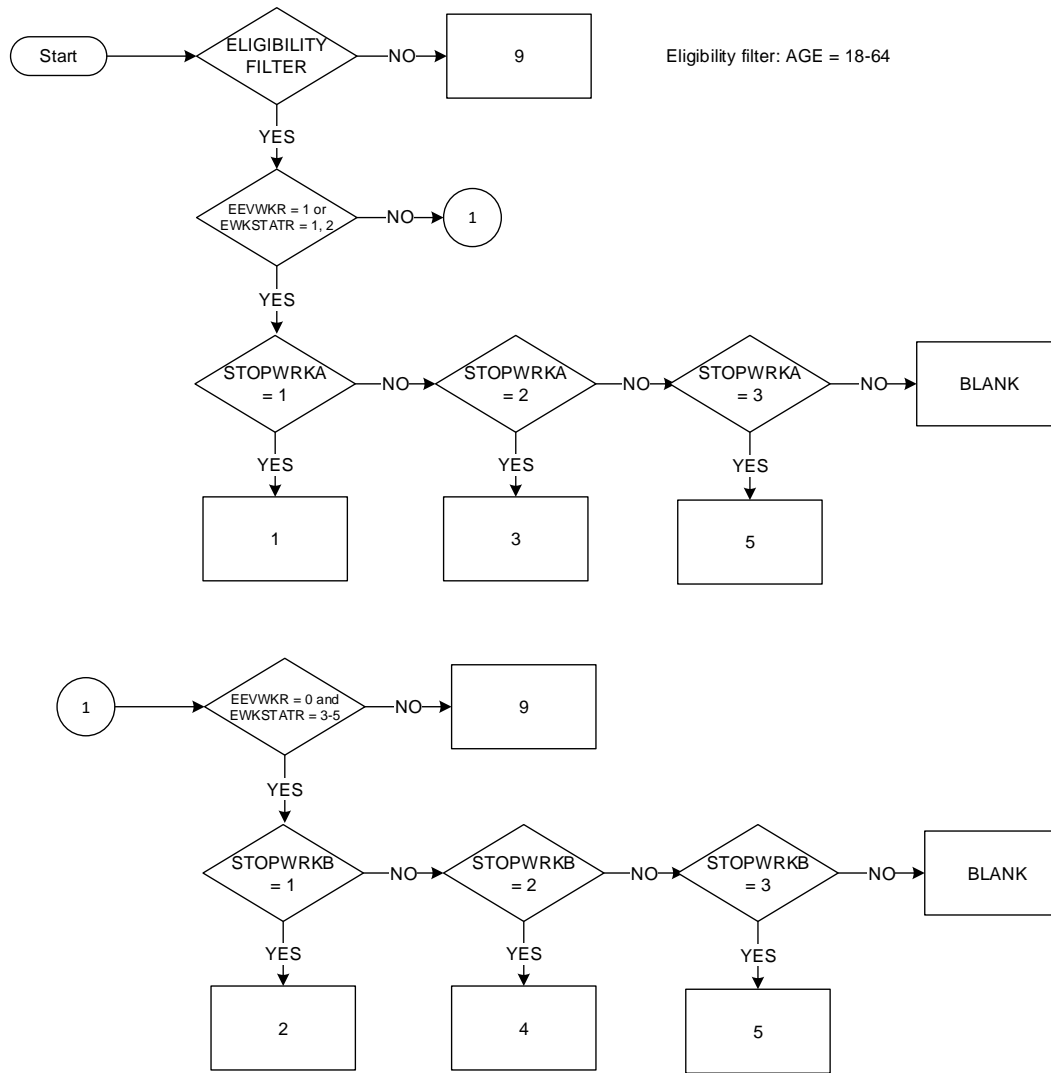

Key

- Not worked for at least one month in his/her employment history to take care of own children
- 1 Yes
- 2 Never worked, for childcare reasons
- 3 No (but was/is employed and has children)
- 4 Never worked, for other reasons
- 5 Never had children
- 9 Not applicable (not included in filter conditions)
- Blank (-8) Unknown

STOPLDNG\_DV : Complete length of career breaks for childcare  
(Eurostat AHM 2018 Col 220)

Start date: Jan 2018  
End date: Dec 2018

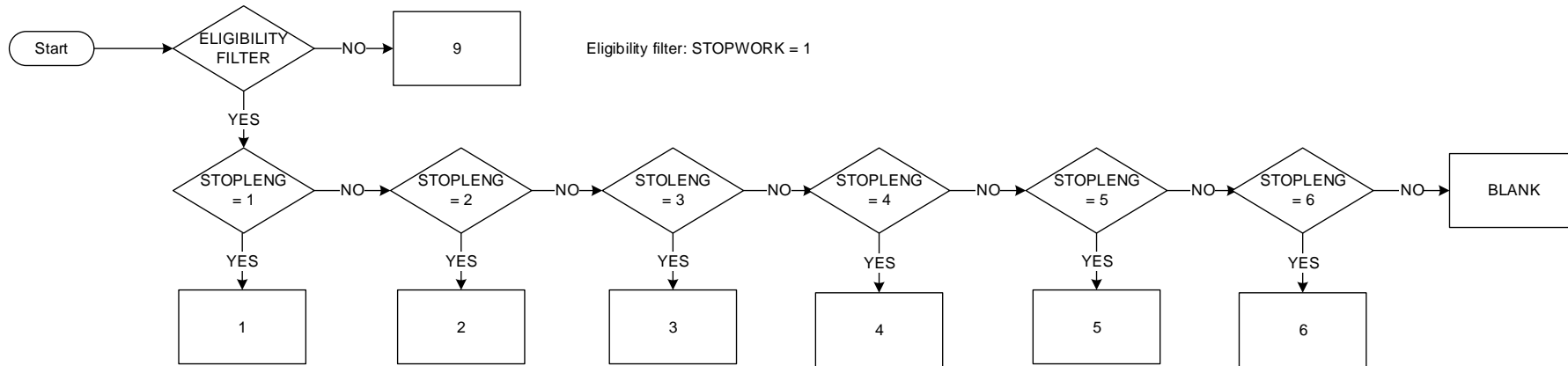

**Key**  
 Sum of duration of all work interruptions of at least one month  
 1 Up to 6 months  
 2 More than 6 months up to 1 year  
 3 More than 1 year up to 2 years  
 4 More than 2 years up to 3 years  
 5 More than 3 years up to 5 years  
 6 More than 5 years  
 9 Not applicable (not included in filter conditions)  
 Blank (-8) Unknown

PARLEAV\_DV : Use of parental leave  
(Eurostat AHM 2018 Col 221)

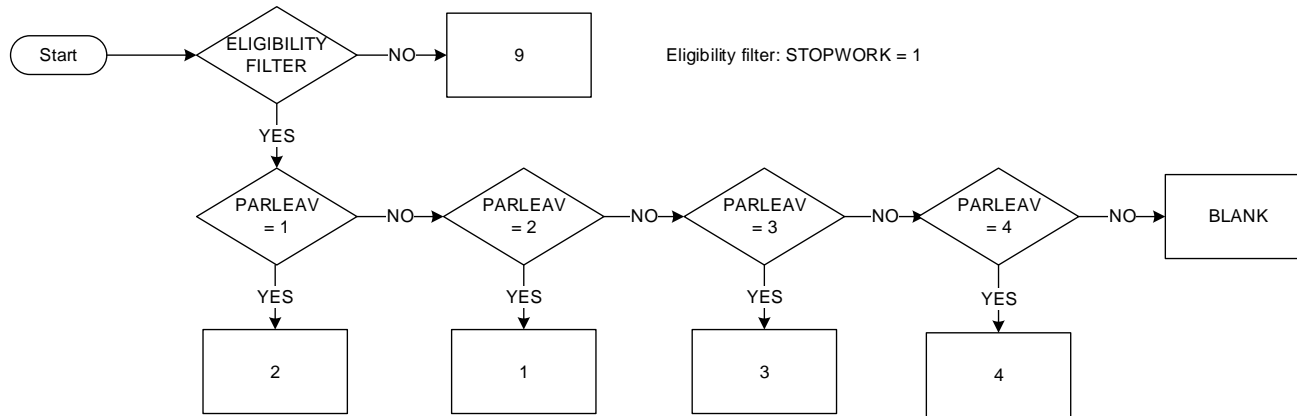

**Key**  
 Use of parental leave and/or maternity/paternity as part of work interruption for childcare  
 1 Used only parental leave  
 2 Combination of family leave  
 3 Only maternity/paternity used  
 4 No family leave used  
 9 Not applicable (not included in filter conditions)  
 Blank (-8) Unknown

DEREDSTP\_DV : Career break for incapacitated relatives  
(Eurostat AHM 2018 Col 222)

Start date: Jan 2018  
End date: Dec 2018

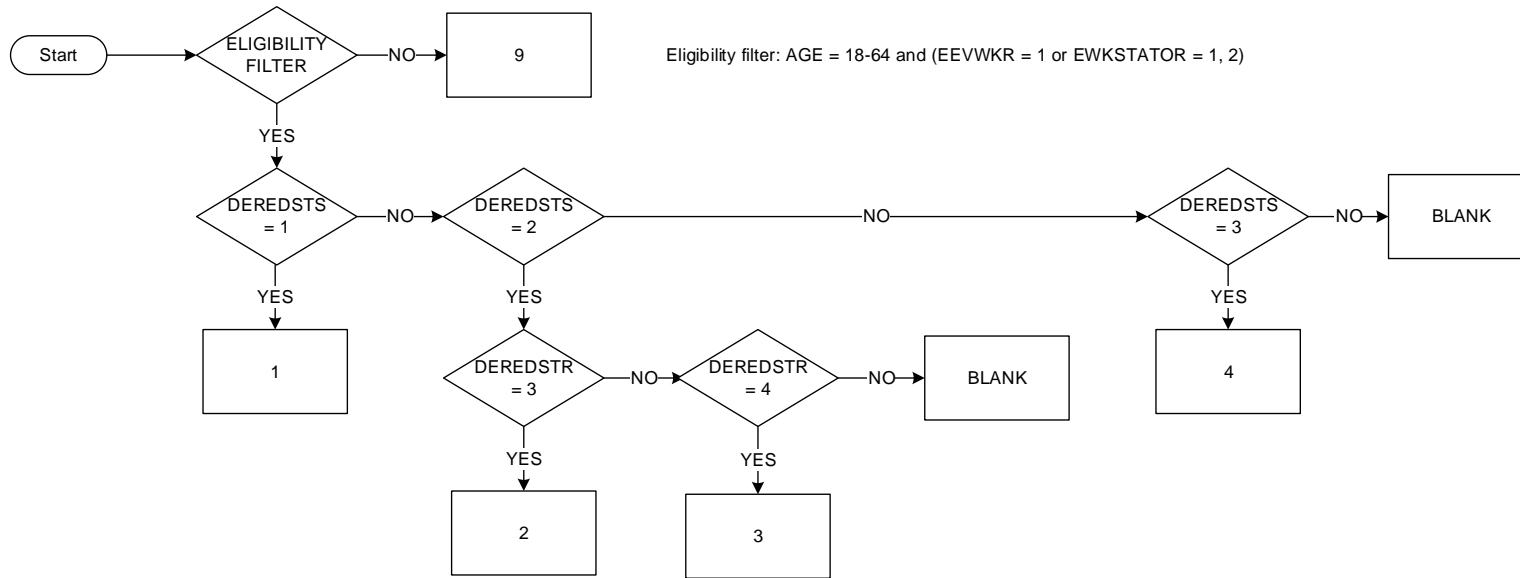

Key  
 Not worked or has reduced working time for at least one month in employment history to take care of incapacitated relatives (>= 15 years)  
 1 Work interruption  
 2 Only reduced working time  
 3 No interruption or reduction  
 4 Never had to care for incapacitated relatives  
 9 Not applicable (not included in filter conditions)  
 Blank (-8) Unknown

## Variables, model questionnaire and explanatory notes for the AHM 2018

### CARERES Col 211

#### *Existence of care responsibilities*

#### **Purpose**

Gaining a comprehensive picture of all existing care responsibilities for own and spouse's or partner's children up to 14 years of age and other incapacitated relatives from the age of 15.

As the module is intended to assess in how far work and care responsibilities limit each other, all existing care responsibilities have to be identified. In contrast to the last ad-hoc module on reconciliation, only care for relatives is covered. Care needs of relatives more likely imply responsibilities to the respondent and thus may impede their labour market participation more than care support for non-relatives (e. g. friends, children of neighbours), that is more provided on a voluntary basis, and only when the circumstances allow. Besides this conceptual refinement for the AHM 2018, this also implies an easier approach for collecting the corresponding information in the interview.

#### **Explanatory Notes**

The variable is split into three questions. Q1 does not need to be asked if the information is already collected in the LFS core. Furthermore, the questions are not to be asked in one sequence to make the flow of the interview more logical to the respondent. In a first step Q1 (if necessary) and Q2 are asked to determine if there are care responsibilities for own children. Then all questions concerning current childcare are asked. After that care responsibilities for older incapacitated relatives are identified with Q3 which completes sub-module 1.

Care responsibilities are assumed to exist for all respondents' and spouses' or cohabiting partners' children up to the age of 14 who live inside the household. Countries may retrieve the corresponding information from the LFS core for routing in the module and determining CARERES. They do not need to ask Q1\_careres and can start the module with Q2\_careres.

*Own children* means natural, adopted, foster and step-children. Legally seen foster children are no relatives; but taking over care responsibilities for them is binding and has a significant effect. Grandparents, who are legal guardians should also be considered as having care responsibilities. As care responsibilities are often shared in a family or household, questions on "own children" *always* include the ones of the spouse or cohabiting partner.

Whether a child is counted as living in- or outside the household is derived from its categorisation in the LFS core and if it is counted as household member there.

Examples of *caring tasks for own children* comprise personal care, homework, playing games, reading, taking out, giving a ride, and supervision, among others. If care consists only in financial support, is not to be included.

*Carers for incapacitated relatives* (from the age of 15) are defined as people who look after or provide help to relatives or the partner in need of care because they are sick, elderly or disabled. This also includes the relatives of the spouse/cohabiting partner and is irrespective of whether they live in the same household or not. Corresponding examples of caring tasks are personal care (e.g. dressing, washing, feeding), physical help (e.g. walking), support in health care, giving a ride, helping with paperwork or financial matters, domestic help (e.g. housework, laundry, groceries).

Disabled children up to the age of 14 should be counted as children. Disabled children from the age of 15 should be counted as 'relatives' in need of care.

The care for children living outside the household or incapacitated relatives should only be considered if it is regular, meaning at least some hours per week. It can also be alternating like every second week but on average should be at least several hours per week. Respondents who take care only during certain periods of the year should refer to the situation in the reference week. If the respondent takes regularly care of the partner's children outside the household this also should be counted but not if the partner has children living elsewhere and the respondent does not or only occasional take care.

Caring for non-relatives, care as a job, for charity or done as a volunteer shall not be counted, here.

## CHCARUSE Col 212

### *Use of childcare services*

#### **Purpose**

This variable establishes if all children a respondent takes care of are also looked after by professional care services. This information can be used to assess if parents' participation in labour market depends on the use of such services.

Even though the variable makes no explicit reference it clearly aims at the use of services that facilitate employment and are formal or professional, respectively.

To be able to determine the influence of care responsibilities on employment exactly, the care situation for each child would have to be identified. As the number of variables in the ad-hoc module is limited the so called "at least one care intensive child" approach is used as a proxy. It assumes that already one child who receives no additional care from a professional childcare service could need significantly more care by its parents and limit the parents in their employment possibilities. Thus, this variable distinguishes if professional care services are used for all, not all or none of the children of a parent.

#### **Explanatory Notes**

The variable refers to care services used for own children living in- and outside the household up to the age of 14.

*Professional childcare services* comprise all forms of care organised by private or public structures like the so called centre based pre-schools, nursery schools (which normally are assigned to ISCED level 0), day care centres, crèches or after school centres. Also included is organised family care or care by professional childminders arranged with an intermediate service or directly employed by the family. The care can take place in the household, at the carer's home or at a facility. Organised services are included irrespective of direct payments by the parents (could e. g. be subsidised by the state or the employer). Childminders that are engaged directly by the parents have to be paid to be seen as a professional service and counted for this variable. Professional means that the childminder is undertaking his/her job as a real profession (with an own registered business) not as side-activity that provides some extra money.

Relatives, other household members, friends or neighbours who look after children without the professional aspect are seen as *informal* care and not counted as care services, here. This applies also to occasional caring by "baby-sitters" even if there is some kind of payment. If children join sports clubs/lessons, language courses or comparable activities this is not be considered as childcare.

If the child is a pupil and the school provides extra supervision besides regular school hours this should be considered, too. Classes in the afternoon are no childcare.

The question relates to the normal situation. School holidays or singular situations should not be taken into account.

The use is counted no matter if it is part- or full-time. But it should be relevant for labour market participation. It should be regular and can also be alternating like every second week. A minimum threshold is difficult to define because the use can heavily depend on the care responsibilities and employment of the respondent.

In case the child lives outside the household and a professional care service is organised by the other parent outside the household, this is still to be counted as having it cared for by a professional service.

## CHCAROBS Col 213/214

### *Factors for not using childcare services*

#### **Purpose**

This variable identifies the main reason why professional childcare services are not used or not used for all children by a household. The variable tries to catch the supply (obstacles) as well as the demand side. Empirical results indicate that focussing on the supply side is not enough. A large number of parents do not demand more care services as they have organised care in another way to fit their needs. This may include the organisation of informal care support or the adaptation of their employment situation. Whether these arrangements result from personal attitudes towards upbringing or are the result of adapting to the care infrastructure in the past, cannot be clarified with this variable. It is also possible that parents do not need care because their children are already old enough to stay alone by themselves.

The variable can provide policymakers with the idea for whom the improvement of care service could really be a help for reconciliation. It can reveal if mainly the availability of services, its costs or the kind and quality are a problem. For those who do not demand additional services it can give a better understanding of how they organised their care responsibilities.

#### **Explanatory notes**

The definition of professional childcare service can be found under **Error! Reference source not found.**

The variable collects the main reason for not using professional childcare services. The respondent has to decide what the most important reason is even though there might be a combination of reasons on the supply as well as on the demand side. This may especially be the case when there are several children of quite different ages in one household.

If professional childcare services are used for some children, the answer should refer to the ones for which they are not used. If there is more than one child without professional care in a household and their age diverges more, the main problem with the childcare infrastructure could be different, too. No vacancy in the creches for the young child and only religious kindergardens for the older child. In that case the respondent should answer what he/she perceives as the more important or sustainable limitation

The variable should refer to the current situation.

Answer 1 on *availability* in Q1 should be chosen when no service exists in the household's catchment area or existing ones have no vacancies. It might also be that a child has no access because it is not eligible to use the service (e. g. child is too young, the parents' income is too high or other social criteria, the child has to belong to a certain confession etc.) or existing services are full. The relevant catchment area of a household depends on its individual assessment and possibilities.

If the respondent considers the *costs* as main problem the household either cannot afford to pay the fees or considers them as disproportionately high. If the indirect costs like for transport, meals or special clothing (in addition) are decisive this should also be counted here.



*Quality* can address the qualification of the personnel, the capability to serve particular care needs or the state of the facilities/building. Available services could have a specific confessional or pedagogical orientation (e. g. Montessori, Waldorf) that might not fit the household's preferences.

If there are other problems stemming from the existing offer of care services category (4) should be chosen. If care services cannot be used because opening hours do not fit the needs of the household this should also be counted as *other reason concerning the offer of services*. For national purposes countries this can be collected as distinct category.

If a household currently does not want or need (additional) professional care services independent from the characteristics of the offer the respondent should choose category (5).

Q2 catches the main reason why there is no need or interest:

Category (1) applies to couples that found their arrangement to bring up their children by sharing care responsibilities and by adapting the way and volume of their employment. The same applies to single parents who manage their care responsibilities on their own.

(2) Parents who use additional *informal* care support from grandparents, other relatives or friends.

(3) This category only applies to respondent who use some professional care services and should only be presented to them (who have answered (2) in Q1\_chcaruse). It should be chosen when respondents don't want to use more professional care services because they considered the received support being enough. It can overlap with other modalities of this question as some care still has to be arranged privately in the household or the children might be independent enough Respondents should choose it when it is the most important category for them not needing/wanting more care.

(4) The children for who the respondent has care responsibilities for can already take care for themselves, also by caring for younger siblings inside a household.

(5) Other reasons for not wanting or needing professional care services.

## CHCAREFF Col 215

### *Use of childcare services*

#### **Purpose**

This variable assesses if and how respondents adapt their employment because of care responsibilities for their or their partner's children. People who stopped working provided this information already in the core variable LEAVREAS. This variable provides more detailed information on carers still in employment. It additionally covers the situation mostly of men who increase their workload to earn enough money for the bigger family and it covers also a change of tasks in the job or of the employer which might allow better reconciliation.

The variable can help to consider effects on employment in a more differentiated and qualitative way. It can help to analyse effects that cannot be assessed by only looking on the volume of work.

#### **Explanatory notes**

The variable refers to the current care responsibilities for children as identified by CARERES and to persons who are in employment. They might have been at work in the reference week or not. The change in their employment because of care responsibilities may have taken place some time ago and it plays no role if the respondent plans to revert if the care responsibilities do not exist anymore.

It is recommended to implement question version 1.4.2.1 with one question presenting to the respondent directly a list of possible effects. The answer categories should be read out completely before the

respondent answers. This directly points at the intention of the question and supports the answering process of the respondent. If the answer list is perceived as too long e.g. in countries that conduct telephone interviews, the second version using an additional introductory question (1.2.2.2) is an alternative.

A respondent who did something to increase his/her income should choose answer category (1). A change might be necessary simply because the increase in expenditure for the new family member cannot be covered or the person becomes the sole breadwinner while the partner cares for the child. The change could mean an increase of working hours or taking over a job with more responsibilities and thus a higher salary. It could be a change of the employer or taking over an additional job.

Categories (2) and (3) address changes that have been undertaken in the existing job. If a person has several jobs a change in any job should be counted. E. g. if s/he reduced working hours in one (or several) job(s) or has given up one (or several) job(s) s/he should choose answer (2).

Category (4) should be chosen if the respondent changed jobs or employer in order to facilitate reconciliation of their work with care responsibilities. This might have been necessary because it was not possible to reduce working hours or tasks in that job or because the new job offers more working time flexibility or is located more suitably. Any change in order to increase the income is already covered by answer (1).

Answer category (5) does not cover temporary short-term maternity or paternity taken as long as it does not last more than 14 weeks (minimum according to EU legislation) or annual leave. They should not be counted as an effect. Respondents who are interviewed during maternity/paternity or holidays should refer to the situation after the end of that leave. If they plan to change something but don't know exactly what, they should choose other effect (7). Respondents who took more than their annual leave, like an unpaid leave, should choose modality (7) as long as it is not covered by some legal regulation or collective agreement as family leave. In the latter case (5) should be chosen.

Respondent might change their working times without changing the overall working hours. They might start later in the morning (and leave work later) to be able to bring their children to school. They might accumulate hours on some days in a week and take off on one where no other care is available etc. These adaptations are covered by answer option (6).

## **POSSTEND Col 216**

### *Working time flexibility for care*

#### **Purpose**

The aim of POSSTEND is to evaluate the actual degree of flexibility in the main job in terms of reconciliation with care responsibilities as a usual and exceptional mean. POSSTEND focuses on the possible variation of the start and/or end of a working day by at least one hour.

This should give a picture in how far parents can gain additional flexibility to facilitate reconciliation. It has to be kept in mind that persons with care responsibilities who are not informed about it might tend to answer "no". Thus, this variable gives an indication of the share of employed respondents who are generally interested in /informed about using this means of flexibility and can use it.

#### **Explanatory notes**

Formal and informal working arrangements should be taken into account.

Hours taken off are normally made up later/earlier. But they are not always necessarily compensated in terms of hours done: the fact that the job is done is enough and this should be included.

(1) The person can generally start later and/or finish earlier either in general or to fulfil their care responsibilities (explanation of care responsibilities for children or dependent relatives are given under 1.1.4).

(2) The person can start later and/or finish earlier fulfilling care responsibilities, but only rarely or not generally. This covers cases when it is only possible in cases of emergencies.

(3) The person cannot start later and/or finish earlier neither in general nor for specific care related reasons. Respondents for whom this question is not relevant because of their special workplace, e.g. oil-platform workers, should also be coded here.

(4) Respondents who are not informed about their possibilities to adapt the start and end of working times should not choose category (3) but answer with "don't know" (4).

## **POSORGWT Col 217**

*Flexibility for taking whole days off for care*

### **Purpose**

The aim of POSORGWT is to evaluate the actual degree of flexibility of the main job in terms of reconciliation with care responsibilities as a usual and exceptional mean. POSORGWT extends the information surveyed through POSSTEND by asking for the possibility to organise the working time in order to *take whole days off* while regular holidays are not used up.

This should give a picture in how far parents can gain additional flexibility to facilitate reconciliation. It has to be kept in mind that persons with care responsibilities who are not informed about this possibility might tend to answer "no". Thus, this variable gives an indication of the share of employed respondents who are generally interested in /informed about using this means of flexibility and can use it.

### **Explanatory notes**

Formal or informal working arrangements should be taken into account. It includes arrangements that are generally available for all employees or specifically only for persons with children and/or incapacitated or elderly relatives. Possible arrangements are working time banking with the possibility to take whole days off or the general possibility to be absent from work for a day without any special arrangement.

Using up the personal annual leave/holidays to take care for children or incapacitated relatives is not meant, here. Days taken off are normally made up earlier/ later but do not necessarily have to be compensated. An employer might offer a number of additional days that can be taken off in case of emergencies or for personal business. In such cases and depending on the maximum number of those days the respondent has to decide if that means answer 1 or 2.

It is not relevant whether the days taken off are paid or unpaid – only the question whether it is possible to take days off is addressed.

(1) The person can generally organise his/her working time to take whole days off to be able to care for own or partner's children or for older dependent relatives. They can do this either because of their general working time arrangement (like working time banking) or because of particular rights they have because of their care responsibilities.

(2) The person can organise the working time in order to take whole days off for taking care responsibilities, but only rarely, in cases of emergency but not generally.

(3) This code applies to persons who cannot organise the working time in order to take whole days off, even not in exceptional circumstances.

(4) Respondents who are not informed/do not know about their possibilities to adapt the start and end of working times should not choose category (3) but answer with "don't know" (4).

## **WORKOBS Col 218**

*Main obstacle at work for reconciliation*

### **Purpose**

This variable assesses if the main job makes caring more difficult and if so which characteristic is most problematic. It looks at reconciliation from the side of work and complements the information coming from CHCAREFF and LEAVREAS. While CHCAREFF provides information about the effect of the care responsibilities on the current employment WORKOBS shows if the main job is seen as a problem for properly fulfilling care responsibilities. It is only asked to people in employment. It can also reveal if persons who (can) use one or several flexible work arrangements offered by their employer report less problems.

### **Explanatory Notes**

This variable covers all persons in employment with care responsibilities.

It asks for the main obstacle in the main job for fulfilling care responsibilities. If the respondent sees several characteristics of the main job being problematic s/he should choose the one having the most negative consequences.

It is recommended to implement question version 2.3.2.1 with one question with the answer categories being read out completely before the respondent answers. In this way it is directly clarified what kind of obstacles are meant and supports the answering process of the respondent. If the answer list is perceived as too long e.g. in countries that conduct telephone interviews, the second version using an additional introductory question (2.3.2.2) is an alternative.

Category (5) applies e. g. to respondents who might in principle have the possibility to organise work in accordance with their care responsibilities but colleagues or the supervisor do not approve of that.

Respondents who have a non-fixed working place and see that as main obstacle should be coded under (6).

## **STOPWORK Col 219**

*Career break for childcare*

### **Purpose**

This variable identifies persons who have interrupted their employment for at least one month to take care for children during their course of life. This also includes persons who had completed their education but did not directly start to work because they wanted to raise their children, first. Persons who never worked are also asked if the main reason for not working was the upbringing of their children.

The results of this variable can help to identify the care related absences and their effects labour market outcomes with respect to e.g. gender, age and education. The effect of interruptions on the professional career and salaries can be assessed by looking at the current labour market situation. Because of very different kinds of interruptions and durations from a few days up to a complete retreat from the labour

market, a sensible interpretation can only be done in combination with STOPLENG. It thus serves mainly as a filter variable, to find out if the person had any kind of career interruption or delay because of childcare responsibilities.

Identifying the persons who never had children helps to calculate the share of parents who continue working and those who have a career break.

### **Explanatory notes**

Respondents get different questions depending on whether they have ever worked or not. If yes, they are asked if they ever stopped working for care reasons for at least one continuous month. If they have never worked, they are asked if the main reason that for was child care.

"Not working" means that the respondent did not work in his/her employment to be able to take care of own children. The employment as such may continue and the phase of not working may be a formal family leave in its various forms like maternity, paternity or (full-time) parental leave or a leave on other grounds. It may be a legally guaranteed leave, one agreed on industry level, with the employer in a formal or informal way. The person may have left his/her job completely (ended his/her employment) with the intention to return to employment or not.

It is also counted as a work interruption if a person has completed his/her education being able to enter the labour market, but doing so only later because he/she first wants to care for the own children. Persons who quit employment for another reason but remained being out of the labour force because of care responsibilities should also answer Q2 with 'yes'.

There has to be an episode of work interruption (or delayed entry) of at least one month. Several short episodes that add up to one month is not enough.

Interruptions for children that were only taken above age of 14, e. g. because of a suddenly emerging illness or handicap, are not covered by this variable but by DEREDSTP. Respondents who raised their grandchildren to a wide extend (while the parents still remain the legal guardians) should not [be](#) considered for this question.

Respondents who never had children, including adopted children, foster children or the partner's children, should choose modality (3). Parents who put up a child for adoption should choose that category, too.

Persons who stayed away completely from the labour market mainly because they took care of their children are counted in an extra category (STOPWORK=2). They are identified through the second version of the question.

Mother protection leaves (maternity) are included because they are defined quite differently in the EU countries. The minimum length specified by the EU is 14 weeks of which two are mandatory. Germany and Sweden apply to this minimum of 14 weeks. Depending on the number of children or health conditions maternity leave can be extended and can be as long as one year in the UK and 58 weeks in Bulgaria. Maternity is not (completely) mandatory in every country. The continuation of payment is settled quite differently, too. To insure comparability and facilitate the answering all kinds of interruptions have to be counted in the ad-hoc module.

The prenatal phase of maternity is to be included.

Regular holidays, even if they are especially used for childcare, should not be counted as an interruption.

The answer options have to be read out before the respondent answers.

Countries who want to direct the interview more by filtering out respondents who never raised children or who also want to collect the number of children raised (not given birth to) should apply the alternative model questions (3.1.2.2). The number of children can be used for national purposes while this information is no provided to Eurostat.

## **STOPLENG Col 220**

*Complete length of career breaks for childcare*

### **Purpose**

Measure the overall length of all work interruptions due to childcare including the duration of a delayed entry into the labour market. It is not the target to get absolutely precise estimations but an approximation.

The variable helps to assess the impact of care responsibilities on labour market participation as it measures how long a person stays in total away from work. It can be expected that longer interruptions have a stronger, presumably negative impact. Comparative analysis by gender, cohort, educational attainment or country can reveal the differing strength of such effects. Factors influencing the length of the interruption are not investigated.

### **Explanatory notes**

Respondents should provide the sum of the durations of ALL interruptions of at least one month. All interruptions have to be related to the caring for an own child.

Interruption means that the person does not work at all as defined for STOPWORK but may be in employment. The whole time span for an interruption should be counted from the point a person stops working to the point when the person takes up work again. It is the fact of taking up work again that indicates the end of the interruption not how long care is needed or provided. Thus, a woman who returns to work after eight years counts the whole eight years even though her child from the age of four was sent to care centres and educational institutions for most of the day. Also, if she did some other kind of work like volunteering in between or was unemployment for a longer period, this would be counted as part of the interruption.

If the respondent has not returned to work in the reference week the total duration until then is counted.

Respondents who did not start working directly after finishing their initial education should also include this delay into their estimation. They should consider the time span between leaving the educational system and taking up employment.

The information is collected in brackets. They should be read out before the respondent answers. They help to indicate the required level of detail.

## **PARLEAV Col 221**

### *Use of parental leave*

#### **Purpose**

This variable provides the information if parents take a part of their work interruption as full-time parental leave and how they combine it with maternity or paternity, respectively. It can give a picture of how frequently both forms of family leave are taken and if both partners of couples take advantage of it. It can also help to assess if family leaves influence the length of the interruption and the current labour market situation of the respondent.

Information on maternity/paternity is collected to complement the information on parental leave. In many countries it is more than a mere protection of mother and child around the birth. Thus, there may be also complementary relations between maternity/paternity and parental leave.

#### **Explanatory notes**

This question is only asked to respondents who indicated an interruption of their work for childcare.

An EU council directive stipulates a right to parental leave but sets out no definition and leaves the conditions of access to parental leave to be defined by national law or collective agreements. Parental leave is organised in very different ways in the EU member states. A common characteristic is that it can be taken on the birth or adoption of a child to stay away from work for a certain period of time and that the parent shall have the right to return to the same or an equivalent job. The loss of salary during parental leave can but does not have to be compensated.

Due to the diverse national forms of parental leave the statistical implementation of the concept has to be left to the member states. But only full-time parental leave may be taken into consideration.

In some countries, there exist forms of parental leave that have no relation to employment or a job. Those forms are not to be counted, here.

The forms of parental leave that are taken in to account in the national LFSs should be in line with the above mentioned council directive. NSIs should report the characteristics of the covered and excluded family leaves ideally with the data transmission for the ad-hoc module and in the quality reports.

## **DEREDSTP Col 222**

### *Career break for incapacitated relatives*

#### **Purpose**

This variable assesses the impact of care responsibilities for incapacitated relatives on labour market participation or the volume of working hours.

It provides information on how often people stop working to take care for ill, disabled or elderly relatives or at least reduce their weekly working time. Furthermore, it tries to assess how many people have been in the situation that they had to care for an older dependent. Thus, it helps to assess which groups (e. g. gender or age) are mainly confronted with that situation. It gives an indication on how common this possible effect of the ageing society on labour market participation already is.

It also gives the possibility to see if persons who already had adapted their labour market participation for children are more likely to do the same for older relatives in need for care.

### **Explanatory notes**

The variable refers to ill, disabled or elderly relatives, from the age of 15 and who are in need of care. Care for non-relatives should not be taken into consideration. Own children from the age of 15 are included, too.

This variable covers career breaks or reductions of working time for older dependents in a concise way but the focus is on complete work interruptions. Only in cases the respondents did not stop working he/she is asked if he/she at least reduced working time to take care of a relative in need of care.

Persons who never were in a situation with responsibilities for incapacitated relatives should choose the corresponding answer category (3).

Stop working can be a temporary interruption of a job, quitting a job or taking a special care leave. Regular holidays should not be counted as an interruption. Reduced working time could be a daily reduction of working hours or not coming to work for some days during the week. The reduction can base on formal or informal agreements, on special leave schemes agreed for a branch or legally defined. It does not matter if the respondent who reduced already worked part-time or if he/she reduced from long working hours to a normal full-time job.

The minimum duration of interruption or reduction is one month. The reduction/interruption must be real thus not achieved by using up holidays or compensation via working time banking or flexitime. Normally it has consequences on the salary. If there are special care schemes that e. g. compensate salary loss or guarantee a return to the former work place of volume of working hours it is still counted as interruption or reduction, respectively.



**Specifications of the 2017 ad hoc module on self-employment**

Column	Code	Description	Filters/remarks	
211	MAINCLNT	<b>Sub-module 1: Economically dependent self-employment</b>	STAPRO = 1,2	
		<b>Economic dependency</b>		
		<i>Number and importance of clients in the last 12 months</i>		
		1		No client in the last 12 months
		2		Only one client in the last 12 months
		3		2-9 clients in the last 12 months, but one was dominant
		4		2-9 clients in the last 12 months, and none was dominant
		5		More than 9 clients in the last 12 months, but one was dominant
		6		More than 9 clients in the last 12 months, and none was dominant
		9		Not applicable (not included in the filter)
Blank	No answer / Don't know			
212	WORKORG	<b>Organisational dependency</b>	STAPRO = 1,2 and MAINCLNT ≠ 1	
		<i>Influence over deciding working hours</i>		
		1		The respondent decides
		2		The client/s of the respondent decide(s)
		3		Any other party decides
		9		Not applicable (not included in filter)
Blank	No answer / Don't know			
213	REASSE	<b>Sub-module 2: Working conditions for self-employed</b>	STAPRO = 1,2	
		<b>Main reason for becoming self-employed</b>		
		<i>Main reason for becoming self-employed when starting to work as self-employed in the current job</i>		
		1		Could not find a job as an employee
		2		The respondent's former employer requested the respondent become self-employed
		3		It is usual practice in the respondent's field
		4		A suitable opportunity presented itself
		5		Continued the family business
		6		Did not want to or plan to become self-employed, but started working as self-employed for another reason than listed previously
		7		Wanted to be self-employed because of flexible working hours
		8		Wanted to be self-employed for other reason
9	Not applicable (not included in filter)			
Blank	No answer / Don't know			

## Specifications of the 2017 ad hoc module on self-employment, cont'd

Column	Code	Description	Filters/remarks
214	SEDIFFIC	<p style="text-align: center;"><b>Main difficulty as self-employed</b></p> <p><i>Self-perceived main difficulty working as self-employed</i></p> <p>0 Lack of influence on setting the price of own work                      1 Lack of access to financing for the business                      2 Delayed payments of non-payments                      3 Inappropriate levels of administrative burden                      4 Lack of income in case of sickness                      5 Periods of financial hardship                      6 Periods of having no customer, assignments or projects to work on                      7 Other difficulty                      8 Had no difficulties                      9 Not applicable (not included in filter)                      Blank No answer / Don't know</p>	STAPRO = 1,2
215	REASNOEM	<p style="text-align: center;"><b>Main reason for not having employees</b></p> <p><i>Self-perceived main reason for not having employees</i></p> <p>0 Respondent primarily wants to employ him/herself                      1 There is not enough work                      2 Difficult to find suitable staff                      3 Legal framework is too complicated                      4 High social contributions                      5 Not possible in respondent's occupation                      6 Respondent prefers to work with sub-contractors or associates                      7 The respondent's client/s want(s) the respondent to do the work                      8 Other reason                      9 Not applicable (not included in filter)                      Blank No answer / Don't know</p>	STAPRO = 2
216	BPARTNER	<p style="text-align: center;"><b>Working with business partners</b></p> <p><i>Working with a co-owner and/or in a network of other self-employed</i></p> <p>1 Works with a co-owner                      2 Works together with other self-employed in a network                      3 Both                      4 Neither                      9 Not applicable (not included in filter)                      Blank No answer / Don't know</p>	STAPRO = 1,2

**Specifications of the 2017 ad hoc module on self-employment, cont'd**

Column	Code	Description	Filters/remarks
217	PLANEMPL	<p><b>Planned hiring of employees or making use of subcontractors in the next 12 months</b></p> <p><i>Plans to employ or subcontract in the next 12 months</i></p> <p>1 Plans to employ only permanent employees                      2 Plans to employ only temporary employees                      3 Plans to employ both permanent and temporary employees                      4 Plans only to make use of subcontractors                      5 Plans to make use of subcontractors and employ employees                      6 Does not plan to hire or subcontract                      9 Not applicable (not included in filter)                      Blank No answer / Don't know</p> <p><b>Sub-module 3: Comparing employees and self-employed</b></p>	STAPRO = 1, 2
218	JBSATISF	<p><b>Job satisfaction</b></p> <p><i>The level of job satisfaction in the main job</i></p> <p>1 Satisfied to a large extent                      2 Satisfied to some extent                      3 Satisfied to a small extent                      4 Not satisfied at all                      9 Not applicable (not included in filter)                      Blank No answer / Don't know</p>	WSTATOR = 1, 2
219	AUTONOMY	<p><b>Appropriateness of job given the respondent's level of education</b></p> <p><i>The level of influence over content and order of tasks in the main job</i></p> <p>1 Able to influence both contents and order of tasks                      2 Able to influence contents but not order of tasks                      3 Able to influence order but not contents of tasks                      4 Not able to influence contents, nor order of tasks                      9 Not applicable (not included in filter)                      Blank No answer / Don't know</p>	WSTATOR = 1, 2

**Specifications of the 2017 ad hoc module on self-employment, cont'd**

Column	Code	Description	Filters/remarks
220	PREFSTAP	<p style="text-align: center;"><b>Preferred professional status for the main job</b></p> <p><i>Preference to work as an employee if currently self-employed, or preference to work as self-employed if currently working as an employee</i></p> <p>1 Does not want to change professional status</p> <p>2 Is self-employed but wishes to work as an employee</p> <p>3 Is working as an employee or family worker but wishes to be self-employed</p> <p>9 Not applicable (not included in filter)</p> <p>Blank No answer / Don't know</p>	WSTATOR = 1, 2
221	CMT4JOB	<p style="text-align: center;"><b>Main reason for not becoming self-employed in the main job</b></p> <p><i>The main reason why the current employees or family workers who wish they self-employed have not switched to their preferred professional status</i></p> <p>1 Financial insecurity</p> <p>2 Difficulties with getting financing for the business</p> <p>3 Too much stress, responsibilities, or risk</p> <p>4 Less coverage from social protection</p> <p>5 Other reason</p> <p>9 Not applicable (not included in filter)</p> <p>Blank No answer / Don't know</p>	PREFSTAP = 3

MAINCLNT : Economic dependency  
(Eurostat AHM 2017 Col 211)

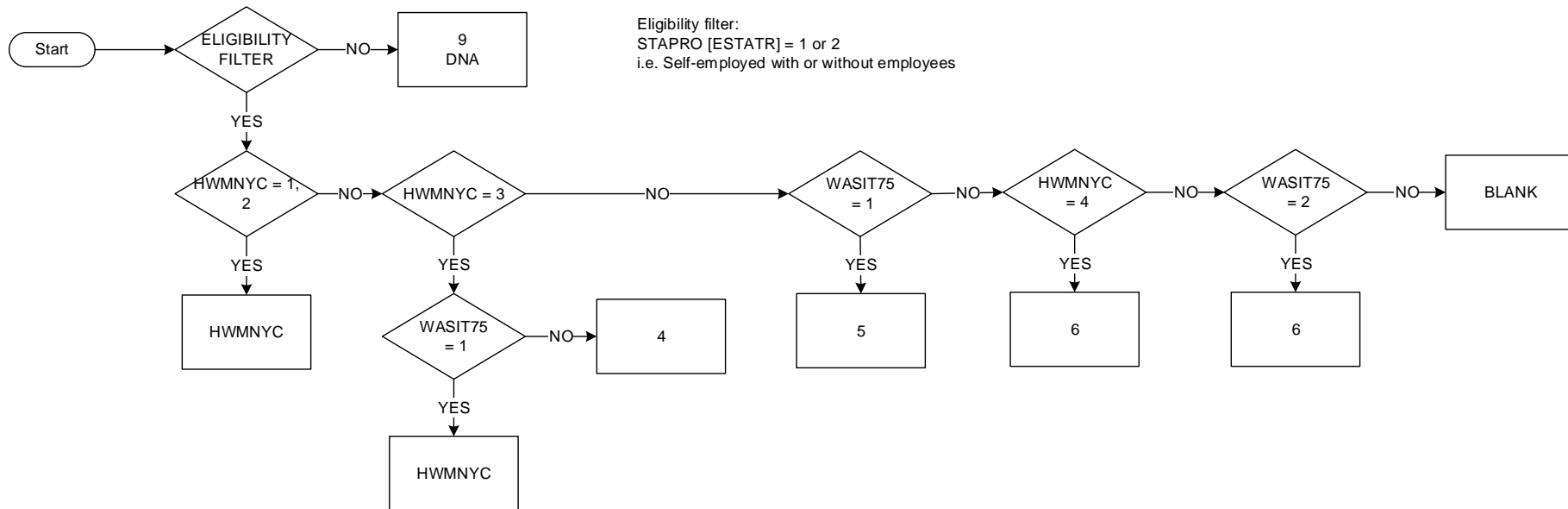

Key	
Number and importance of clients in last 12 months	
1	No client in last 12 months
2	Only one client in last 12 months
3	2-9 clients in last 12 months, but one was dominant
4	2-9 clients in last 12 months, and none was dominant
5	More than 9 clients in last 12 months, but one was dominant
6	More than 9 clients in last 12 months, and none was dominant
9	Not applicable (not included in filter conditions)
Blank (-8)	Unknown

WORKORG : Organisational dependency  
(Eurostat AHM 2017 Col 212)

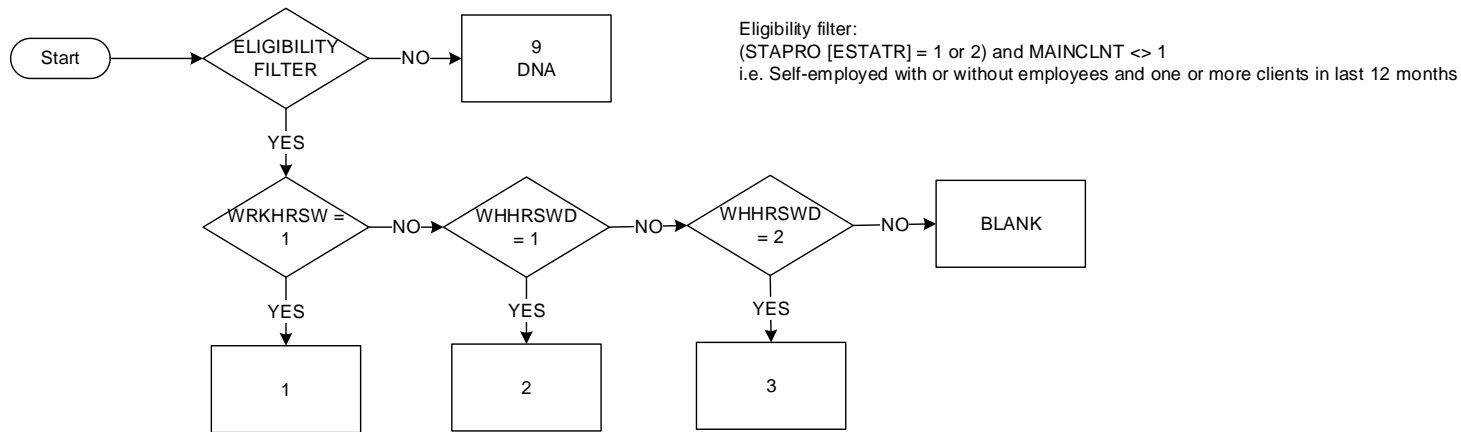

Key  
Influence over deciding working hours  
1 The respondent decides  
2 The client/s of the respondent decide(s)  
3 Any other party decides  
9 Not applicable (not included in filter conditions)  
Blank (-8) Unknown

REASSE : Main reason for becoming self-employed  
(Eurostat AHM 2017 Col 213)

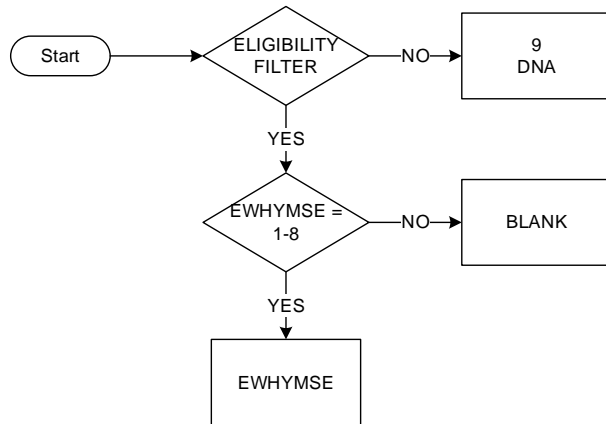

Eligibility filter:  
STAPRO [ESTATR] = 1 or 2  
i.e. Self-employed with or without employees

Key

Main reason for becoming self-employed when starting to work as self-employed in the current job

- 1 Could not find a job as an employee
  - 2 The respondent's former employer requested the respondent to become self-employed
  - 3 It is the usual practice in the respondent's field
  - 4 A suitable opportunity presented itself
  - 5 Continued the family business
  - 6 Did not want to or plan to become self-employed, but started working as self-employed for another reason than listed previously
  - 7 Wanted to be self-employed because of flexible hours
  - 8 Wanted to be self-employed for other reason
  - 9 Not applicable (not included in filter conditions)
- Blank (-8) Unknown

SEDIFFIC : Main difficulty as self-employed  
(Eurostat AHM 2017 Col 214)

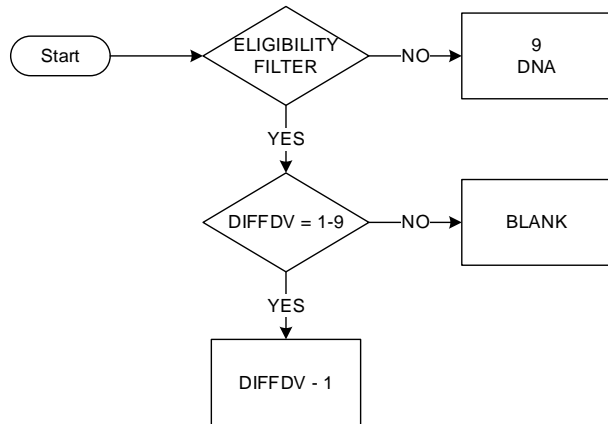

Eligibility filter:  
STAPRO [ESTATR] = 1 or 2  
i.e. Self-employed with or without employees

Key	
Self-perceived main difficulty working as self-employed	
0	Lack of influence on setting the price of own work
1	Lack of access to financing for the business
2	Delayed payments or non-payments
3	Inappropriate levels of administrative burden
4	Lack of income in case of sickness
5	Periods of financial hardship
6	Periods of having no customer, no assignments or project to work on
7	Other difficulty
8	Had no difficulty
9	Not applicable (not included in filter conditions)
Blank (-8)	Unknown



REASNOEM : Main reason for not having employees  
(Eurostat AHM 2017 Col 215)

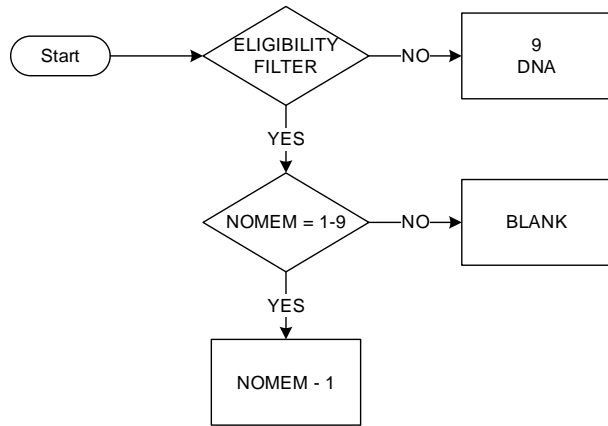

Eligibility filter:  
STAPRO [ESTATR] = 2  
i.e. Self-employed without employees

Key	
Self-perceived main reason for not having any employees	
0	Respondent primarily wants to employ him/herself
1	There is not enough work
2	Difficult to find suitable staff
3	Legal framework is too complicated
4	High social contributions
5	Not possible in the respondent's occupation
6	Respondent prefers to work with sub-contractors or associates
7	The respondent's client/s want(s) the respondents to do the work
8	Other reason
9	Not applicable (not included in filter conditions)
Blank (-8)	Unknown

**BPARTNER : Working with business partners**  
(Eurostat AHM 2017 Col 216)

Start date: Jan 2017  
End date: Dec 2017

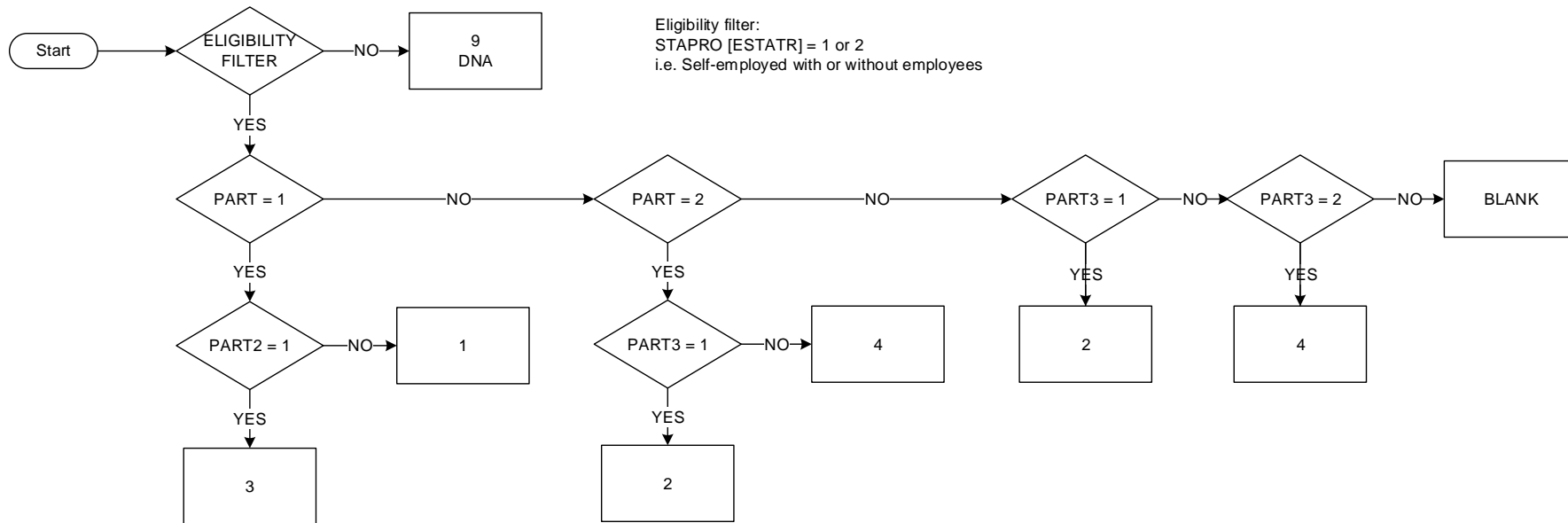

Eligibility filter:  
STAPRO [ESTATR] = 1 or 2  
i.e. Self-employed with or without employees

**Key**  
Working with a co-owner and/or in a network of other self-employed  
1 Works together with a co-owner  
2 Works together with other self-employed in a network  
3 Both  
4 Neither  
9 Not applicable (not included in filter conditions)  
Blank (-8) Unknown

PLANEMPL : Planned hiring of employees or making use of subcontractors in the next 12 months - alt  
(Eurostat AHM 2017 Col 217)

Start date: Jan 2017  
End date: Dec 2017

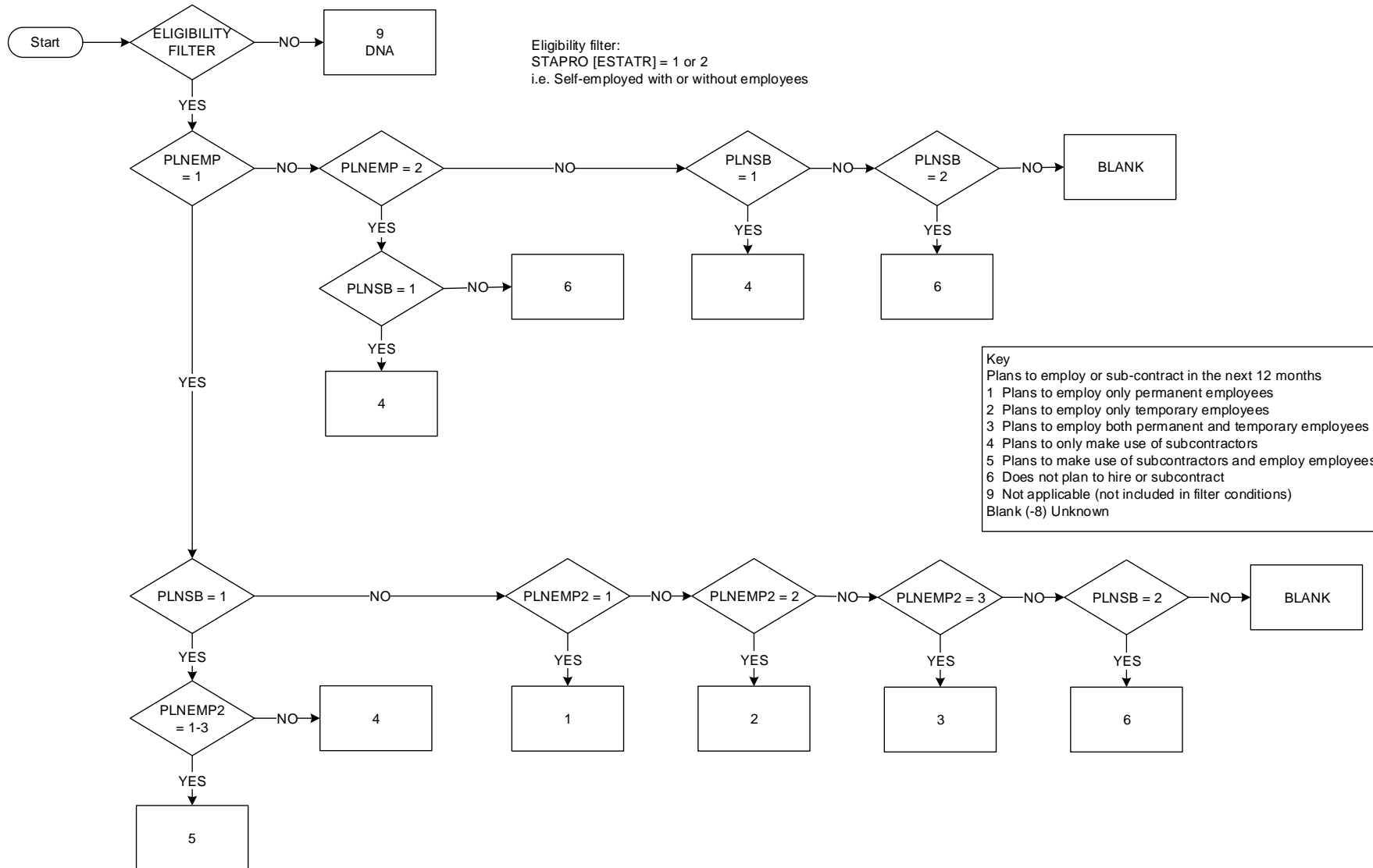

JBSATISF : Job satisfaction  
(Eurostat AHM 2017 Col 218)

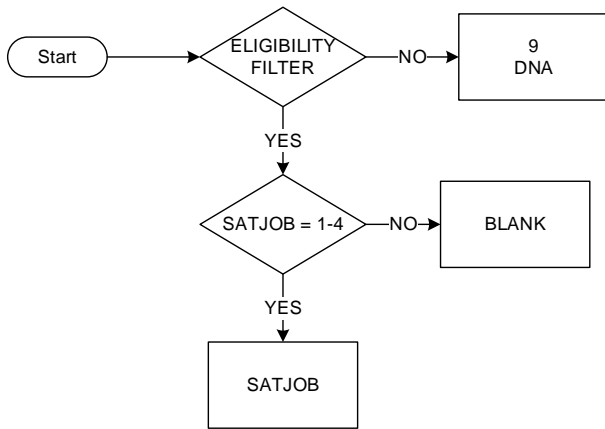

Eligibility filter:  
WSTATOR [EWKSTATR] = 1 or 2  
i.e. Worked in reference week or was absent from a job

Key  
The level of job satisfaction in the main job  
1 Satisfied to a large extent  
2 Satisfied to some extent  
3 Satisfied to a small extent  
4 Not satisfied at all  
9 Not applicable (not included in filter conditions)  
Blank (-8) Unknown

**AUTONOMY : Job autonomy**  
(Eurostat AHM 2017 Col 219)

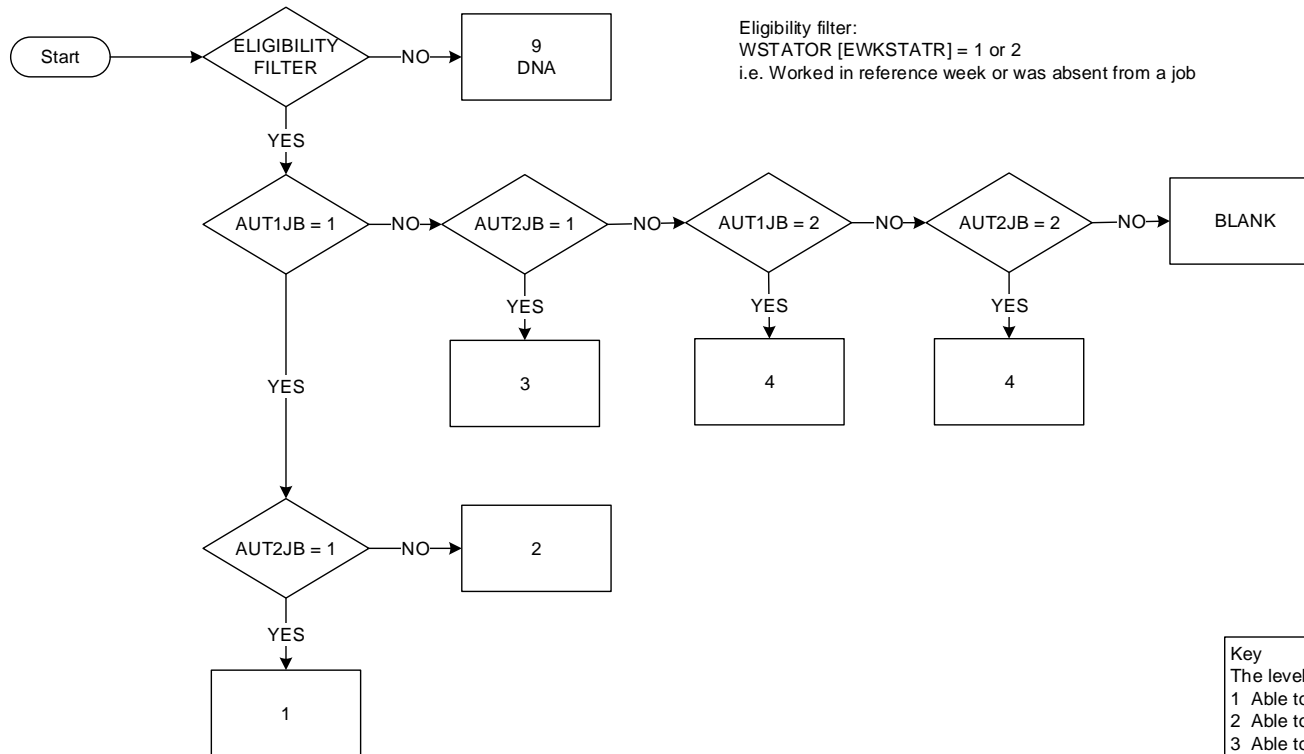

Eligibility filter:  
WSTATOR [EWKSTATR] = 1 or 2  
i.e. Worked in reference week or was absent from a job

**Key**  
The level of influence over content and order of tasks in the main job  
1 Able to influence both contents and order of tasks  
2 Able to influence contents but not order of tasks  
3 Able to influence order but not contents of tasks  
4 Not able to influence contents nor order of tasks  
9 Not applicable (not included in filter conditions)  
Blank (-8) Unknown

PREFSTAP : Preferred professional status for the main job  
(Eurostat AHM 2017 Col 220)

Start date: Jan 2017  
End date: Dec 2017

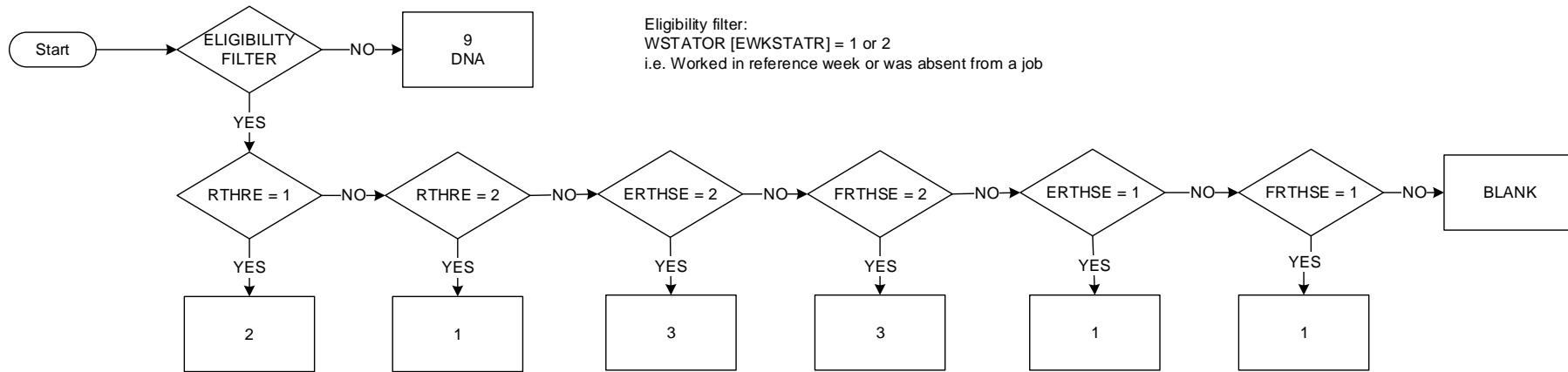

Key  
 Preference to work as an employee if currently self-employed or preference to work as self-employed if currently working as an employee  
 1 Does not want to change professional status  
 2 Is self-employed but wishes to work as an employee  
 3 Is working as an employee or family worker but wishes to be self-employed  
 9 Not applicable (not included in filter conditions)  
 Blank (-8) Unknown

OBSTACSE : Main reason for not becoming self-employed in the main job  
(Eurostat AHM 2017 Col 221)

Start date: Jan 2017  
End date: Dec 2017

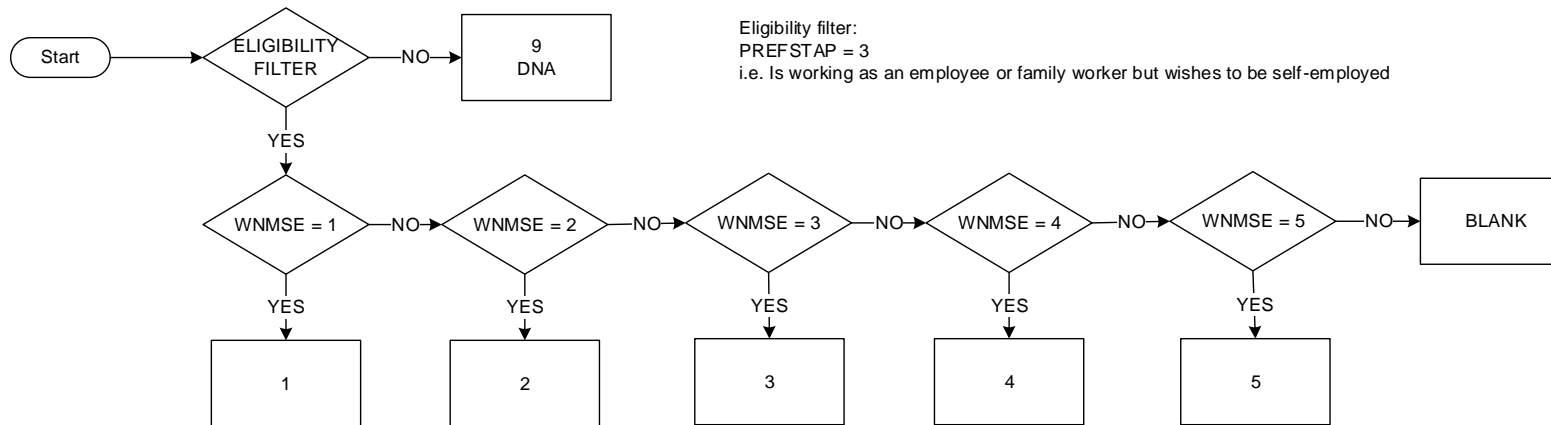

Eligibility filter:  
PREFSTAP = 3  
i.e. Is working as an employee or family worker but wishes to be self-employed

**Key**  
The main reason why current employees or family workers who wish they were self-employed have not switched to their preferred professional status

- 1 Financial insecurity
- 2 Difficulties with getting financing for the business
- 3 Too much stress, responsibilities or risk
- 4 Less coverage from social protection
- 5 Other reason
- 9 Not applicable (not included in filter conditions)
- Blank (-8) Unknown

## Variables, model questionnaire and explanatory notes for the AHM 2017

### MAINCLNT Col 211

*Number and importance of clients in the last 12 months*

#### Purpose

The variable has two goals: For the respondents who are self-employed without employees it is part of the operational definition of the *economically dependent self-employed*. For the respondents who are self-employed with employees it gives information on the number of clients over the last 12 months, allowing further analysis of the business structure of all self-employed.

If the respondent started working as self-employed less than 12 months before the interview, the meaning of the question is the period of time since their start-up. The results can then be analysed with the help of MSTARTWK [EMNSTRTR] and YSTARTWK [EYRSTRTR] from the core LFS.

#### Notes

All questions refer to main job only.

The starting point for the 12 months is the reference week.

Ongoing work should be included.

‘Income’ should be understood in the same way as INCDECIL.

Because the tests of the model questionnaire clearly showed that it is very difficult to count sources of direct payment, the first question counts the number of clients.

A client is *the person or organization the respondent provided goods and/or services to*. For self-employed who are in a type of business where it would be odd to refer to ‘clients’, for instance farmers, the meaning of the concept can also be explained as ‘customers’.

Question Q1\_Clients, even though it asks for ‘how many clients did you work for’ should be interpreted as ‘how many clients did you, or any of your employees, if you have any, work for’. However, we underline that we only want to measure the work which has been done in a professional capacity in the main job.

For Q1\_Clients, there is no requirement that the respondent has received payment for the service provided yet, only that the work has been done.

The answer option ‘no client in the last 12 months’ is meant to cover for instance new start-ups, who have only been working on acquisitions so far.

Q2\_Clients refers to the amount of income, not the number of jobs for each client, so in an example case as the following, the respondent should say ‘no’:

8 jobs for client number 1 = 1000 €: 25% of income and 80% of work done

1 job for client number 2 = 2000 €: 50% of income and 10% of work done

1 job for client number 3 = 1000 €: 25% of income and 10% of work done

So even though 80% of jobs went to one client the respondent should say ‘no’ here as no one client provides 75% of the income.

Source for the variable: “Self-employed without employees in Finland 2013”. “Self-employed survey 2012”, the Netherlands 2012 (referred to as ZEA). National LFS in IT, FI, UK.



## WORKORG Col 212

### *Influence over deciding working hours*

#### **Purpose**

This variable is the second part of the operational definition of economically dependent self-employed. It is asked if the respondent is self-employed and has had at least one client over the last 12 months. Its main purpose is to find out if the respondent controls his/her own working time, which is a main element in being self-employed. In the same way as the MAINCLNT variable, it can be used to analyse the work organisation for all self-employed who had at least one client in the last 12 months, allowing further analysis of their business structure.

#### **Notes**

“Working hours” are to be understood as ‘start and end of the working day’ not as ‘volume of work’.

As the main purpose is to achieve a clear cut distinction on if it is the respondent or the respondents’ client(s) who decide(s) the working time, the answer options do not offer any middle category, like ‘jointly decided’. If a respondent is in such a situation, we leave it up to her/him to decide on if the influence of the client is so strong that they could not say no to the client’s request for generally adjusting their working time: could the respondent realistically turn down the client’s request for the working time and still keep the contract for the work?

The ‘any other party’ answer option is added to be sure to cover all possibilities, and could for instance be ‘weather’. As we consider elements outside human control to not have any significance on organisational dependency, we will only code those who have Q2\_Workinghours = 1 as economically dependent self-employed.

We have chosen to not split the ‘any other party’ into further sub-divisions, because the main purpose of the variable is to only find dependent self-employed, and we want to keep the response burden down. However, we do not have any objections to doing this nationally, as long as it does not disturb the variable. These must be collapsed in the transcoding for Eurostat data file.

Sources for the variable: Italian national LFS, the survey of self-employed without employees in Finland (2013), the Survey of Self-Employment in Canada (2002). Theoretical background from the Supiot Report, from Boheim/Muhlberger ‘Dependent self-employment: workers between employment and self-employment in the UK’ (2009), from the European Parliament study ‘Social protection rights of economically dependent self-employed workers’ (2013), and from the Eurofound 6<sup>th</sup> European Working Conditions Survey (2015).

## **REASSE Col 213**

*Main reason for becoming self-employed when starting to work as self-employed in the current job*

### **Purpose**

The variable collects what the main reason for becoming self-employed was. It refers to when the respondent started working as self-employed in the current job

### **Notes**

There are three main over-arching categories in the variable: push / pull / coincidental. Codes 1, 2 and 6 are clearly in the ‘became self-employed for involuntary reasons’ category. Codes 3, 7 and 8 are clearly in the voluntary side. Code 4 covers those who more or less stumbled upon becoming self-employed. Code 5 could be any of the push / pull / coincidental, and is therefore best analysed alone.

Answer option 2 is of particular interest in analysing forced self-employment, and will cover the often cited examples of employees who are given the option of either being fired, or to start working self-employed, and then they will be hired back on a private contract basis by their former employer. It should be analysed together with the composite variable of economically dependent self-employment.

As the variable has two ‘other’ values, answer option 6 will cover the rest of the group of push reasons for becoming self-employed, and answer option 8 will cover the pull reasons.

Code 5 does not cover situations of ‘starting a family business’.

For analysis purposes, REASSE together with JOBSATISF will give a picture of the development over time for the self-employed, as it will be possible to see if current levels of job satisfaction are correlated to the reasons for initially becoming self-employed in the current job.

The push / pull part of the variable is inspired by the Survey of Self-Employment in Canada (2002) and the Dutch ZEA. The ‘became self-employed by coincidence’ idea was added from the “Self-employed without employees in Finland 2013”.

The questions for this variable can be asked in two ways: either telling the respondent all answer options in one go, and then asking her/him to choose the main reason, or asking for a yes / no for each of the reasons listed, with a follow-up question on which of the yes-answers was the main reason.

The variable refers to when the respondent started to work in the current job.

## **SEDIFFIC Col 214**

*Self-perceived main difficulty working as self-employed*

### **Purpose**

The variable checks if there are difficulties for the self-employed, and if so, what the main difficulty is.

### **Notes**

If the respondent has worked less than 12 months as self-employed, the period refers to since the respondent started working as self-employed in the current main job.

A possible analytical grouping of the values is 0, 1, 2, 5 and 6 as market based reasons, 3 as state / public sector imposed reason, and 4 as sickness reason.

The questions for this variable can be asked in two ways: either telling the respondent all answer options in one go, and then asking her/him to chose the main reason, or asking for a yes / no for each of the reasons listed, with a follow-up question on which of the yes-answers was the main reason.

“Lack of influence on setting the price of work” means that the market situation forces the respondent to under-price his or her service or product.

"Inappropriate levels of administrative burden" means paper work, bureaucratic requirements, for instance long or complicated processes for registering social insurance for employees, or for filling out the tax forms.

The variable is based on the Survey of Self-Employment in Canada (2002).

### **REASNOEM Col 215**

*Self-perceived main reason for not having employees*

#### **Purpose**

The variable checks what is the main reason why a self-employed without employees works without employees.

#### **Notes**

This variable has four main groupings, sub-divided into seven sub-reasons: Having freely chosen to not have any employees (codes 0 and 6); market condition / economic cycle (codes 1 and 2); rules, or regulations (codes 3, 4 and 5); requirements of the clients (code 7); too expensive (code 4).

Associates (6) can be either co-owners as well as other businesses.

Code 0 covers both those who like to work alone, as well as those who do not want expand their business. We don't look into the detailed reasoning behind the respondent's choice, but it is clearly a voluntary choice, as opposed to limitations coming from the market conditions or regulations.

Code 0 also covers cases where the respondent has freely chosen to work alone, for his or her own reasons. If he/she is afraid that there would not be enough work (which would be an external influence, for instance low demand), that would be covered by answer option 1.

Code 3 covers situations of too much paperwork and red tape, so the respondent could not be bothered to employ anyone.

Code 4 includes payment of national insurance as well as pensions, holiday pay, sick pay and mat/paternity leave.

This variable is instrumental for the policy directorate general of the Commission which has been involved in developing this module (DG EMPL), in its analysis for how to better support job creation through self-employment and entrepreneurship. It is made by the task force.

Answers along the line of ‘too expensive to pay wages’ should be coded as ‘There is not enough work’.

If the main reason is costs, ask the respondent split it on whether it is due to not being able to pay wages due to ‘not enough work’ (code 1) or payment of ‘social contribution’ (code 4). If the respondent cannot manage to split it, it should be coded as ‘1’.

The questions for this variables can be asked in two ways: either telling the respondent all answer options in one go, and then asking her/him to choose the main reason, or asking for a yes/no for each of the reasons listed, with a follow-up question on which of the yes-answers was the main reason.

### **BPARTNER Col 216**

*Working with a co-owner and/or in a network of other self-employed*

#### **Purpose**

The variable aims to capture if self-employed work together with formal or informal business partners, where there is no relationship of subordination among them as opposed to having employees. It therefore gives a more detailed picture of the business structure than just STAPRO [ESTATR].

#### **Notes**

Business partners are formal co-owners, that is, other persons who have a financial stake in the business, and who have a say in top level decisions. In short: another person who shares the risks and the profits of the company.

A network is a non-hierarchical group of persons who have regular professional contact, in order to share work, and who mutually benefit from cooperation. An example could be a plumber who takes renovation contracts for private homes, and has a long standing agreement with an electrician and a carpenter who s/he can contract in case the renovation needs this type of work as well.

Given that cooperatives are formal forms of collective actions, which are jointly owned and require some investment of capital and/or goods, members of cooperatives would be expected to answer that they work together with a co-owners.

The general idea of networks and business partners comes from the Survey of Self-Employment in Canada (2002). It was changed to ‘co-owners and network’ based on the tests of this model questionnaire.

The question refers to the respondents’ current situation.

## **PLANEMPL Col 217**

*Plans to employ or sub-contract in the next 12 months*

### **Purpose**

The variable checks if the respondent plans to hire employees or to subcontract work.

### **Notes**

In the interest of having as simple filters and questionnaire routing as possible (which has been a major issue for many previous ad hoc modules), we have not made any special solutions in this variable for those who answered REASNOEM = 5 (does not have any employees because this is not possible in their profession). We would assume that these will answer 'does not plan to hire or subcontract' here.

Hiring from a temporary employment agency would be 'plans to employ temporary employees'.

The respondent is free to decide on whether hiring/working with a freelancer would be a temporary employee or a subcontractor.

"Do you plan to employ someone in the next 12 months?" should cover all situations, so it would include both new staff as well as replacing someone who retires.

"(3) Yes, both" means at least one permanent employee and at least one temporary employee.

Cases of "I plan to hire, but I don't know what type" should be coded as "plans to employ only temporary employees".

The source of this variable is the Dutch ZEA.

## **JBSATISF Col 218**

*The level of job satisfaction in the main job*

### **Purpose**

This variable provides information on how satisfied employees, self-employed and family workers are with their working situation, in order to compare them to each other. It asks about the general level of satisfaction, not individually about working conditions, pay, and so on.

## **AUTONOMY Col 219**

*The level of influence over content and order of tasks in the main job*

### **Purpose**

The variable aims to measure the respondents' influence over own daily work, on the level of content and order of tasks. The variable is the same as in the AHM 2015/2019, but with a simplification of the question wording.

### **Notes**

The order of tasks means how free the respondent is to manage a project. Is the workflow decided by the respondent, or by the respondent's customer/employer?

Influence over the content of tasks asks the respondent if he or she can refuse to take tasks or contracts that he or she does not want to do.

## **PREFSTAP Col 220**

*Preference to work as an employee if currently self-employed, or preference to work as self-employed if currently working as an employee.*

### **Purpose**

To see if respondents would rather work in another STAPRO [ESTATR] category.

### **Notes**

This variable is measuring a general attitude and willingness to change STAPRO, not a concrete and situational wish, like 'anything else kept equal, would you want to be self-employed'. This is because a change in STAPRO will in many cases influence salary. It is unrealistic to expect both more flexibility and to keep the pay level of an employee.

The variable focuses on the shift towards becoming self-employed, so it does not have a code for family workers who wish to become employees.

In case of family workers who want to be an employee rather than self-employed: Please ask them to prioritise *only* among the answer options, so the question should be interpreted as 'if you could choose among continuing to be a family worker or start being a self-employed: which one of these two would you choose?'

The idea for this variable is based on the Dutch ZEA and the survey "Self-employed with employees in Finland 2013".

## **OBSTACSE Col 221**

*The main reason why current employees or family workers who wish they were self-employed have not switched to their preferred professional status*

### **Purpose**

The purpose is to know what is keeping employees and family workers from changing to being self-employed, if they have said that they would like to be self-employed.

### **Notes**

Answer option 1 covers cases of not having a fixed salary, but rather being dependent on the business cycle and your ability to promote your own business.

Answer option 4 means to have no paid holidays, no guarantee of income in case of illness, no pension from an employer, and no paid mat/paternity leave.

Respondents who already started the process of becoming self-employed (currently they are fixing the formalities) should be coded "5, other reason".

**Specifications of the 2016 ad hoc module on young people on the labour market**

Column	Code	Description	Filters/remarks
		<b>SUB-MODULE: EDUCATIONAL BACKGROUND</b>	AGE = 15 - 34
211	WORKEXP	<b>Work experience during studies</b> <i>Paid or unpaid work experience during the highest level of education</i> 1 (HATLEVEL) 2 Both paid and unpaid work experience 3 Paid work experience only 4 Unpaid work experience only 9 No work experience during HATLEVEL Blank Not applicable (not included in filter) Unknown	HATLEVEL ≠ 000
212	WORKSTUD	<b>Work-based learning</b> <i>Type of work experience that is part of the curriculum of the highest Level of education (HATLEVEL)</i> 1 Apprenticeship (operational Eurostat definition) 2 Mandatory traineeship 3 Mandatory work-based training where distinction between 1 and 2 is not possible. 4 Optional traineeship (part of education) 5 Work outside the curriculum 9 Not applicable (not included in filter) Blank Unknown	WORKEXP = 1 – 3
213/214	ADDLEVEL	<b>Level of additional formal education</b> <i>Level and orientation of formal education that person started after reaching highest level of education</i> 00 No formal education started after reaching the highest level of education 10 ISCED 1 20 ISCED 2 30 ISCED 3 where distinction by orientation is not possible 34 ISCED 3 general programme 35 ISCED 3 vocational programme 40 ISCED 4 where distinction by orientation is not possible 44 ISCED 4 general programme 45 ISCED 4 vocational programme 50 ISCED 5 60 ISCED 6 70 ISCED 7 80 ISCED 8 99 Not applicable (not included in filter) Blank Unknown	EDUCSTAT = 2



**Specifications of the 2016 ad hoc module on young people on the labour market, cont'd**

Column	Code	Description	Filters/remarks
215	DROPREAS	<b>Reason for dropping out</b> <i>Main reason for not completing the level of formal education started</i> 0 Completed last formal education Did not complete last formal education due to: 1 The level of difficulty 2 Failure of study to meet needs or interest 3 The costs of studying 4 A wish to start working 5 Family reasons 6 Health reasons 7 Other 9 Not applicable (not included in filter) Blank Unknown	EDUCSTAT = 2 and ADDLEVEL ≠ 00
216/221	LEAVDATE	<b>Date of leaving formal education</b> <i>Year and month of leaving formal education</i> Enter the four digits of the year concerned 9999 Not applicable (not included in filter) Blank Unknown (year)  Enter the two digits of the month concerned 99 Not applicable (not included in filter) Blank Unknown (month)	EDUCSTAT = 2 and ADDLEVEL ≠ 00
222	NCONREAS	<b>Reason for not continuing education</b> <i>Main reason for not continuing formal education</i> 0 Highest level of education was considered high enough 1 The level of difficulty 2 Failure of study to meet needs or interest 3 The costs of studying 4 A wish to start working 5 Family reasons 6 Health reasons 7 Other 9 Not applicable (not included in filter) Blank Unknown	EDUCSTAT = 2 and ADDLEVEL = 00 and HATLEVEL = 000 – 500

## Specifications of the 2016 ad hoc module on young people on the labour market, cont'd

Column	Code	Description	Filters/remarks
		<b>SUB-MODULE: FINDING A JOB</b>	AGE = 15 - 34
223	SUPPORT	<b>Support received for finding work</b> <i>Most helpful type of support for finding a job received from public Agencies during the previous 12 months</i>	(WSTATOR = 1, 2 and STARTIME < 12) or WSTATOR = 3 - 5
	0	No support received	
		Most helpful type of support:	
	1	Assistance in finding job vacancies	
	2	Advice on how to apply for a job	
	3	Advice on opportunities for training and education	
	4	Being given a place on a work programme	
	5	Being given a place on an educational or training programme	
	6	Other	
	7	Support received, but not considered helpful	
	8	Support received, but level of helpfulness unknown	
	9	Not applicable (not included in filter)	
	Blank	Unknown	
224	FINDMETH	<b>Method of finding current job</b> <i>Method used to find current main job</i>	STAPRO = 3
	1	Advertisements, via any channel	
	2	Relatives, friends or acquaintances	
	3	Public employment office	
	4	Private employment agency	
	5	Education or training provider	
	6	Contacted employer directly	
	7	Employer contacted person directly	
	8	Other	
	9	Not applicable (not included in filter)	
	Blank	Unknown	
225	OKLEVEL	<b>Appropriateness of job given the respondent's level of education</b> <i>Extent to which the respondent's current main job corresponds to their level of education</i>	WSTATOR = 1, 2
	1	The job corresponds well to their education	
	2	The job corresponds to some extent to their education	
	3	The job does not correspond very well to their education	
	4	The job does not correspond at all to their education	
	9	Not applicable (not included in filter)	
	Blank	Unknown	

**Specifications of the 2016 ad hoc module on young people on the labour market, cont'd**

Column	Code	Description	Filters/remarks
226	MOVE4JOB	<p><b>Willingness to move for job</b>  <i>Willingness to change place of residence for a job</i>                      Respondent has moved or would be willing to move within their country</p> <p>1</p> <p>2 Respondent has moved or would be willing to move to another EU country</p> <p>3 Respondent has moved or would be willing to move outside the EU</p> <p>4 Respondent has not moved or would not be willing to move for a job</p> <p>Blank Unknown</p>	
227	CMT4JOB	<p><b>Willingness to commute for job</b>  <i>Willingness to have a long commute for a job</i>                      Respondent is currently commuting or would be willing to commute for longer than one hour (each direction)</p> <p>Respondent is not currently commuting and would not be willing to commute for longer than one hour (each direction)</p>	

WORKEXP : Paid or unpaid work experience during the highest level of education  
(Eurostat AHM 2016 Col 211)

Start date: Jan 2016  
End date: Dec 2016

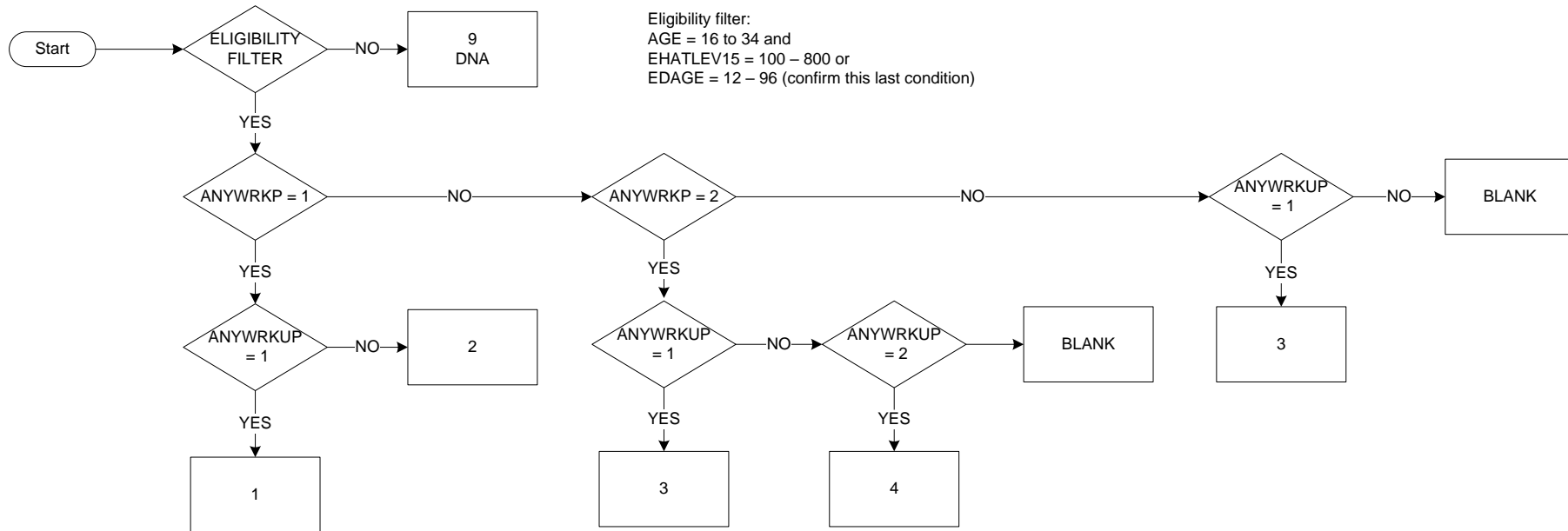

Eligibility filter:  
AGE = 16 to 34 and  
EHATLEV15 = 100 – 800 or  
EDAGE = 12 – 96 (confirm this last condition)

Key:  
1 Both paid and unpaid work experience  
2 Paid work experience only  
3 Unpaid work experience only  
4 No work experience during EHATLEV15  
9 Not applicable (not included in filter condition)  
Blank (-8) Unknown

WORKSTUD : Type of work experience that is part of the curriculum of the highest level of education  
(Eurostat AHM 2016 Col 212)

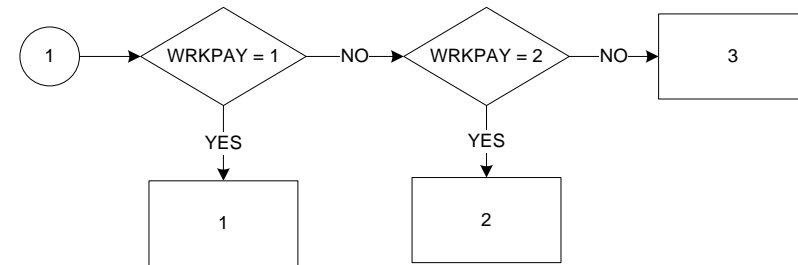
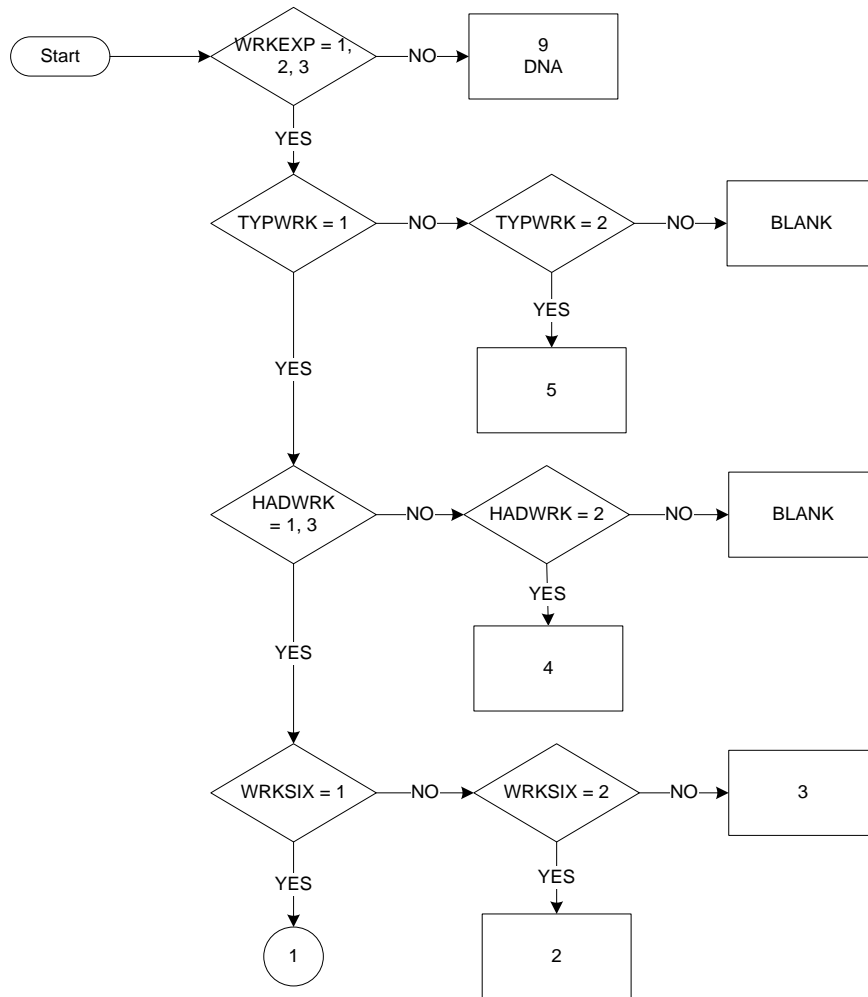

Key:  
 1 Apprenticeship  
 2 Mandatory traineeship  
 3 Mandatory work-based training where distinction between 1 and 2 is not possible  
 4 Optional traineeship  
 5 Work outside the curriculum  
 9 Not applicable (not included in filter conditions)  
 Blank (-8) Unknown

ADDLEVEL : Level and orientation of formal education that a person started after reaching their highest level of education  
(Eurostat AHM 2016 Col 213 - 214)

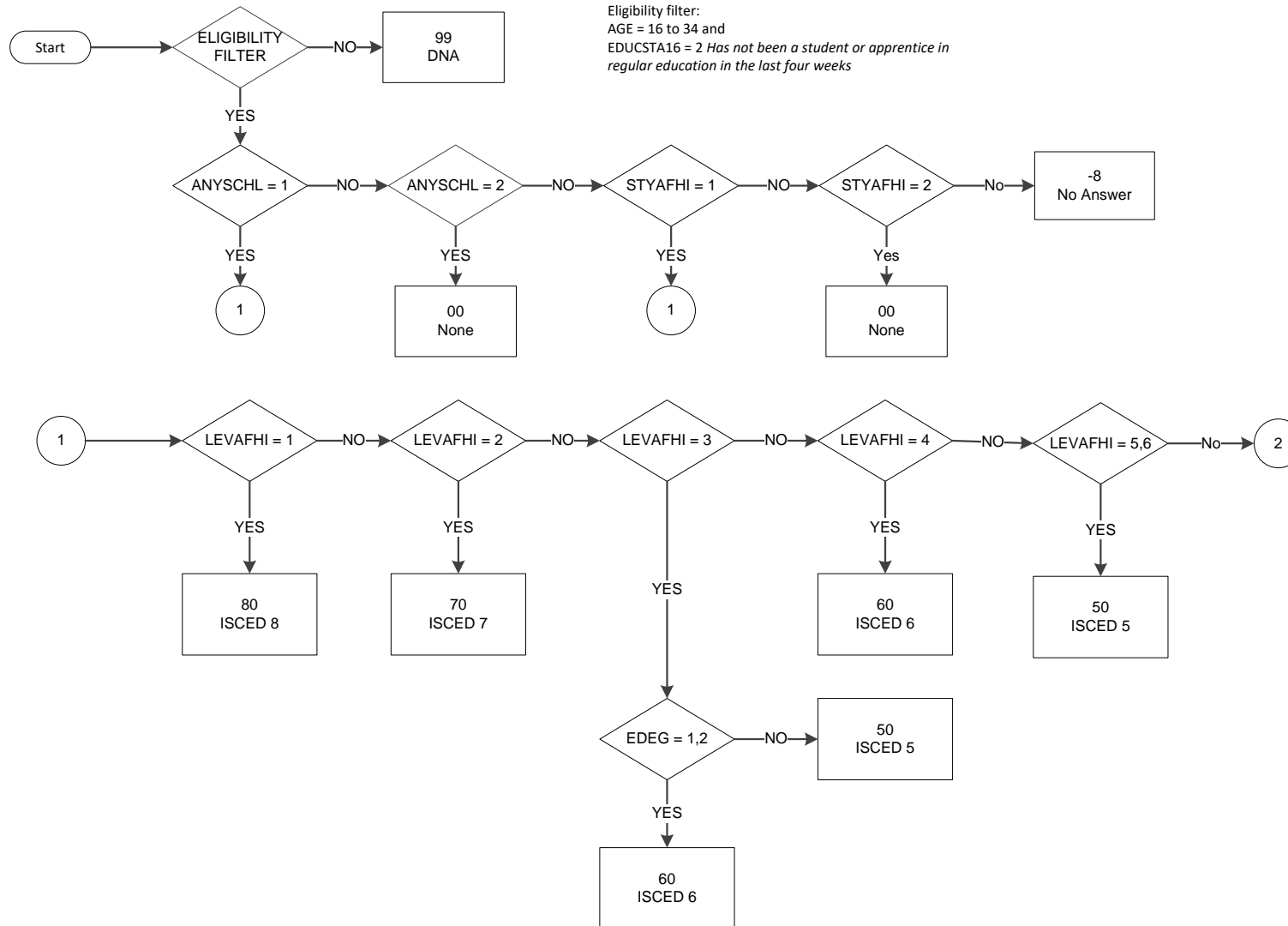

ADDLEVEL : Level and orientation of formal education that a person started after reaching their highest level of education  
(Eurostat AHM 2016 Col 213 - 214)

Start date: Jan 2016  
End date: Dec 2016

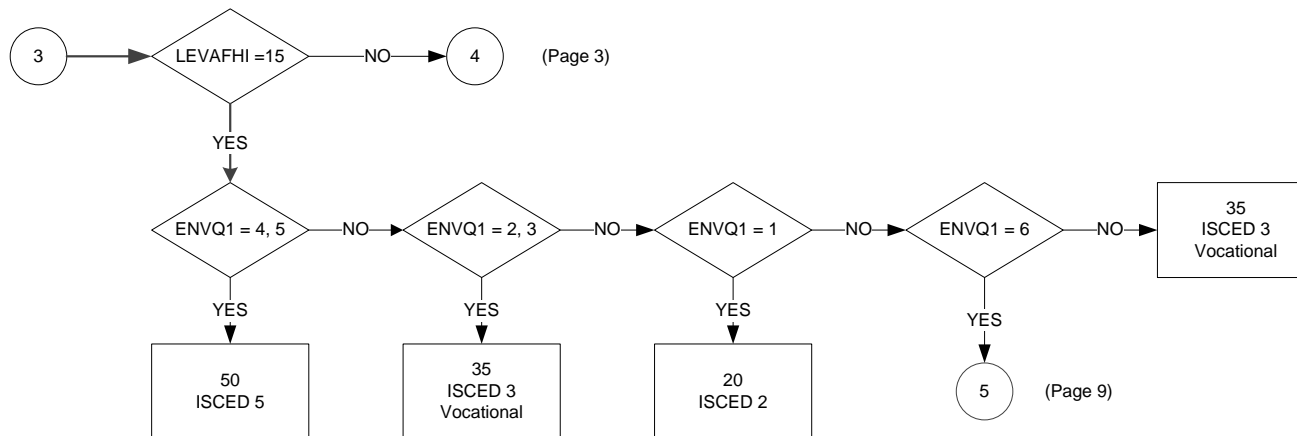
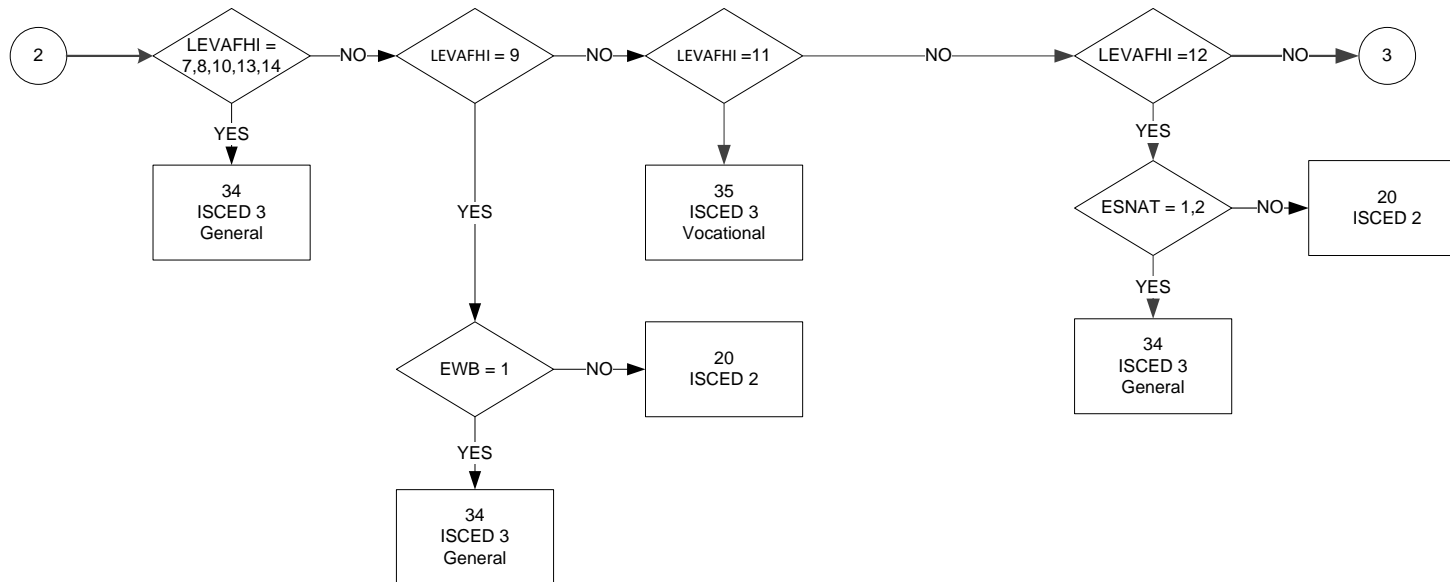

Key	
00	No other formal education started after reaching the highest level of education
10	ISCED 1
20	ISCED 2
30	ISCED 3 where distinction by orientation is not possible
34	ISCED 3 general programme
35	ISCED 3 Vocational programme
40	ISCED 4 where distinction by orientation is not possible
44	ISCED 3 general programme
45	ISCED 3 Vocational programme
50	ISCED 5
60	ISCED 6
70	ISCED 7
80	ISCED 8
99	not applicable

ADDLEVEL : Level and orientation of formal education that a person started after reaching their highest level of education  
(Eurostat AHM 2016 Col 213 - 214)

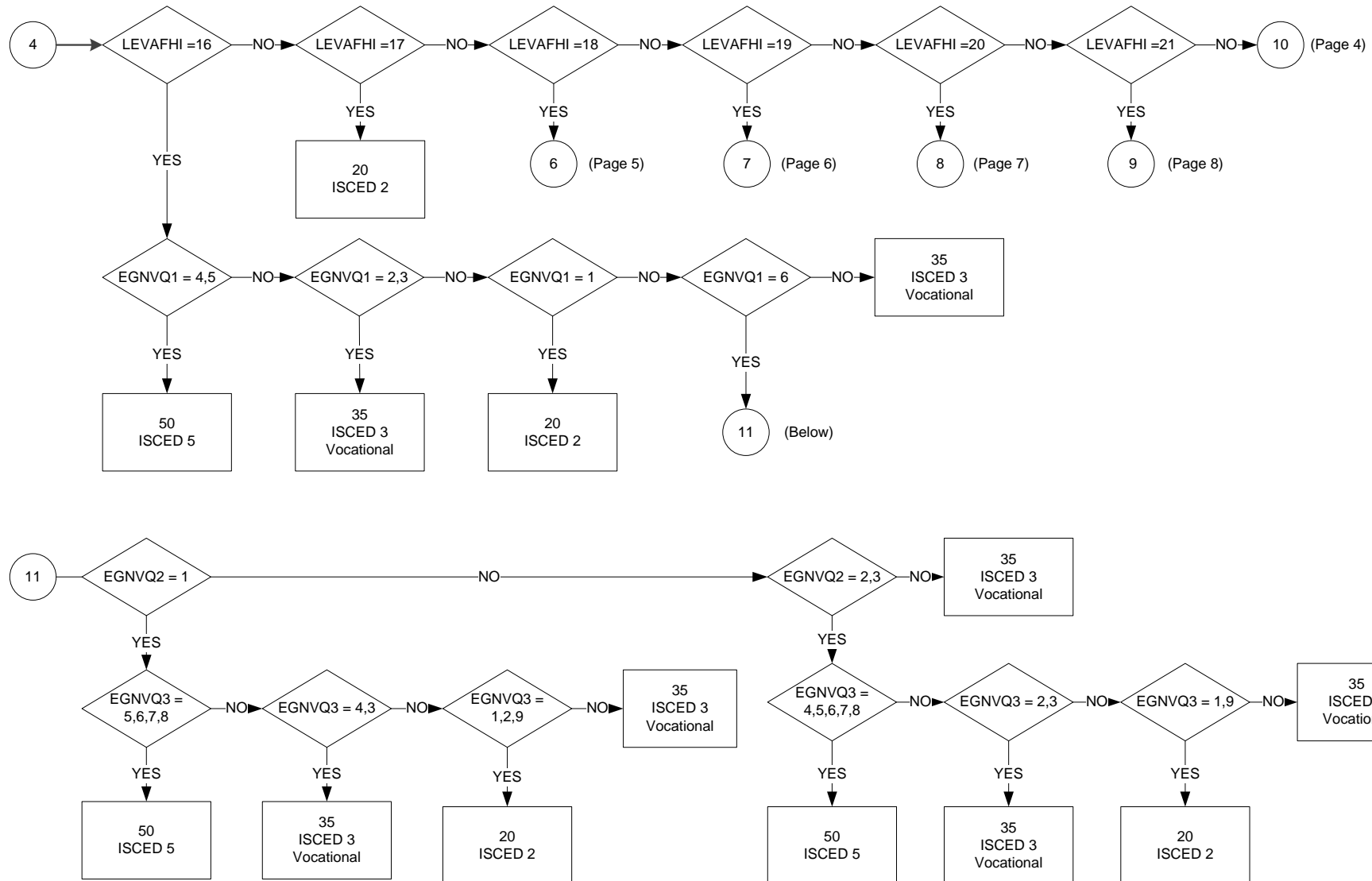



ADDLEVEL : Level and orientation of formal education that a person started after reaching their highest level of education  
(Eurostat AHM 2016 Col 213 - 214)

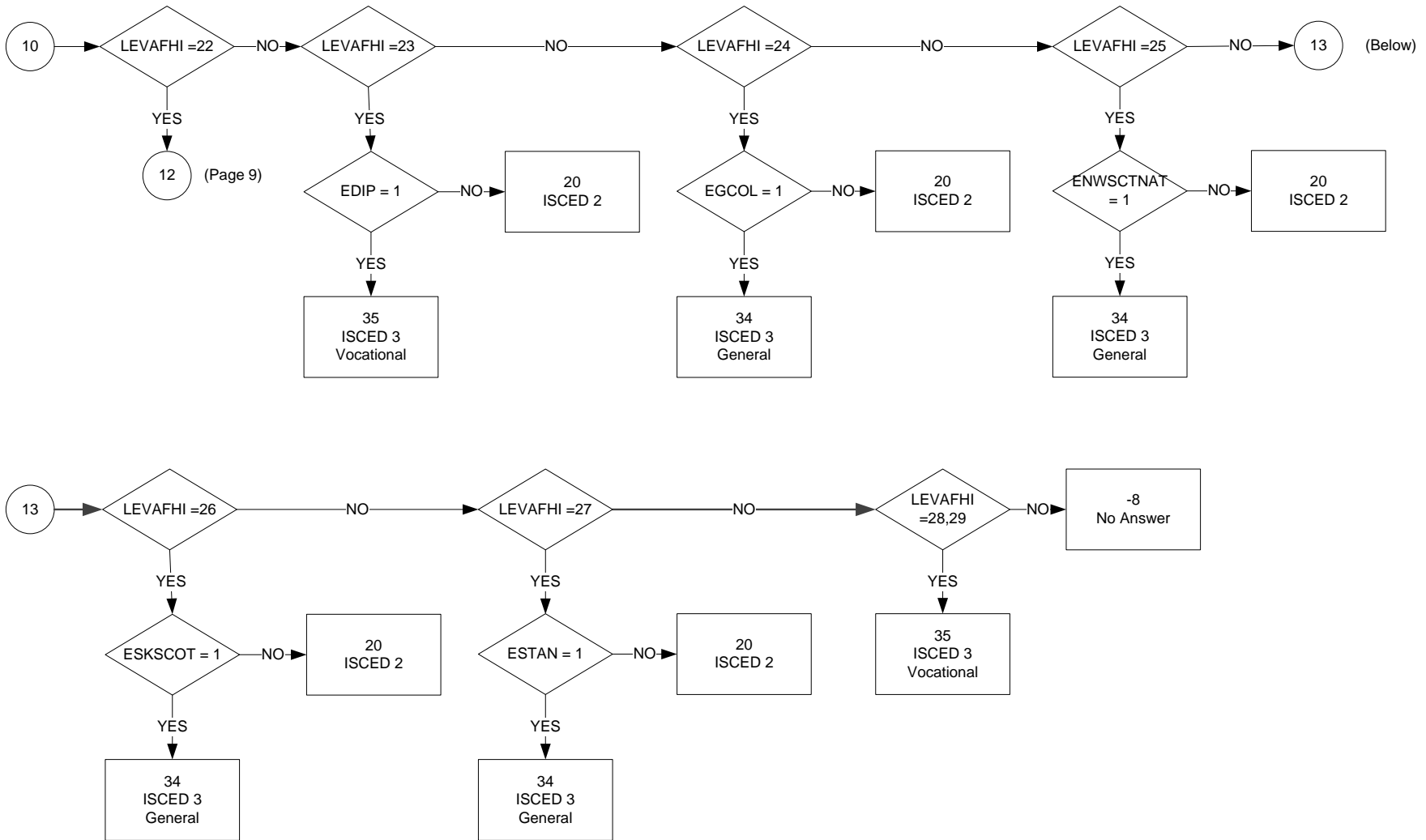

ADDLEVEL : Level and orientation of formal education that a person started after reaching their highest level of education  
 (Eurostat AHM 2016 Col 213 - 214)

Page 5 of 9  
 Start date: Jan 2016  
 End date: Dec 2016

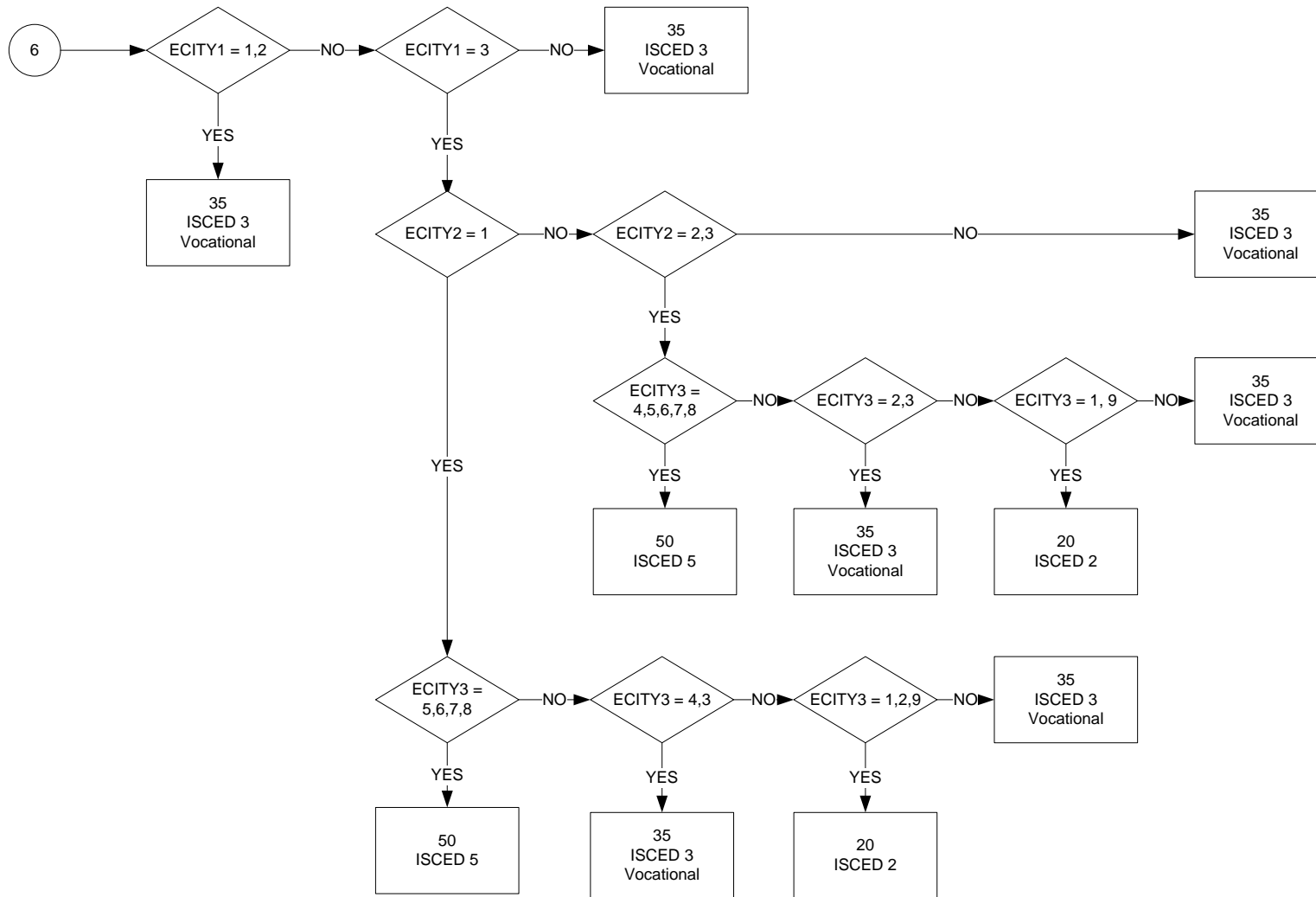

ADDLEVEL : Level and orientation of formal education that a person started after reaching their highest level of education  
 (Eurostat AHM 2016 Col 213 - 214)

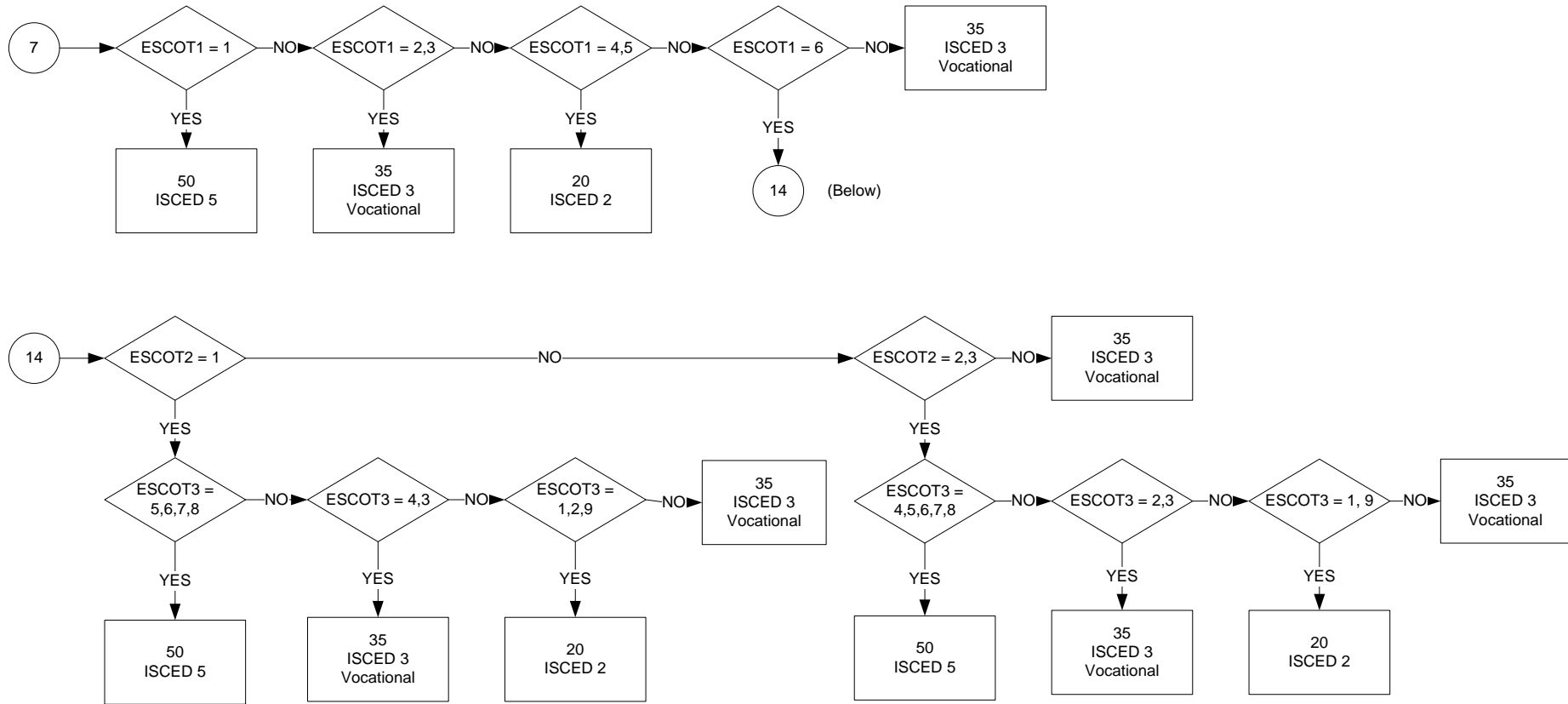

ADDLEVEL : Level and orientation of formal education that a person started after reaching their highest level of education  
 (Eurostat AHM 2016 Col 213 - 214)

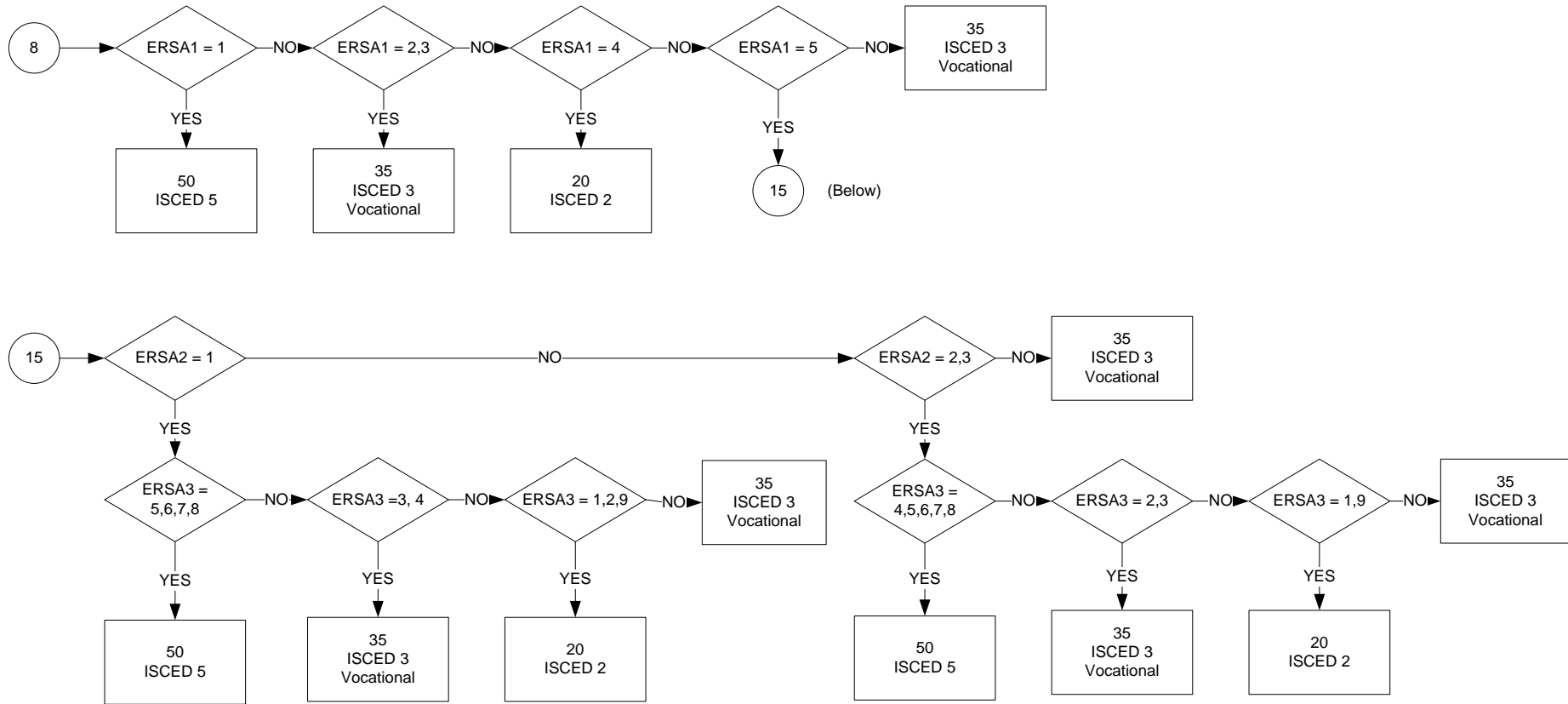

ADDLEVEL : Level and orientation of formal education that a person started after reaching their highest level of education  
(Eurostat AHM 2016 Col 213 - 214)

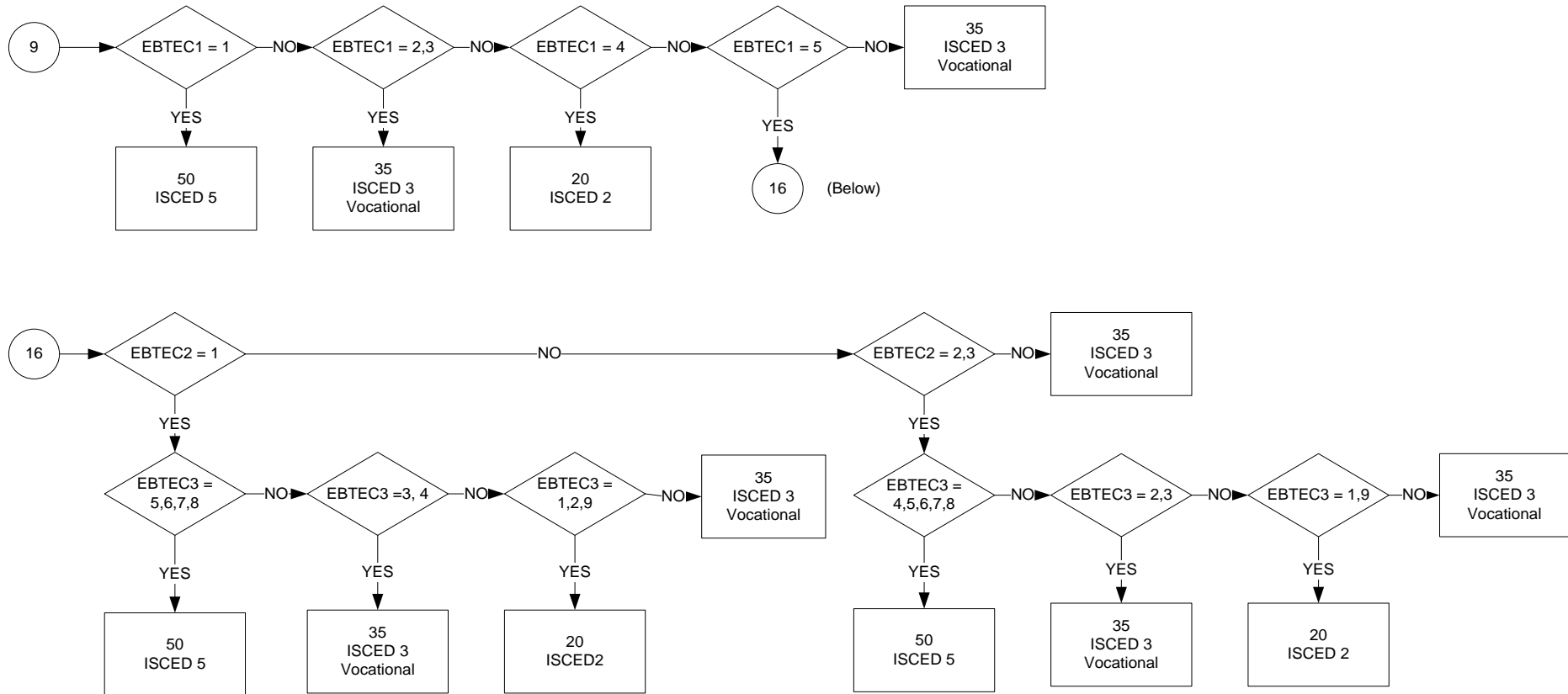

ADDLEVEL : Level and orientation of formal education that a person started after reaching their highest level of education  
 (Eurostat AHM 2016 Col 213 - 214)

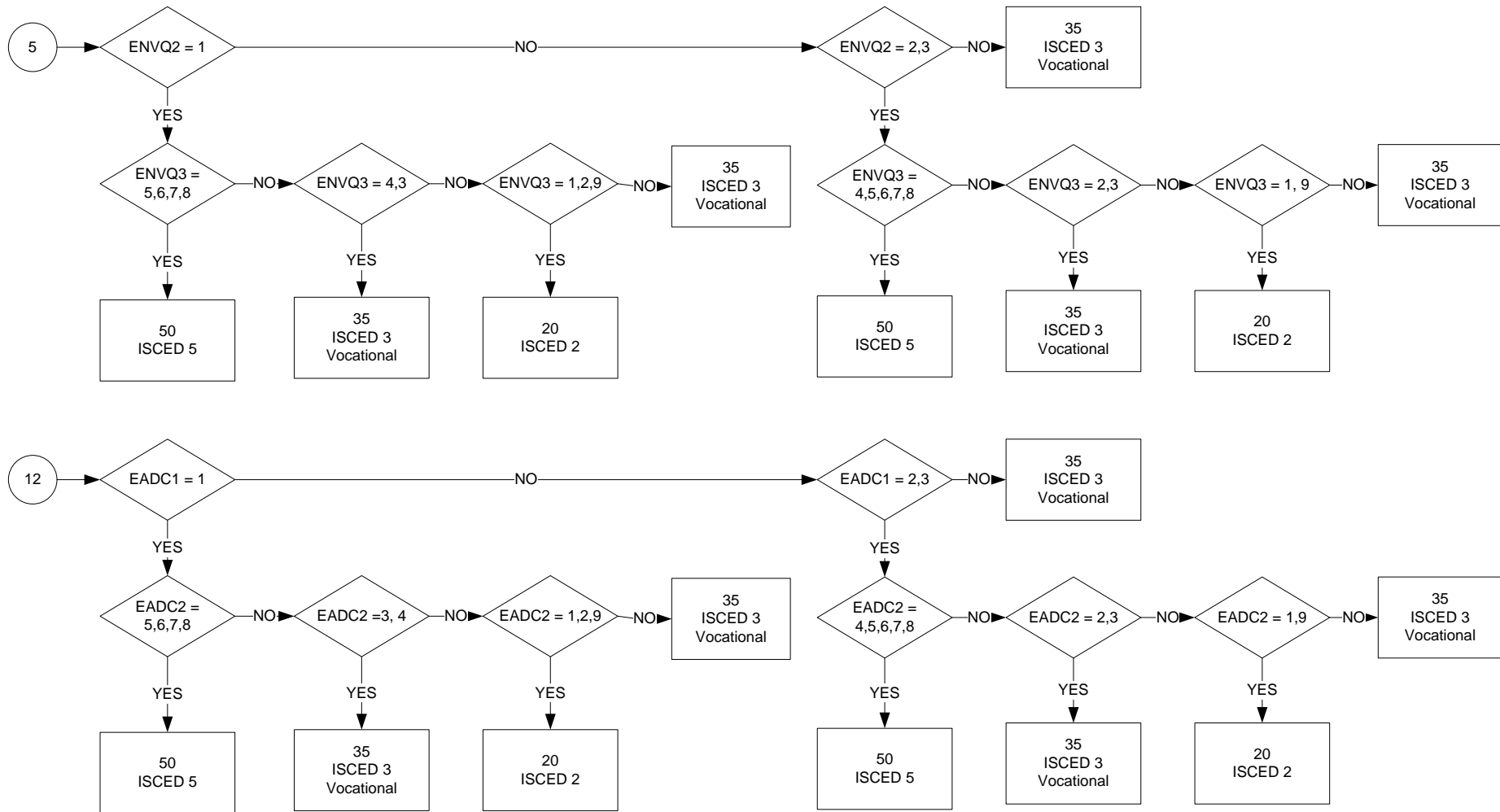

DROPREAS : Main reason for not completing last level of formal education started after completing the highest education  
(Eurostat AHM 2016 Col 215)

Start date: Jan 2016  
End date: Dec 2016

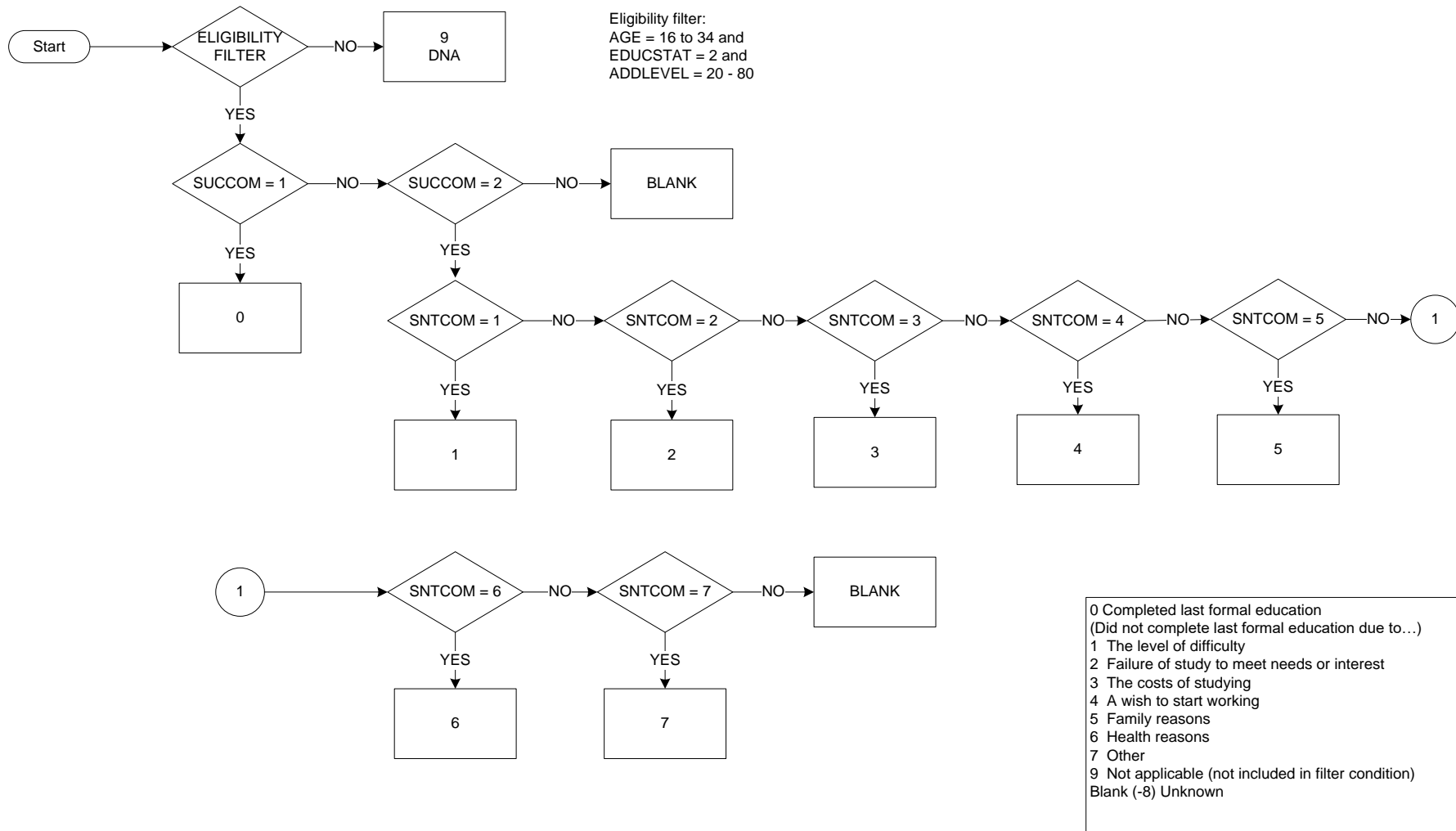

LEAVDATE : Year and month of leaving formal education  
 (Eurostat AHM 2016 Col 216-221)

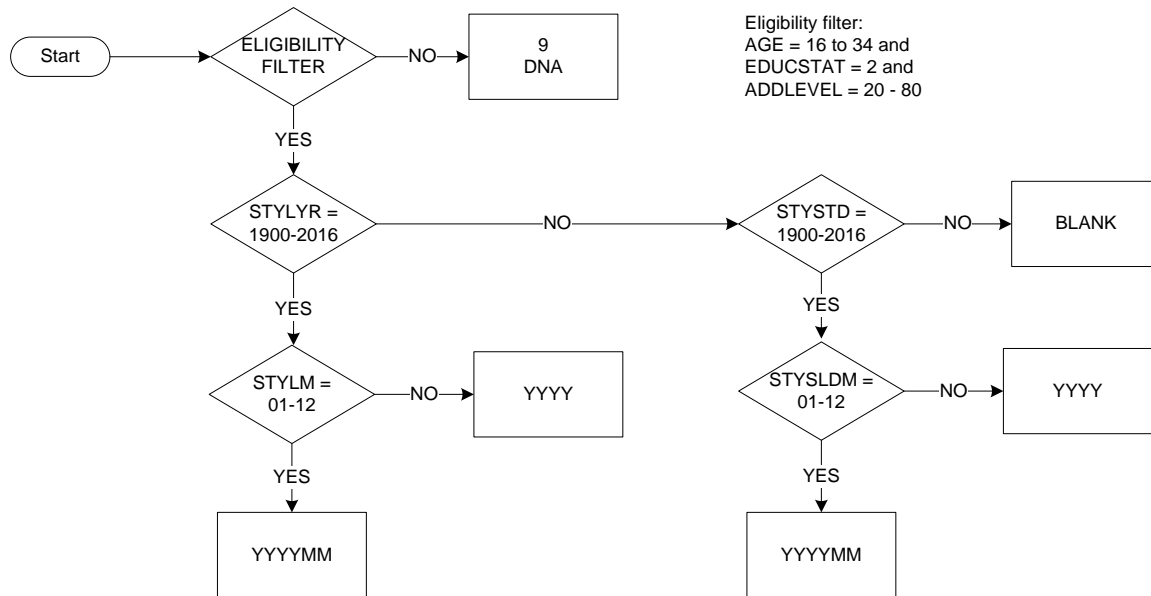



NCONREAS : Main reason for not continuing last formal education  
(Eurostat AHM 2016 Col 222)

Start date: Jan 2016  
End date: Dec 2016

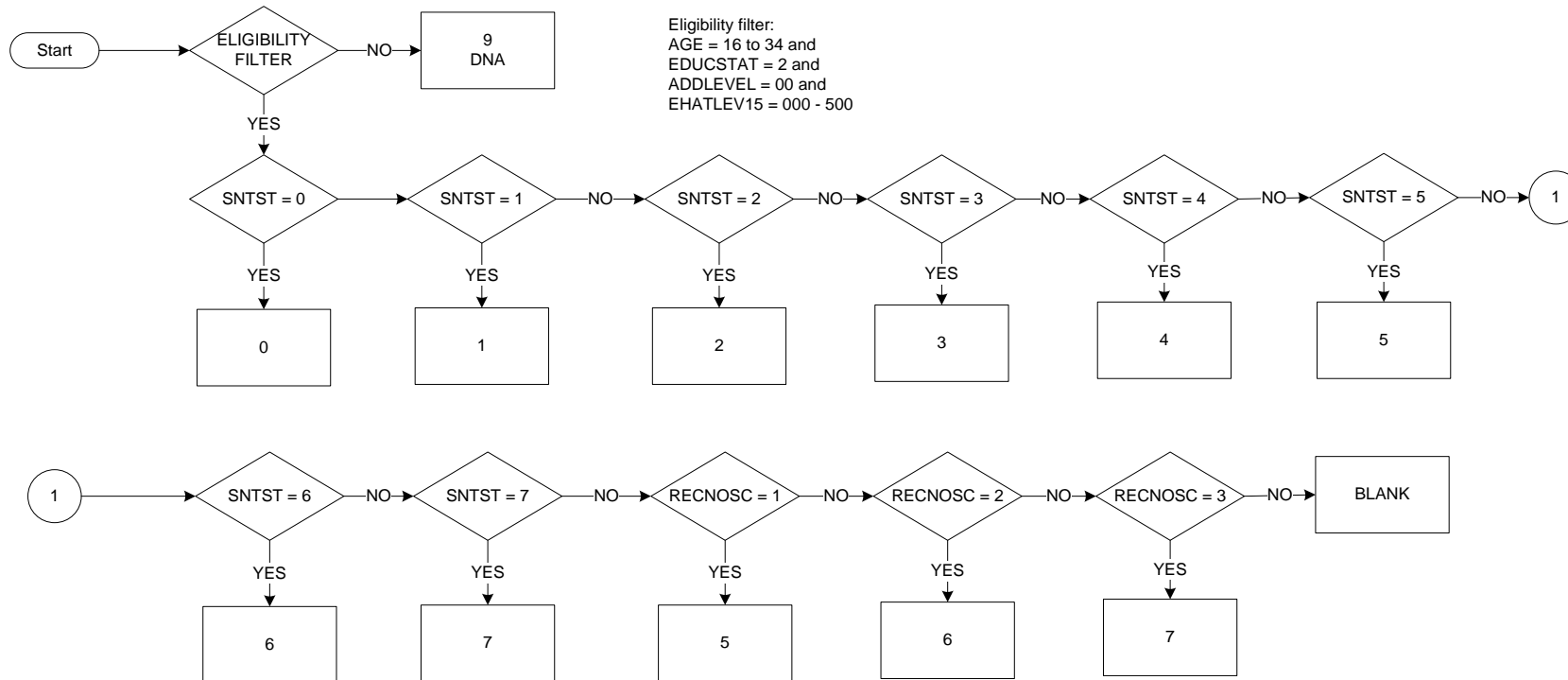

Eligibility filter:  
AGE = 16 to 34 and  
EDUCSTAT = 2 and  
ADDLEVEL = 00 and  
EHATLEV15 = 000 - 500

- Key
- 0 Highest level of education considered high enough
  - 1 The level of difficulty
  - 2 Failure of study to meet needs or interest
  - 3 The costs of studying
  - 4 A wish to start working
  - 5 Family reasons
  - 6 Health reasons
  - 7 Other
  - 9 Not applicable (not included in filter condition)
  - Blank (-8) Unknown

SUPPORT : Most helpful type of support for finding a job received from public agencies during previous 12 months  
(Eurostat AHM 2016 Col 223)

Start date: Jan 2016  
End date: Dec 2016

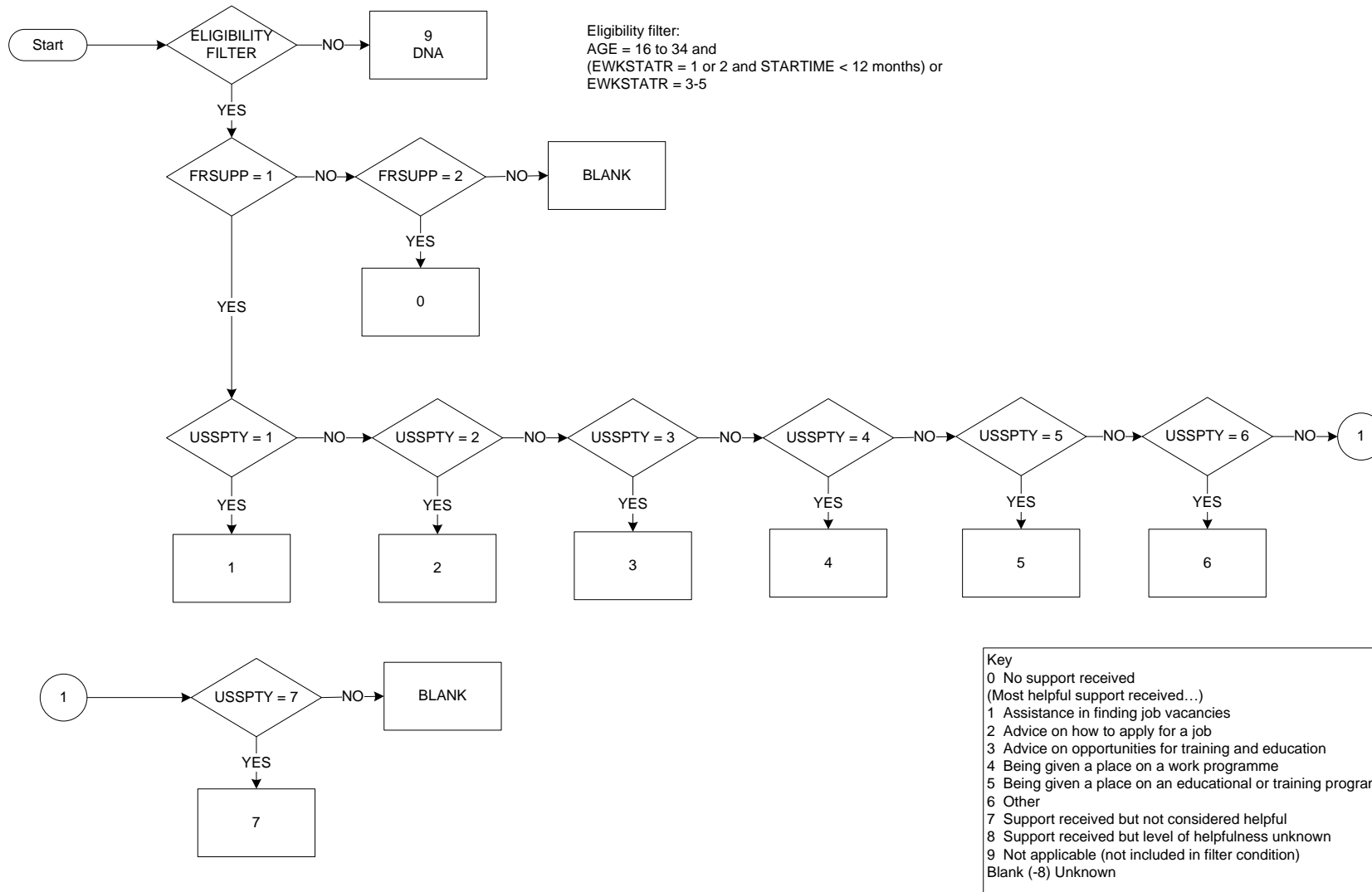

FINDMETH : Method used to find current main job  
(Eurostat AHM 2016 Col 224)

Start date: Jan 2016  
End date: Dec 2016

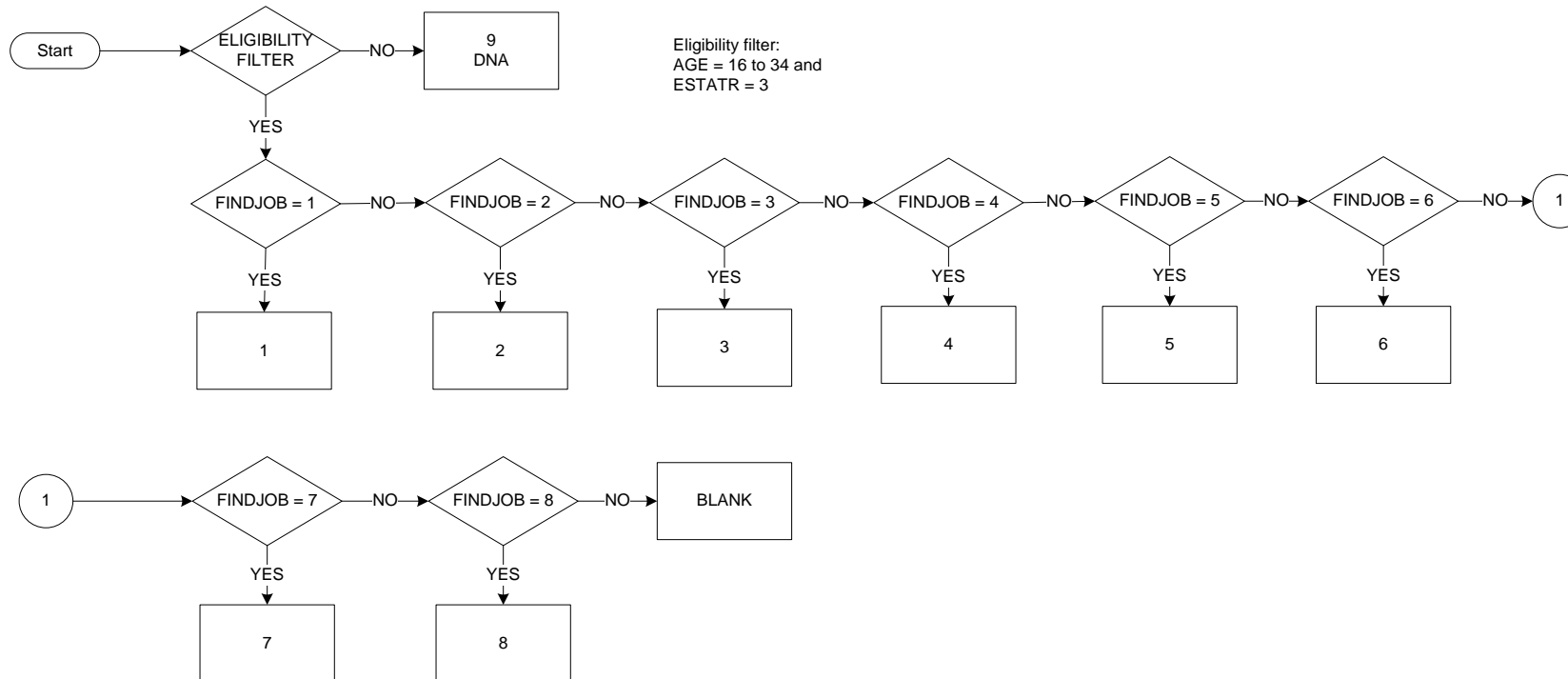

- Key
- 1 Advertisements, via any channel
  - 2 Relatives, friends or acquaintances
  - 3 Job centre
  - 4 Private employment agency
  - 5 Education or training provider
  - 6 Contacted employer directly
  - 7 Employer contacted person directly
  - 8 Other method
  - 9 Not applicable (not included in filter condition)
  - Blank (-8) Unknown

OKLEVEL : Extent to which respondent's current main job corresponds to their level of education  
(Eurostat AHM 2016 Col 225)

Start date: Jan 2016  
End date: Dec 2016

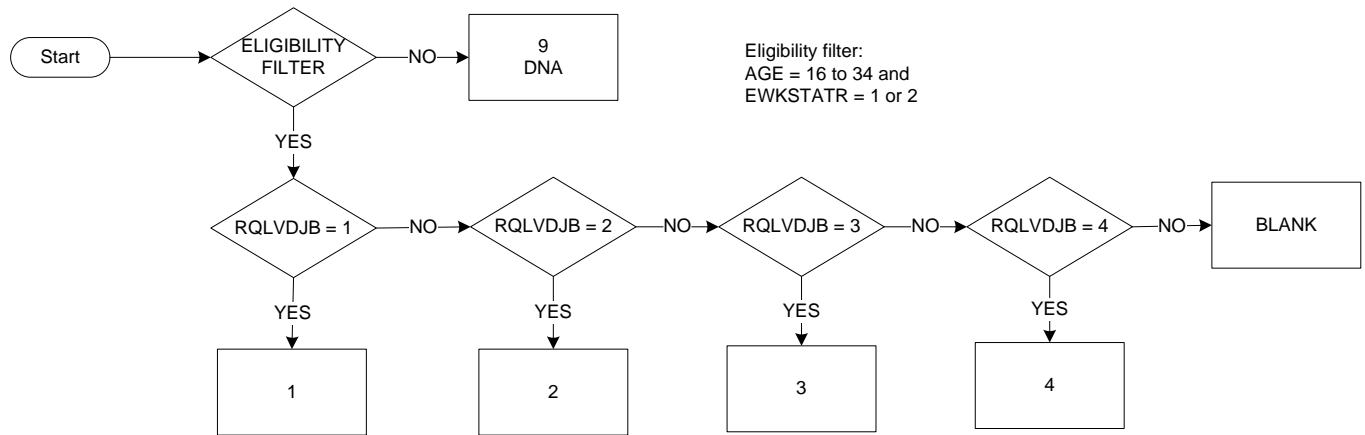

Key  
 1 Job corresponds well to level of education  
 2 Job corresponds to some extent to level of education  
 3 Job does not correspond very well to level of education  
 4 Job does not correspond at all to level of education  
 9 Not applicable (not included in filter condition)  
 Blank (-8) Unknown

MOVE4JOB : Willingness to change place of residence for a job  
(Eurostat AHM 2016 Col 226)

Start date: Jan 2016  
End date: Dec 2016

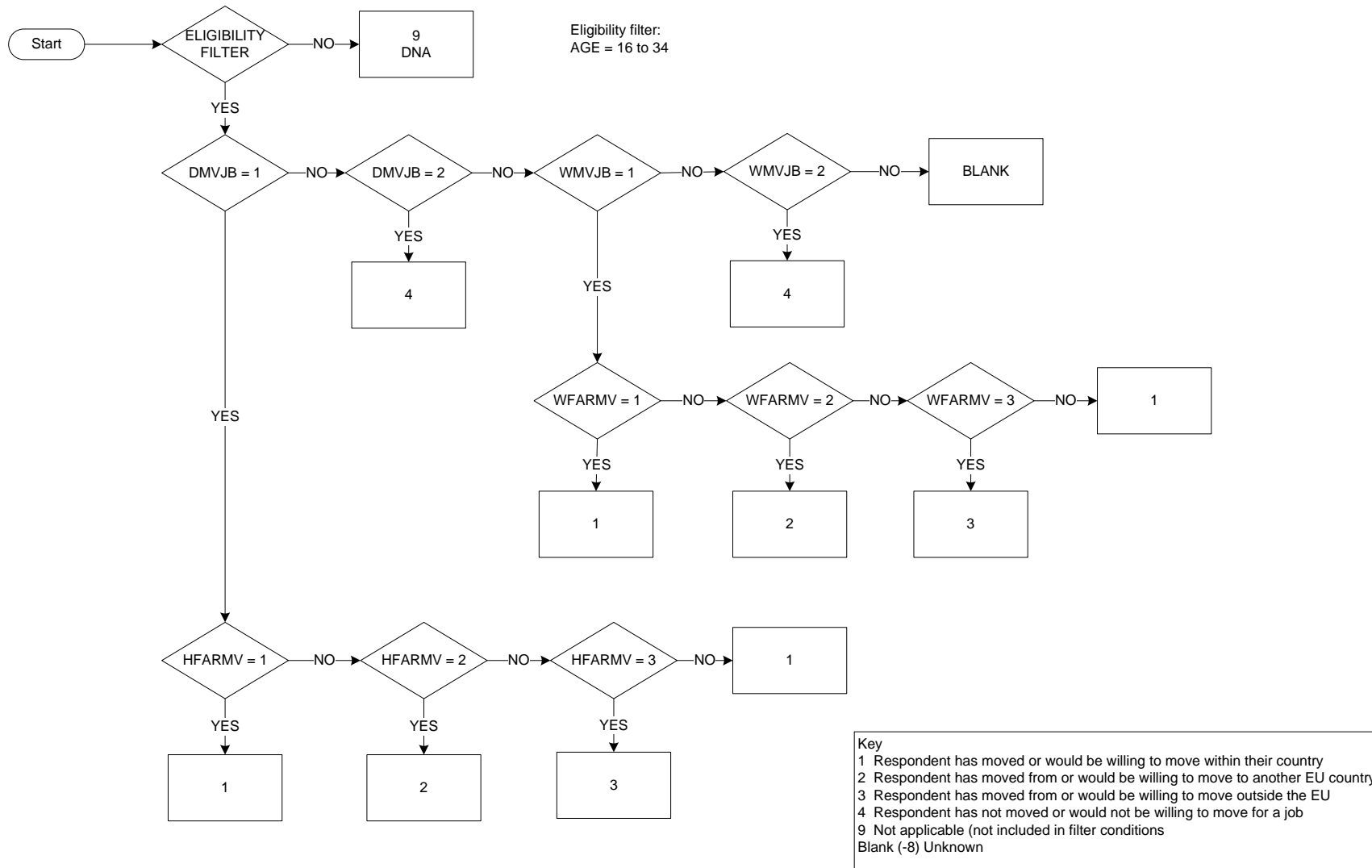

CMT4JOB : Willingness to have a long commute for a job  
(Eurostat AHM 2016 Col 227)

Start date: Jan 2016  
End date: Dec 2016

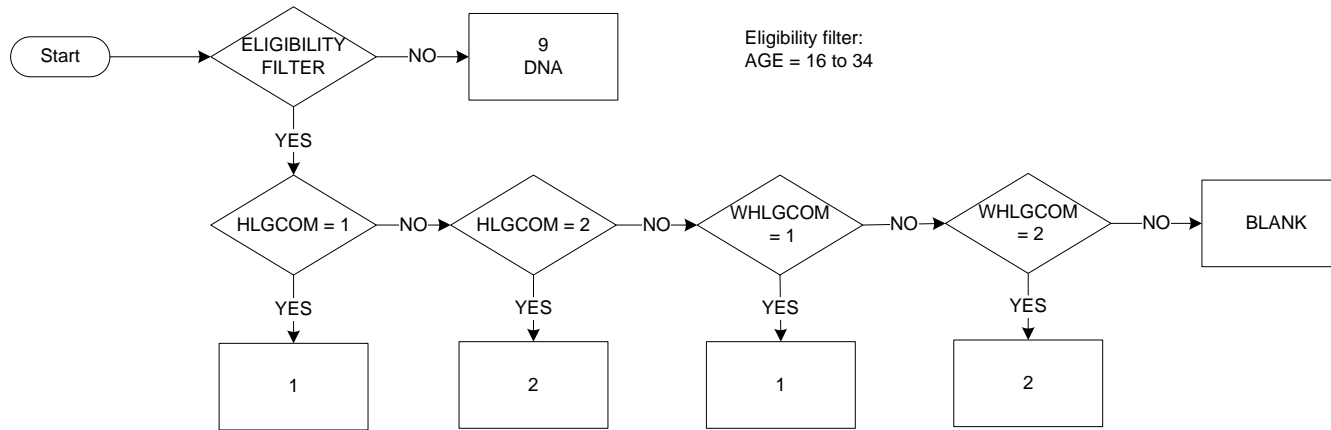

Key  
 1 Respondent is currently commuting or would be willing to commute for longer than one hour (each direction)  
 2 Respondent is not currently commuting and would not be willing to commute for longer than one hour (each direction)  
 9 Not applicable (not included in filter conditions)  
 Blank (-8) Unknown

## Variables, model questionnaire and explanatory notes for the AHM 2016

Introductory text for all respondents: *The following questions are relevant for the young people, collecting extra information on their educational path and the process of finding a job*

### WORKEXP Col 211

Work experience during studies

#### Purpose

The variable aims to capture if the highest level of completed formal education (HATLEVEL) included any practical work experience, with two separate questions for the paid and unpaid work. It was considered important to check that the student had a real contact with the labour market.

Work experience can be part of the curriculum or not, or can have a relation to the content of the highest educational programme completed or not - as shown in the given examples. The variable will be used as filter to further identify work-based learning included in the curricula (WORKSTUD).

The target group of the variable consists of all persons who have at least ISCED 1 as educational attainment level.

#### Notes

For countries where the translation of ‘doing work’ is problematic, ‘having working experience’ can be used as an option to collect the information

- the list of examples can be completed with names of national schemes, in order to help respondents to include periods of work that are integral part of educational programmes (for example the German system of dual apprenticeship)
- for the purpose of this variable, unpaid work is defined as the work performed as apprentice or as trainee and not paid (even if some costs are reimbursed); as voluntary for charity; or when working in a family business or on a family farm. Work even for as little as one hour is included in this definition
- for the purpose of this variable, the whole period of an education cycle (several school years) is considered, starting at the beginning of the first school year which is part of HATLEVEL; work activities taking place during the respective school holidays (for example in a side-job) are considered as work experience acquired during the HATLEVEL period; however, specialisations acquired after receiving the HATLEVEL diploma (in the case of conditioned access to certain professions – like lawyers) are not included for the purpose of this variable
- having some costs reimbursed during the work experience as trainee or apprentice is not considered payment in the breakdown of this variable

## WORKSTUD Col 212

### Work-based learning

#### Purpose

The variable uses as filter the group of persons who had work experience during HATLEVEL. WORKEXP=1-3 corresponds to work experience(s) during HATLEVEL which was/were either paid, or unpaid.

The variable further distinguishes the two kinds of work-based learning: apprenticeship (code 1) and mandatory traineeship (code 2). Apprenticeship is defined in this context as the mandatory work-based learning with a total duration of at least 6 months and paid. The distinction between apprenticeship and mandatory traineeship is based on duration and payment, and when is not possible to make it, then code 3 applies.

#### Notes

- in the AHM 2016 context, **persons having been apprentices during their HATLEVEL education** are those who (1) had working experience; where (2) training was a mandatory part of their curricula, (3) the period spent doing on-the-job training had a total duration of more than 6 months and (4) persons have received payment for that work
- starting from 2016, countries can collect information on ongoing apprenticeships by using code 5 of the LFS TEMPREAS variable: 'Person has temporary job/work contract of limited duration because it is a contract covering a period of apprenticeship'. Besides differences in the target group and the reference period, the TEMPREAS operational definition of apprenticeship differs<sup>2</sup> in several respects from the AHM 2016 one. Users should be made aware of these methodological differences
- the spontaneous answer 'some costs were reimbursed' (for example, travelling costs) in WORKSTUD\_Q4 is to be coded as WORKSTUD\_Q4=2 ('no payment')
- if practical aspects of the curricula are learned in the classroom, they are not taken into account by this variable (see question WORKSTUD\_Q3). As a result, HATVOC and WORKSTUD are not fully overlapping
- in case of alternating 'on-the-job training' and 'in-school learning' with various frequencies (for example, one day in a week at the work place, or one week in a month, etc), the on-the-job period is measured by adding up all periods of work experience outside classroom (even when interrupted by classroom sessions or school holidays)
- the AHM2016 definition of apprenticeships is not specifically linked to some HATLEVEL levels, like this is the case with the current LFS HATVOC variable: 'Orientation of the programme completed at the highest educational level'. Moreover, the formal education criterion is essential in the ISCED integrated mappings used by the LFS variables, while the AHM definition uses the young person's work experience as a starting point. Users should be made aware of these methodological differences

If there were several instances of work, and some were paid and some not, it is recommended that in WORKSTUD\_Q4, 'at least one' is coded as 'yes'.



## **ADDLEVEL Col 213/214**

Level of additional formal education

### **Purpose**

The variable ADDLEVEL complements the information in the core LFS on the highest level of educational attainment with the level of formal education that was started after reaching the highest level.

The target group consists of all persons who are not in education. For persons with HATLEVEL = 000 (no completed education), code 10 is the most likely answer in the ADDLEVEL variable. The combination HATLEVEL=000 and ADDLEVEL=00 is to be read as no participation in formal education.

The variable is important for vulnerable groups like early school leavers, and for checking the time-span between education (even if not successfully completed) and other events like starting work. It is also important for knowing both the levels and orientation of the studies not completed. All ISCED categories should be collected in the same way as for the LFS variables EDUCLEVEL and EDUCVOC.

### **Notes**

- EDUCSTAT wording is encouraged for making reference to the formal education. Adding national examples is a good practice
- the path Q1\_0 is optional for those countries where administrative data can be used to back the assumption that ADDLEVEL=10 for respondents with EDUCSTAT=2 and HATLEVEL=000

## **DROPREAS Col 215**

Reason for dropping out

### **Purpose**

The variable DROPREAS aims to capture the main reason why a person has abandoned the formal education started after HATLEVEL. This is particularly important for early school-leavers, namely for those who started a further study after their HATLEVEL. This information can be complemented by that from NCONREAS. For those who successfully completed the study, the question is not asked.

The target group of the variable consists of all persons who are not in education and started another study after reaching the highest level of education (HATLEVEL).

### **Notes**

- answering categories use the respondent's perspective, starting with the ones more linked to the educational outcome, and continuing with family or personal circumstances
- 'successful completion of the study' has the same meaning as for the HATLEVEL variable: study completed with a diploma or a qualification
- the spontaneous answer 'studies were too difficult' is included in code 1 as well

- costs of studying are seen in a broad sense, and they include fees, learning material and extra living costs. The spontaneous answers 'lack of financial means' is included here as well
- code 5 includes the lack of family support if seen as crucial by the respondent, as well as care responsibilities in the family (be them for own children, parents or other relatives) or other family reasons like for example the family changing home and disrupting the children's education
- code 6 refers to the own health, not to health problems in the family (this last case being covered by code 5)

The entry filter for the variable has been updated, so as to avoid asking respondents who did not know if they started a new study for the reason for leaving it and the date when they left it. The regulation text stays unchanged because it is not feasible to launch a procedure to change it, and because the updated model questionnaire filter is narrower than the original filter in the regulation. We recommend using the updated filter, but it is not officially required.

### **LEAVDATE Col 216/221**

Date of leaving formal education

#### **Purpose**

The variable LEAVDATE complements the HATYEAR information in the core LFS (date of acquiring with a diploma the highest level of educational attainment) with the date when finishing formal education with or without diploma in case someone started another study.

The target group of the variable consists of all persons who are not in education and started another study after reaching the highest level of education.

#### **Notes**

- the month of completion can be asked differently, by checking if it was a certain month, for example June in countries where the school year finishes in June

The entry filter for the variable has been updated, so as to avoid asking respondents who did not know if they started a new study for the reason for leaving it and the date when they left it. The regulation text stays unchanged because it is not feasible to launch a procedure to change it, and because the updated model questionnaire filter is narrower than the original filter in the regulation. We recommend using the updated filter, but it is not officially required.

### **NCONREAS Col 222**

Reason for not continuing education

#### **Purpose**

The variable NCONREAS aims to capture the main reason why a person did not continue education at a higher level than their HATLEVEL if HATLEVEL corresponds to ISCED 5 or lower. This is particularly important for early school-leavers. This information can be complemented by that from

DROPREAS. For persons with HATLEVEL corresponding to university studies it was considered that the variable is likely to result in NCONREAS=0, and this is the reason why this data is not collected.

The target group of the variable consists of all persons who are not in education and did not start another study after reaching the highest level of education, while their HATLEVEL is not higher than secondary education.

### Notes

- answering categories use the respondent's perspective, starting with the ones more linked to the educational outcome, and continuing with family or personal circumstances
- categories 1 and 3 include hypothetical components: the person did not start a new formal education anticipating either high fees (or high living costs during education) or difficulty of the next level of studies
- examples of situations grouped under 'other': wanting to become a conscript, lack of knowledge on the education system and the existing possibilities to continue studying, etc

Filter update for NCONREAS\_Q1 to avoid asking persons who cannot say if they participated in formal education why they were not continuing their education.

## SUPPORT Col 223

Support received for finding work

### Purpose

The variable SUPPORT aims to capture if persons received free of charge support for finding a job from the local public employment office or central government or other bodies. If that was the case, the most helpful type of support is collected from the subjective perspective of the respondent.

The variable includes the reference period of the twelve months preceding the reference week.

The target group of this variable consists of all young persons, excepting those who have worked for the same employer during the full year preceding the interview.

### Notes

- STARTIME is the derived core LFS variable measuring in months the time elapsed since the person has started to work for the current employer or as a self-employed
- 'a job' in SUPPORT\_Q1 has the meaning of paid work
- the information 'free of charge' in SUPPORT\_Q1 is needed only in countries where beneficiaries can have access to paying support
- 'the Public Employment Office or other institution' are adapted at national level. National examples are encouraged. The Public Employment Office is the same as in the REGISTER variable. 'Other institutions' are the other offices in charge with implementing the EU Youth Guarantee, as well as educational institutions like universities
- access to job vacancies is included in code 1
- answering category 'placement in a work programme' is to be replaced and/or completed with

national examples of schemes where the states subsidy the ‘first jobs’ of young people – if applicable

- the spontaneous answer 'I have never looked for a job' is included in SUPPORT\_Q1=2.

## **FINDMETH Col 224**

Method of finding current job

### **Purpose**

The variable checks which was the method used by young people to find their current, main job. The question is asked to all employees.

### **Notes**

- if several methods were applied at the same time, the most important method will be selected from the point of view of the job finder
- in the case of a trainee who gets a job after a period of traineeship/internship for the same employer, answers 6 or 7 may apply, depending on the particular situation. The same applies to persons getting a different job while working for the same employer

## **OKLEVEL Col 225**

Appropriateness of job given the respondent’s level of education

### **Purpose**

The variable OKLEVEL collects young people's perceptions as to whether their level of education matches the demands of their current job. It gives a measure of mismatches between, on one hand, the existing level of education and, on the other hand, that necessary in the current, main job. It is a subjective assessment, as perceived by respondents.

The target group consists of all young people in employment.

### **Notes**

- the young person's formal education includes all diploma/qualifications acquired before and including HATLEVEL, as well as formal studies following HATLEVEL (including ongoing, not completed studies)

## MOVE4JOB Col 226

### Willingness to move for job

#### Purpose

The variable MOVE4JOB aims to capture the effort that young people made or are willing to make for being in employment. It collects information about moving home (with information on national, intra-EU or outside-EU mobility). For persons in employment, it is checked if young people moved home for their current main job. For young people who are not in employment, it is checked whether they would be willing to move home.

The target group consists of all young persons. The question has different formulations for those in employment (WSTATOR=1,2) on one hand and for those not in employment (WSTATOR=3 to 5) on the other hand. Different formulations for those being employees (STAPRO=3) or not (STAPRO=1,2,4) are available, their usage being optional.

#### Notes

- the variable refers to the main job only
- 'place of residence / home' is to be translated as usual place of residence and not the legal one. The EU Labour Force Survey Explanatory Notes<sup>3</sup> provides the users, on page 4, with the general definition of the resident population in the LFS and its application to special cases (for example, students)
- the EU of 28 member states is composed of: <list of countries: [http://europa.eu/about-eu/countries/index\\_en.htm](http://europa.eu/about-eu/countries/index_en.htm)>. Countries where 'Europe' is a good proxy for 'the European Union' can use 'Europe' instead
- countries may offer more detailed answering categories for the mobility within the country, for example by NUTS2 or NUTS 3 levels
- the information collected by MOVE4JOB\_Q2A can be collected in two questions, the second one collecting the precise country and coding it according to the variable's specifications
- the spontaneous answer 'I would be prepared to move anywhere' is included in MOVE4JOB\_Q2B=3
- the spontaneous answer 'I do not want to have work' in MOVE4JOB\_Q1B, corresponding to WANTWORK=2, is to be coded as MOVE4JOB\_Q1B=2

## CMT4JOB Col 227

### Willingness to commute for job

#### Purpose

The variable CMT4JOB aims to capture the effort that young people made or are willing to make for being in employment. It collects information about accepting a long commute. For persons in employment, it is checked if young people accepted a long commute for their current main job. For young people who are not in employment, it is checked whether they would be willing to accept long travelling times.

The target group consists of all young persons. The question has different formulations for those in employment (WSTATOR=1,2) on one hand and for those not in employment (WSTATOR=3 to 5) on the other hand.

### Notes

- the variable refers to the main job only
- 'journey from home to work' is the equivalent of 'commuting' – the best one can be chosen, to mean: one way travelling time from home to work, expressed as average time. This is particularly relevant for countries where the national translation of 'commuting' means only travelling to a different town
- spontaneous answers 'my place of work is residence/home' in CMT4JOB\_Q1A, roughly corresponding to HOMEWK=1, is to be coded as CMT4JOB\_Q1A=2
- spontaneous answers 'I do not want to have work' in CMT4JOB\_Q1B, corresponding to WANTWORK=2, is to be coded as CMT4JOB\_Q1B=2

Code 2 of the variable should have had an 'or' between the two elements, not an 'and', following the structure of code 1.

### Specifications of the 2014 ad hoc module on the labour market situation of migrants and their immediate descendants

Column	Code	Description	Filters/remarks
<b>BACKGROUND OF TARGET POPULATION</b>			
211/212	COBFATH	<b>Country of birth of father</b> 2-digit ISO country classification	Everybody aged 15 to 64
	98	Country unknown but father born abroad	
	99	Not applicable (not included in filter)	
	Blank	Unknown	
213/214	COBMOTH	<b>Country of birth of mother</b> 2-digit ISO country classification	Everybody aged 15 to 64
	98	Country unknown but mother born abroad	
	99	Not applicable (not included in filter)	
	Blank	Unknown	
215	PARHAT	<b>Level of educational attainment of parents</b> <i>Highest level of education successfully completed by father or mother</i>	Everybody aged 15 to 64
	1	Low (ISCED 2011 0-2)	
	2	Medium (ISCED 2011 3-4)	
	3	High (ISCED 2011 5-8)	
	9	Not applicable	
	Blank	Unknown	
216/217	WORKOTHC	<b>Last country of work abroad</b> <i>Country code of country other than current country of residence where person worked and lived for a period of 6 months or longer in the last 10 years</i> 2-digit ISO country classification	Everybody aged 15 to 64
	00	Has not worked abroad in last 10 ten years	
	98	Country unknown but has worked abroad	
	99	Not applicable	
	Blank	Unknown	
218	MIGREAS	<b>Reason for migrating</b> <i>Main reason for last migration into the host country</i>	YEARSID ≠ 00
	1	Employment, job found before migrating	
	2	Employment, no job found before migrating	
	3	Family reasons	
	4	Study	
	5	International protection or asylum	
	6	Other	
	9	Not applicable (not included in filter)	
	Blank	Unknown	

**Specifications of the 2014 ad hoc module on the labour market situation of migrants and their immediate descendants, cont'd**

Column	Code	Description	Filters/remarks
		<b>OBSTACLES TO LABOUR MARKET PARTICIPATION</b>	
219	OVERQUAL	<b>Over-qualified for job</b> <i>Qualifications and skills of the person would allow more demanding tasks than current job</i>	WSTATOR = 1, 2
	1	Yes	
	2	No	
	9	Not applicable (not included in filter)	
	Blank	Unknown	
220	JOBOST1	<b>Main obstacle to getting suitable job</b> <i>Main obstacle to getting a job corresponding to the person's qualifications or to getting a job at all</i>	(YEARSID ≠ 00 or father or mother is foreign-born) and (OVERQUAL = 1 or WSTATOR = 3 – 5)
	1	Lack of language skills in host country	
	2	Lack of recognition of qualifications obtained abroad	
	3	Restricted right to work because of citizenship or residence permission	
	4	Origin, religion or social background	
	5	Other obstacle	
	6	No particular obstacle	
	9	Not applicable (not included in filter)	
	Blank	Unknown	
221	JOBOST2	<b>Second obstacle to getting suitable job</b> <i>Second main obstacle to getting a job corresponding to the person's qualifications or to getting a job at all</i>	JOBOST1 = 1 – 5
	1	Lack of language skills in host country	
	2	Lack of recognition of qualifications obtained abroad	
	3	Restricted right to work because of citizenship or residence permission	
	4	Origin, religion or social background	
	5	Other obstacle	
	6	No second obstacle	
	9	Not applicable (not included in filter)	
	Blank	Unknown	
222	LANGHOST	<b>Skills in host country language</b> <i>Degree of command of speaking the main host country language</i>	YEARSID ≠ 00
	1	Language is mother tongue	
	2	Advanced	
	3	Intermediate	
	4	Beginner or less skills	
	9	Not applicable (not included in the filter)	
	Blank	Unknown	



**Specifications of the 2014 ad hoc module on the labour market situation of migrants and their immediate descendants, cont'd**

Column	Code	Description	Filters/remarks
223	LANGCOUR	<b>Participation in language course</b> <i>Attendance at a host country language course since arrival in host country</i>	YEARSID ≠ 00
	1	Yes	
	2	No, was not necessary	
	3	No, for other reasons	
	9	Not applicable (not included in filter)	
	Blank	Unknown	
224	FINDMETH	<b>Method finding current job</b> <i>Method used to find current job in case of a job found in the last 5 years</i>	STATPRO = 3 and (REFYEAR – YSTARTWK ≤ 5)
	1	Advertisements, via any channel	
	2	Relatives, friends or acquaintances	
	3	Public employment office	
	4	Private employment agency	
	5	Education or training institution	
	6	Contacted employer directly	
	7	Employer contacted person directly	
	8	Other method	
	9	Not applicable (not included in filter)	
	Blank	Unknown	
<b>TECHNICAL VARIABLES</b>			
225/230	COEFF_14	<b>AHM weighting factor</b> <i>Weighting factor for the ad hoc module in case of sub-sampling or Unit non-response.</i>	
	0000-9999	Columns 225 – 228 contain whole numbers	
	00-99	Columns 229 – 230 contains decimal places	

COBFATH Country of birth of father (Eurostat AHM 2014 Columns 211-212)

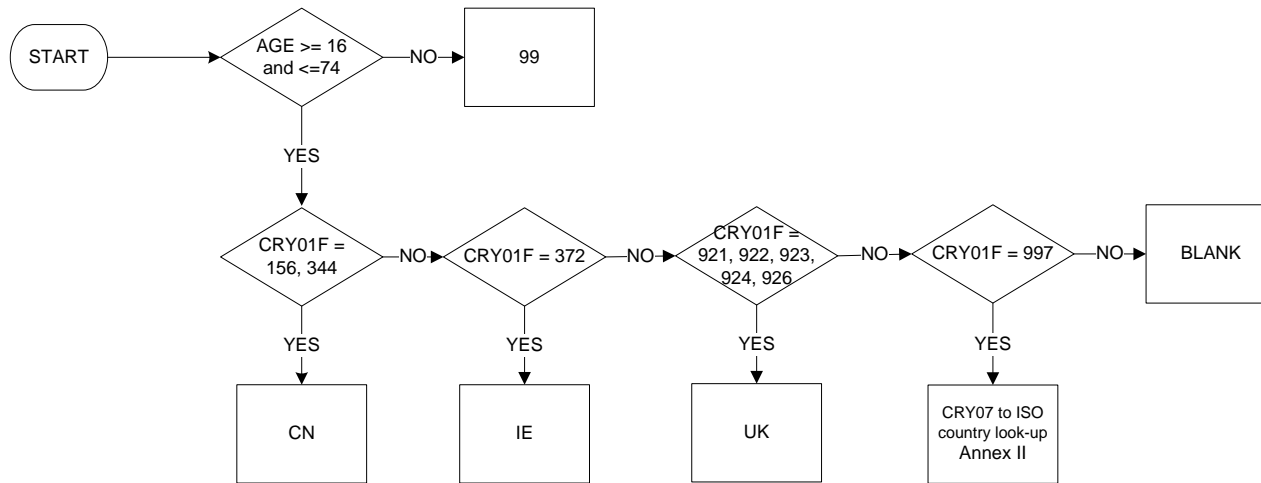

<b>CRY01F</b>	
156	China
344	Hong Kong
372	Republic of Ireland
921	England
922	Northern Ireland
923	Scotland
924	Wales
926	UK, Britain NOS
997	Other

COBMOTH Country of birth of mother (Eurostat AHM 2014 Columns 213-214)

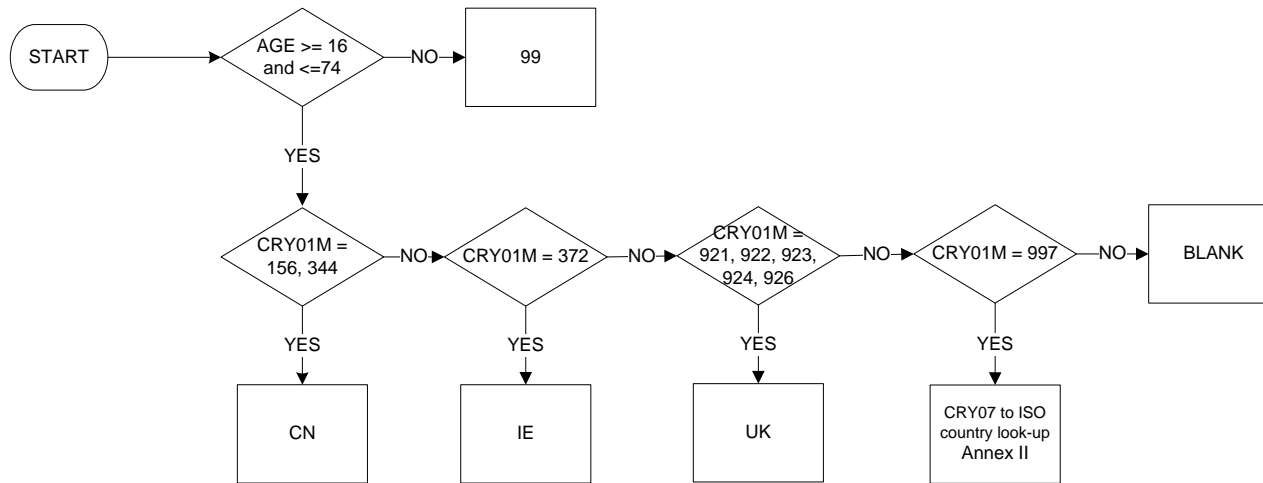

<b>CRY01M</b>	
156	China
344	Hong Kong
372	Republic of Ireland
921	England
922	Northern Ireland
923	Scotland
924	Wales
926	UK, Britain NOS
997	Other

PARHAT Level of educational attainment of father or mother (Eurostat AHM 2014 Col 215)

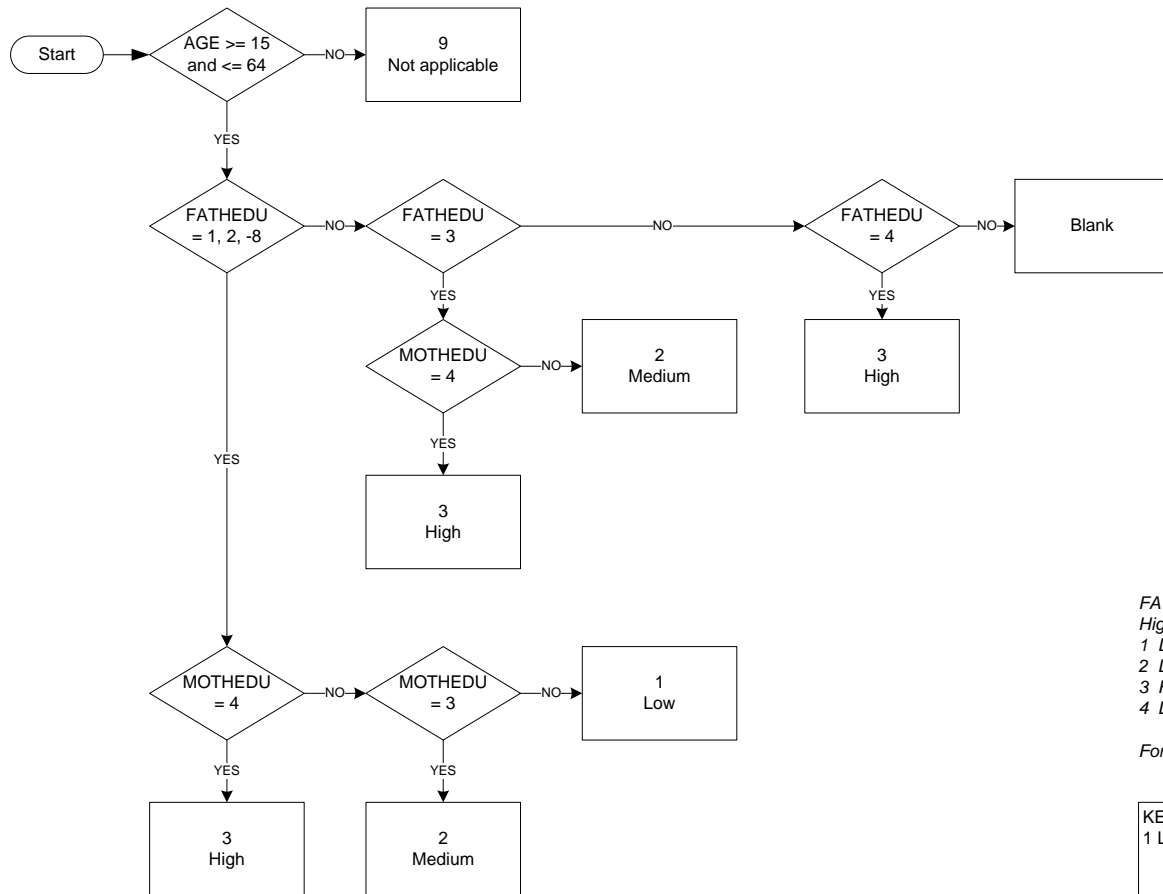

*FATH/MOTHEDU*  
Highest qualification of father/mother  
1 Did not attend school  
2 Less than five GCSEs  
3 Five or more GCSEs or any A-levels  
4 Degree level or higher (including Foundation Degree)

For further details see LFS User Guide vol. 2 (2014)

KEY	
1 Low :	No formal education or below ISCED 1 ISCED 1 ISCED 2 (inc ISCED 3 programmes of duration less than 2 years)
2 Medium :	ISCED 3 programme duration >= 2 years, sequential ISCED 3 programme duration >= 2 years (N/A in UK) ISCED 3 with access to ISCED 5, 6 or 7
3 High :	ISCED 4 (N/A in UK) ISCED 5 ISCED 6 ISCED 7 ISCED 8
9 Not applicable :	(age < 15 or age > 64)

MIGREAS Main reason for migrating (Eurostat AHM 2014 Col 218)

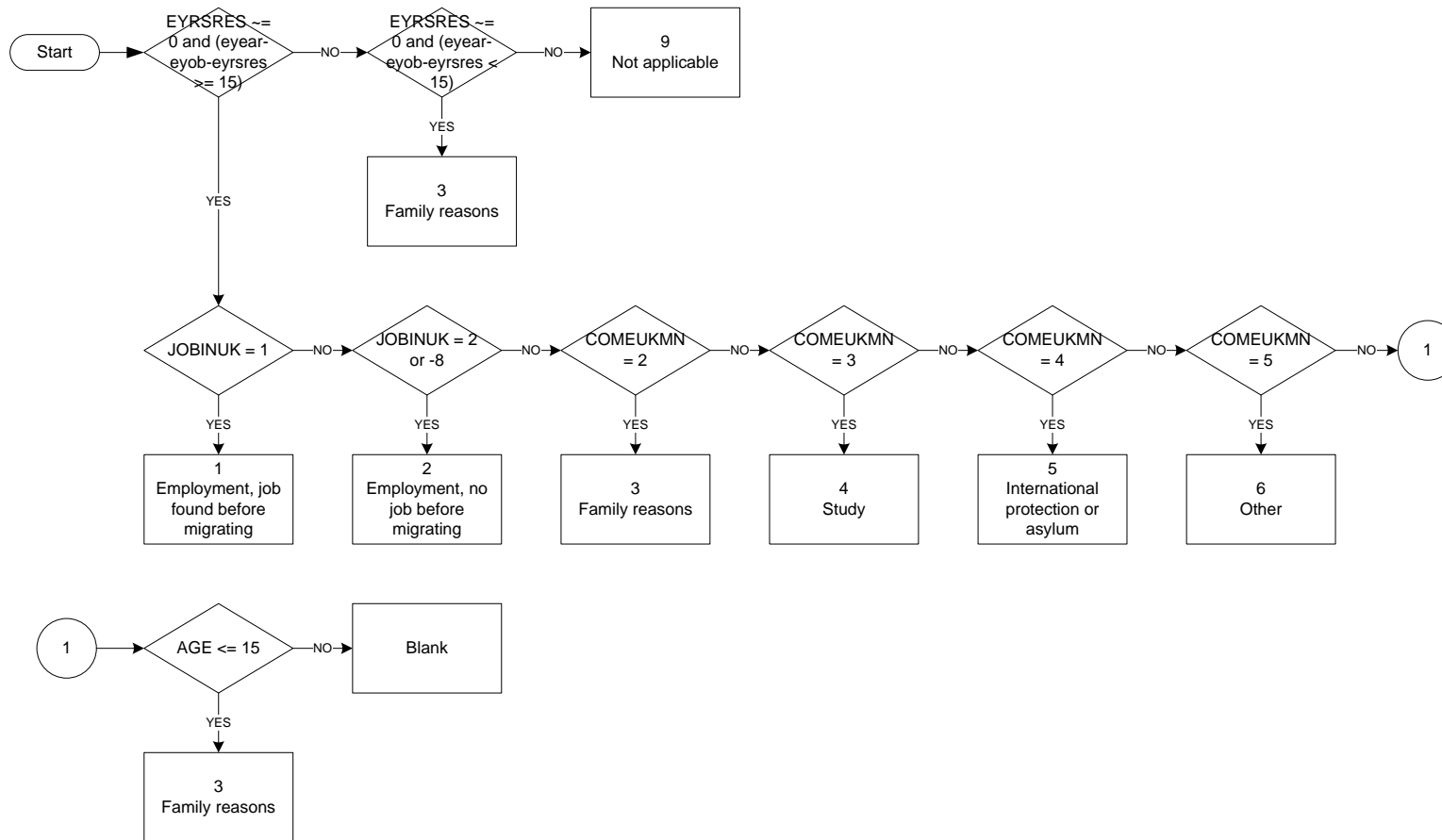

Explanation of filter condition.  
If the respondent entered the country at less than age 15 then the reason for migrating is assumed to be 'family reasons'.

OVERQUAL Whether overqualified for job (Eurostat AHM 2014 Col 219)

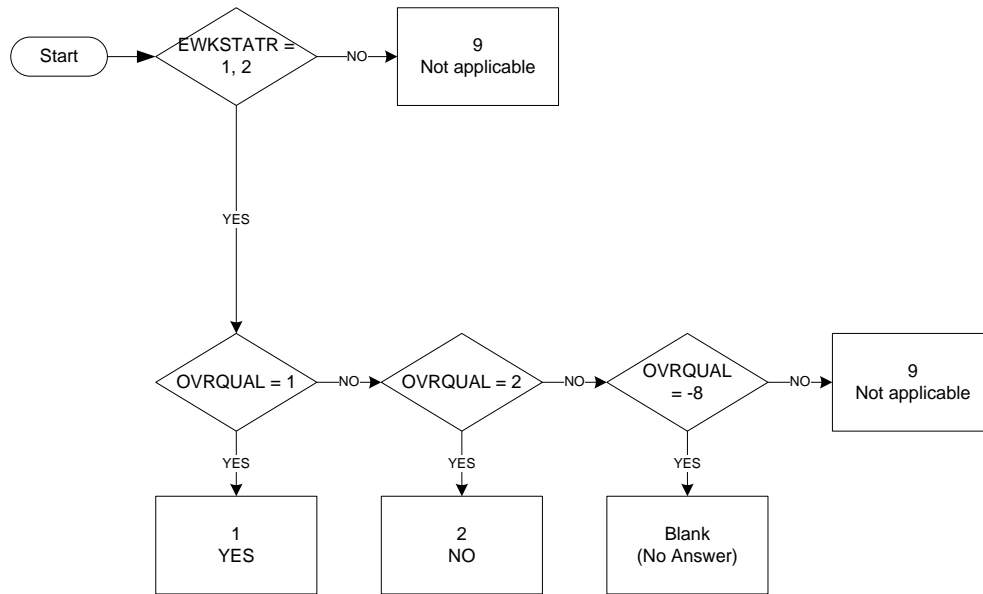

OVRQUAL  
Do you feel overqualified for your current main job?  
1 Yes  
2 No

For further details see LFS User Guide vol. 2 (2014)

JOBOST1 Main obstacle to getting suitable job (Eurostat AHM 2014 Col 220)

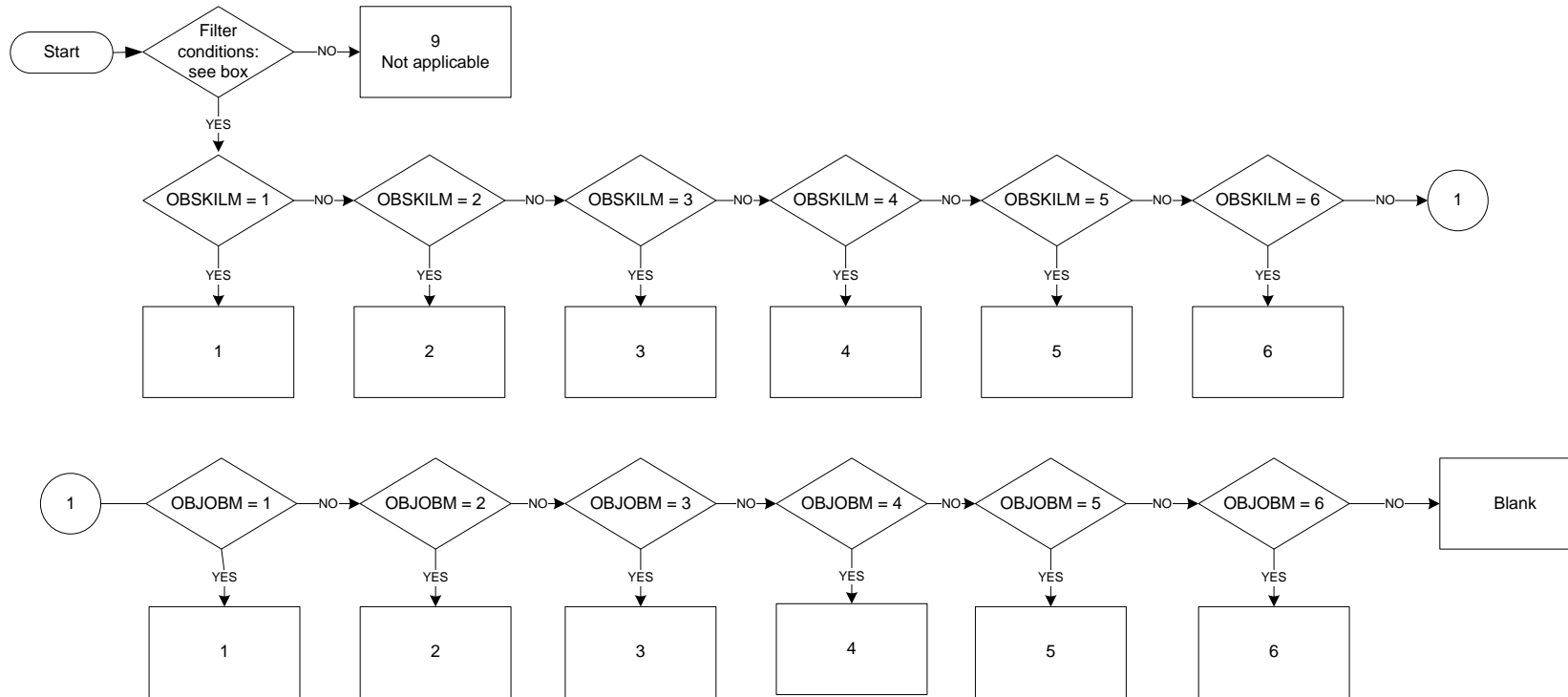

KEY (JOBOST1) and  
OBSKILM main reason for respondent feeling overqualified for current main job,  
OBJOBM main reason that prevent respondent from having a job.  
1 Lack of English language skills  
2 Non-UK qualifications not recognised  
3 Restricted rights to work because of citizenship or residence permissions  
4 Origin, religion or social background  
5 Something else  
6 No particular reason

For further details of both variables see LFS User Guide vol. 2 (2014)

Filter condition.  
(eyrsres == "00" OR cobfath == "UK" OR cobmoth == "UK") AND (ovrqual = 1 OR ewkstatr = 5)  
i.e.  
Condition 1: Years of residence (in UK) greater than zero OR Country of birth of father is not UK OR country of birth of mother is not UK.  
AND  
Condition 2: Respondent is overqualified for current main job OR respondent is not working and does not have a job.

JOBOST2 Second obstacle to getting suitable job (Eurostat AHM 2014 Col 221)

Start date: Jan 2014  
End date: Dec 2014

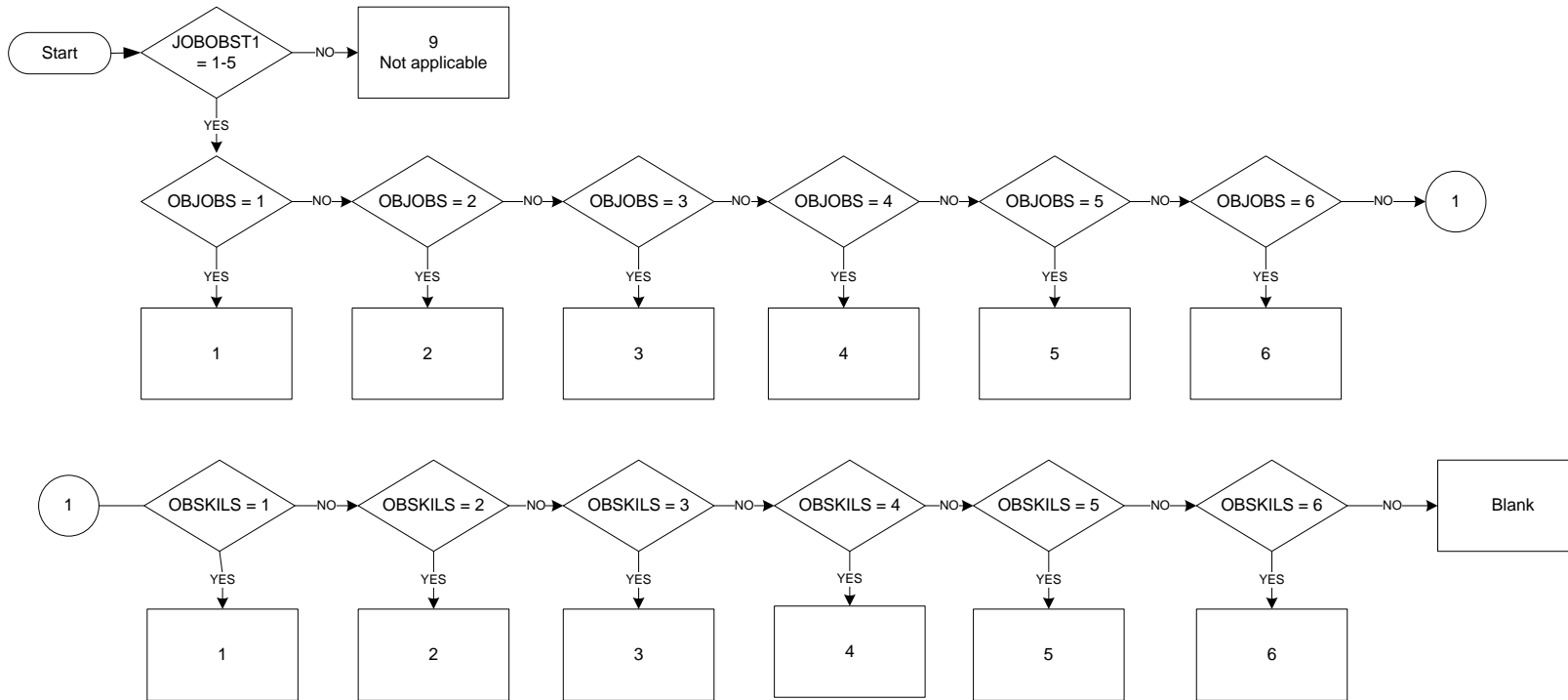

KEY (JOBOST2) and  
*OBSKILS* second reason for respondent feeling overqualified for current main job,  
*OBJOBS* second reason that prevents respondent from having job  
 1 Lack of English language skills  
 2 Non-UK qualifications not recognised  
 3 Restricted rights to work because of citizenship or residence permissions  
 4 Origin, religion or social background  
 5 Something else  
 6 No particular reason

For further details of both variables see LFS User Guide vol. 2 (2014)



LANGHOST Skills in host country's language (Eurostat AHM 2014 Col 222)

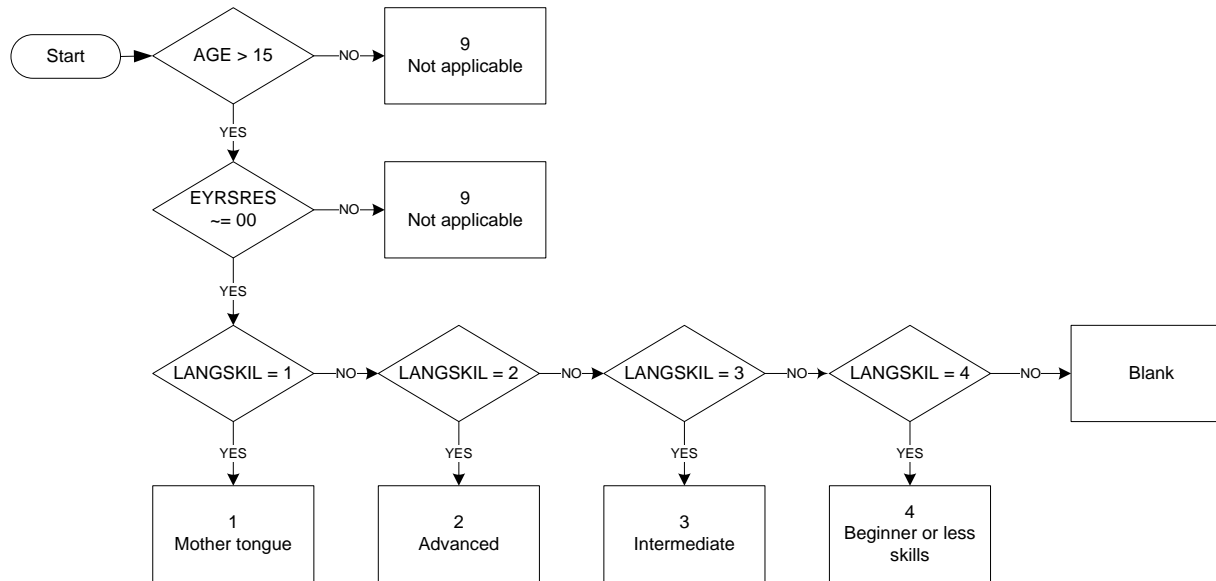

LANGSKIL would you describe your English spoken language as...

- 1 Mother tongue
- 2 Advanced
- 3 Intermediate
- 4 Beginner or less

For further details see LFS User Guide vol. 2 (2014)

LANGCOUR Participation in language courses (Eurostat AHM 2014 Col 223)

Start date: Jan 2014  
End date: Dec 2014

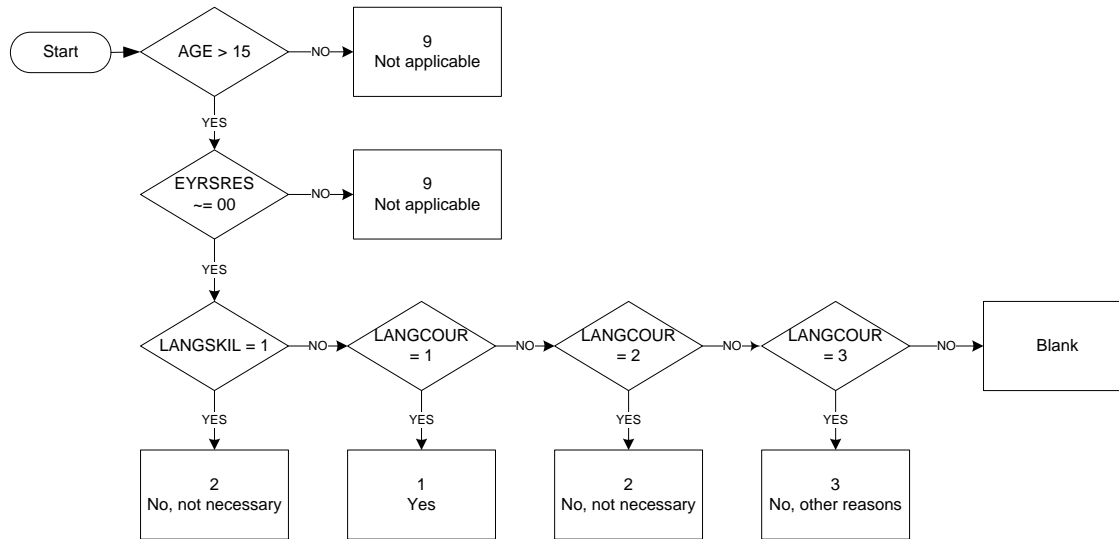

LANGSKIL would you describe your English spoken language as...  
1 Mother tongue

LANGCOUR whether taken part in English language course since arrival in UK  
1 Yes  
2 No, not necessary  
3 No, for other reasons

For further details see LFS User Guide vol. 2 (2014)

Version 2 04/06/2014

FINDMETH Method of finding current job (Eurostat AHM 2014 Col 224)

Start date: Jan 2014  
End date: Dec 2014

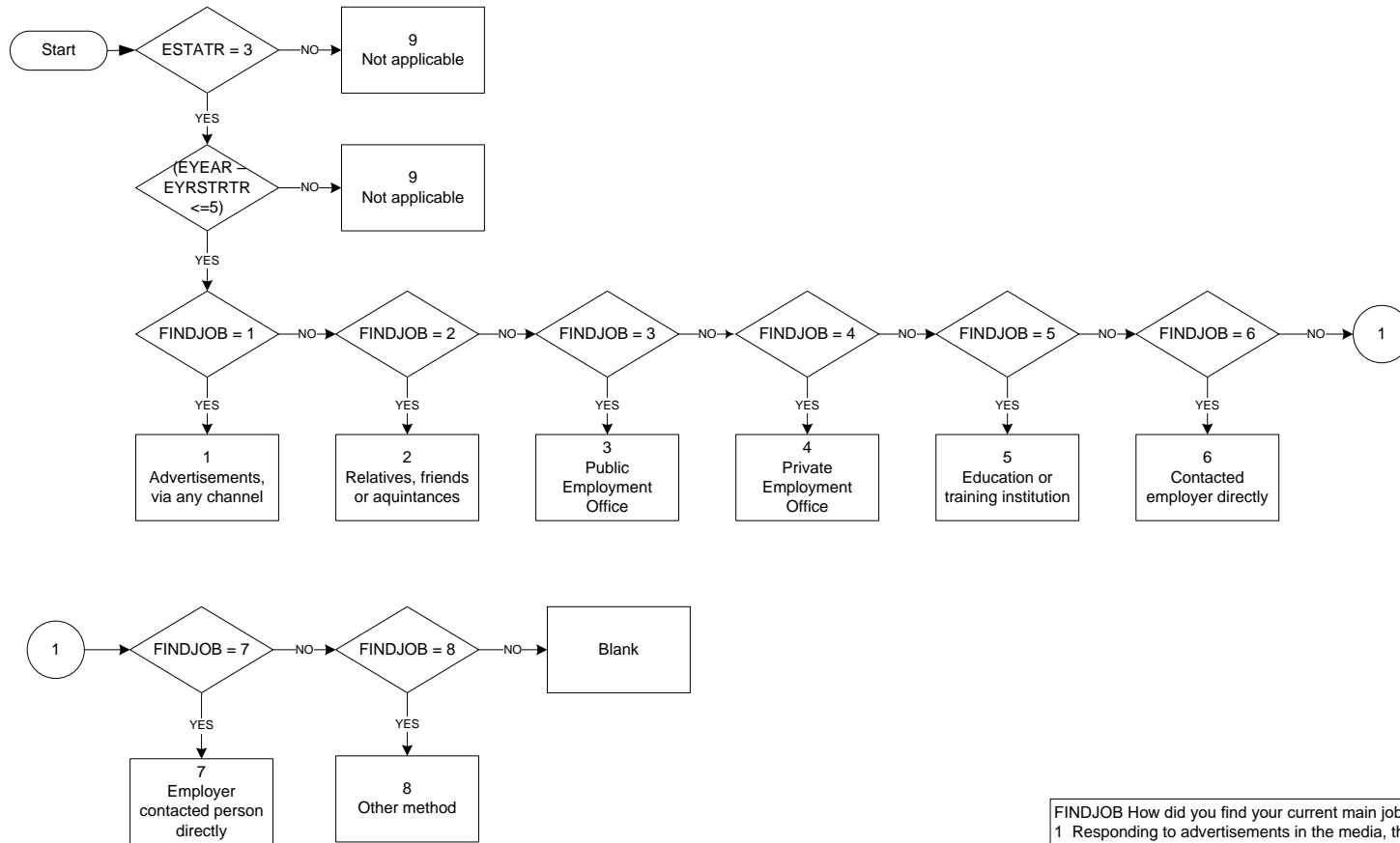

FINDJOB How did you find your current main job...

- 1 Responding to advertisements in the media, the internet or another channel
- 2 Through relatives, friends or acquaintances
- 3 Via a Jobcentre/Job-market or Jobs and Benefits Centre
- 4 Via a private employment agency
- 5 Through an education or training institution
- 6 By direct application to the employer
- 7 Employer contacted you directly
- 8 Some other method

For further details see LFS User Guide vol. 2 (2014)

Version 2 04/06/2014

## **LFS ad hoc module 2014 on the labour market situation of migrants and their immediate descendants**

### **Annex to the model questionnaire**

*This document provides additional clarification for the variables of the module. The variables are primarily specified by the model questionnaire. However, there will always remain some room for interpretation, elements that are not fully clear, grey areas or special cases for which more guidance is needed. This document attempts to give this guidance.*

*The content is to a large degree determined by the feedback that is received from NSI's when implementing the module. As a result, the document is a live document in need for updating in the period that the module is implemented. New versions are disseminated at regular time intervals.<sup>1</sup>*

## **COBFATH Col 211/212 and COBMOTH Col 213/214**

### *Social vs. biological parent*

For consistency with the core, the social parent will be considered rather than the biological one. In the core LFS, there is no distinction made between biological and non-biological children when the biological parent is different from the social parent - in the case of adopted children or step children. Moreover, the non-biological (social) aspect is perhaps more important from an educational perspective (see PARHAT variable) than the biological one. Not least, biological parents are sometimes not known, while social parents could be in the household (then, PARHAT derived from HATLEVEL).

Parent born in a country that no longer exists

In the case of countries whose borders changed since the birth of the parent (e.g. Yugoslavia), the current equivalent is needed. Consequence: limited usage of some register-based information.

## **PARHAT Col 215**

Successfully completed level of education

The level completed with diploma is understood as a successfully completed level.

Reference for the level of educational attainment

The host country is the reference for educational attainment, and ISCED 2011 equivalents in host country are encouraged to be made available as examples.

## **WORKOTHC Col 216/217**

Link between working (and living); commuting workers; different periods of working and living

---

<sup>1</sup> *The most recent version is available under the CIRCABC link :*

[https://circabc.europa.eu/faces/jsp/extension/wai/navigation/container.jsp?FormPrincipal:\\_idcl=FormPrincipal:\\_id3&FormPrincipal\\_SUBMIT=1&id=a0b9e306-47bc-45f9-972f-a82487ffbe3d&javax.faces.ViewState=r00ABXVyABNbTGphdmEubGFuZy5PYmplY3Q7kM5YnxBzKWwCAAB4cAAAAAN0AAIxMHB0ACsvanNwL2V4dGVuc2lvbi93YWkvbmF2aWdhdGlubi9jb250YWluZXIuanNw](https://circabc.europa.eu/faces/jsp/extension/wai/navigation/container.jsp?FormPrincipal:_idcl=FormPrincipal:_id3&FormPrincipal_SUBMIT=1&id=a0b9e306-47bc-45f9-972f-a82487ffbe3d&javax.faces.ViewState=r00ABXVyABNbTGphdmEubGFuZy5PYmplY3Q7kM5YnxBzKWwCAAB4cAAAAAN0AAIxMHB0ACsvanNwL2V4dGVuc2lvbi93YWkvbmF2aWdhdGlubi9jb250YWluZXIuanNw)

The focus of the variable is on the work aspect. This is visible also in the formulation of the second question. The residence element ('and lived') is added to clarify that commuting workers are not the target group of this variable. However, preliminary tests have shown that for non-commuting persons it is confusing to reply to a question where both 'work and lived' are present.

Also if different periods of working and living are concerned (one under and other above six months), the work element remains prevailing.

For persons residing in the country for less than 10 years it is more likely to have WORKOTHC <>00.

Case of more sequences of work in the same country; several countries of work

In order not to burden respondents with adding up several time periods, one of these periods should be of at least six months to be considered as valid answer. If more (long) periods were spent in different countries, then the last one is recorded.

## **MIGREAS Col 218**

Main reason obtained from two questions

Practice showed that there is often a combination of reasons playing a role in migration. Isolating one single reason might require time for a respondent, but this is a cognitive process that respondents considered relevant, even crucial for this survey. These are the reasons why a more iterative process is designed, with more reasons accepted first as answers and only afterwards identifying the main reason.

Person was younger than 15 when he came

If person was younger than 15 when (s)he came in the country [namely, REFYEAR-YEARBIR<YEARESID+15], code 3 is automatic: Family reasons .

Categories differ in the variable and questionnaire

Categories are intentionally different, because in this particular case dealing with international protection, official terms are less understood by the respondent.

Informal employment

Every kind of job that was offered (both formal and informal) should be included here. Informal work, seasonal work or other temporary work are all included.

## **JOBOST1 Col 220 and JOBOST2 Col 221**

Filter JOBOST1

The question is addressed to all persons who considered themselves overqualified while at work (irrespective of migration background), as well as to the migrants and their immediate descendants who are not in employment.

'Suitable job' not needed

This situation is included under code 6: no particular obstacle.

Spontaneous answer: discrimination

If 'discrimination' is the spontaneous answer, then code 4 (origin, religion and social background) is applicable.

Spontaneous answer: neighbourhood with bad reputation

It could be that persons say that the place where they live being a neighbourhood with a bad reputation is an obstacle preventing them to have a job. It is preferable to use the category 'origin, religion or social background' in this case. This category, and mainly the 'social background' aspect is the closest to the concept of neighbourhood.

The person already does not work /work PT because of family responsibilities

Even if family responsibilities were the cause for the reduced presence in work, several other codes could be eligible for the answer at this question on obstacles. Interesting results could result from the combined information from FTPREAS/SEEKREAS and this variable.

## LANGHOST Col 222

Reference for establishing the degree of command of a language

The reference is the European Framework of Reference for Languages. The self-assessment grid is available for all languages, at link:

<http://europass.cedefop.europa.eu/en/documents/language-passport/examples>.

For the purpose of this variable, spoken interaction and level 1 (A1 for beginner, B1 for intermediate and C1 for advanced) are considered. The full text from the self-assessment grid for each level is available below. The questionnaire could use the bold part as support for respondents, to read:

How do you consider your language skills in speaking [language]?

1. Mother tongue: *I speak the language as a native speaker or language is my mother tongue*
2. Advanced: *I can use language flexibly and effectively for social and professional purposes*
3. Intermediate: *I can enter unprepared into conversation on topics that are familiar*
4. Beginner or less skills: *I can ask and answer simple questions on very familiar topics or I do not speak the language at all*

Advanced

'I can express myself fluently and spontaneously without much obvious searching for expressions. **I can use language flexibly and effectively for social and professional purposes.** I can formulate ideas and opinions with precision and relate my contribution skilfully to those of other speakers.' (C1 level in the self-assessment grid)

Intermediate

'I can deal with most situations likely to arise whilst travelling in an area where the language is spoken. **I can enter unprepared into conversation on topics that are familiar**, of personal interest or pertinent to everyday life (e.g. family, hobbies, work, travel and current events).' (B1 level in the self-assessment grid)

Beginner

'I can interact in a simple way provided the other person is prepared to repeat or rephrase things at a slower rate of speech and help me formulate what I'm trying to say. **I can ask and answer simple questions** in areas of immediate need or **on very familiar topics**.' (A1 level in the self-assessment grid)

No knowledge of a language

The case of a language which is not known at all is included in code 4.

Main language of the host country

For countries with more official languages, or where more languages are relevant at regional level for labour market purposes, countries could consider adapting the national questionnaire and repeating the question for the languages of relevance.

When information is collected for more official languages, LANGHOST is filled in for the language where the respondent performed best. Eurostat is informed about the coverage of languages, in order to allow users to correctly interpret EU data.

### LANGCOUR Col 223

Regular school education providing language classes

Language lessons in normal/regular school education are not understood as 'language courses' in the context of this variable. Participants in the regular school education are usually the young people under 20, or language students at universities – but in those cases the motivation is educational and less linked to a successful integration. In these cases, code 2 is recommended.

Public vs. private course provider

For the purpose of this variable, both public and private courses are considered. During the preparation of the module, the public provider was considered as more relevant for the public spending on labour market measures, while private providers gave more a measure of the personal motivation. However, selecting only public providers might be difficult to implement in practice. If countries consider the distinction relevant, they can make it at national level and aggregate the information for the EU level.

### FINDMETH Col 224

Several methods could be applicable

In case that several methods were applied at the same time, the most important method should be selected from the point of view of the job finder.

Training provided by the Public Employment office

If the job was found after having a training initiated by the PEO code 3 should be used. Code 5 should be applied for cases where the job was found through the network of the formal education and training institution or as a result of an internship in the context of this education programme.

**Specifications of the 2013 ad hoc module accidents at work and other health related problems**

Column	Code	Description	Filters/remarks
197	AWNUMBR	<b>Accidents at work in the last 12 months</b> <i>Accidents at work resulting in injuries occurred in the 12 months before the reference week.</i>	(WSTATOR=1,2) or (WSTATOR=3-5 and EXISTPR=1 and YEARPR and MONTHPR is not prior to 1 year before the reference week)
	0	None	
	1	One	
	2	Two or more	
	9	Not applicable (not included in filter)	
	Blank	Unknown	
198	AWROAD	<b>Type of accident at work</b> <i>Whether the most recent accident at work was a road traffic accident</i>	AWNUMBR = 1, 2
	1	A road traffic accident	
	2	Accident other than road traffic accident	
	9	Not applicable (not included in filter)	
	Blank	Unknown	
199	AWJOB	<b>Job of accident</b> <i>Job done when most recent accident at work resulting in injury occurred. Use the first code that applies</i>	AWNUMBR = 1, 2
	1	Main current job	
	2	Second current job	
	3	Last job (for persons not in employment only)	
	4	Job one year ago	
	5	Some other job	
	9	Not applicable (not included in filter)	
	Blank	Unknown	
200/201	AWDOFF	<b>Period off work because of the accident</b> <i>Number of calendar days – excluding the day of the accident – in the 12 months before the reference week the person was unfit to work because of the most recent accident resulting in injury.</i>	AWNUMBR = 1, 2
	00	Still off work because has not yet recovered from the accident but, expects to resume work later	
	01	Expects never to work again because of this accident	
	02	Less than one day or no time off	
	03	At least one day but less than four days	
	04	At least four days but less than two weeks	
	05	At least two weeks but less than one month	
	06	At least one month but less than three months	
	07	At least three months but less than six months	
	08	At least six months but less than nine months	
	09	Between nine and twelve months	
	99	Not applicable (not included in filter)	
	Blank	Unknown	



**Specifications of the 2013 ad hoc module accidents at work and other health related problems, cont'd.**

Column	Code	Description	Filters/remarks
202	AWDOFF	<b>Work related health problems</b> <i>Physical or mental health problem(s) suffered by the person in the 12 months before the reference week that was (were) caused or made worse by work apart from the previously recorded accidents(s) at work.</i>	(WSTATOR=1,2) or (WSTATOR=3-5 and EXISTPR=1)
	0	None	
	1	One	
	2	Two or more	
	9	Not applicable (not included in filter)	
	Blank	Unknown	
203/204	WHPTYPEP	<b>Type of work related health problem</b> <i>Type of the most serious health problem caused or made worse by work</i>	WHPNUMBR = 1, 2
	00	Bone, joint or muscle problem which mainly affects neck, shoulders, arms or hands	
	01	Bone, joint or muscle problem which mainly affects hips, knees,	
	02	legs or feet	
		Bone, joint or muscle problem which mainly affects back	
	03	Breathing or lung problem	
	04	Skin problem	
	05	Hearing problem	
	06	Stress, depression or anxiety	
	07	Headache and/or eyestrain	
	08	Heart disease or attack, or other problems in the circulatory system	
	09	Infectious disease (virus, bacteria or other type of infection)	
	10	Stomach, liver, kidney or digestive problem	
	11	Stomach, liver, kidney or digestive problem	
	99	Other types of health problem	
	Blank	Not applicable (not included in filter)	
		Unknown	
205	WHPLIMAB	<b>Health problem limiting daily activities</b> <i>Whether the most serious health problem caused or made worse by work limits the ability to carry out day to day activities either at work or outside work</i>	WHPNUMBR = 1, 2
	0	No	
	1	Yes, to some extent	
	2	Yes, considerably	
	9	Not applicable (not included in filter)	
	Blank	Unknown	

**Specifications of the 2013 ad hoc module accidents at work and other health related problems, cont'd.**

206	WHPJOB	<b>Job of health problem</b> <i>Job that caused or made worse the most serious health problem</i> <i>(Use the first code of the list that applies).</i>	WHPNUMBR = 1, 2
	1	Main current job	
	2	Second current job	
	3	Last job (for persons not in employment)	
	4	Job one year ago	
	5	Some other job	
	9	Not applicable (not included in filter)	
	Blank	Unknown	
207/208	WHPDOFF	<b>Period off work because of health problem</b> <i>Number of calendar days in the 12 months before the reference week the person was unfit to work because of the most serious health problem caused or made worse by work.</i>	WHPNUMBR = 1, 2
	00	Still off work because has not yet recovered from the accident but, expects to resume work later	
	01	Expects never to work again because of this accident	
	02	Less than one day or no time off	
	03	At least one day but less than four days	
	04	At least four days but less than two weeks	
	05	At least two weeks but less than one month	
	06	At least one month but less than three months	
	07	At least three months but less than six months	
	08	At least six months but less than nine months	
	09	Between nine and twelve months	
	99	Not applicable (not included in filter)	
	Blank	Unknown	
209	PHYSRISK	<b>Exposure to physical health risk factors</b> <i>Exposure at work to one of the following risk factors that can affect physical health. Identify the factor considered to be the most risky for the physical health</i>	WSTATOR = 1, 2
	0	None of the list below	
	1	Yes, mainly to difficult work postures or work	
	2	Yes, mainly to handling of heavy loads	
	3	Yes, mainly to noise or strong vibration	
	4	Yes, mainly to chemicals, dust, fumes, smoke or gases	
	5	Yes, mainly to activities involving strong visual concentration	
	6	Yes, mainly to risk of accidents	
	9	Not applicable (not included in filter)	
	Blank	Unknown	

**Specifications of the 2013 ad hoc module accidents at work and other health related problems, cont'd.**

210	MENRISK	<p><b>Exposure to mental health risk factors</b>  <i>Exposure at work to one of the following risk factors that can affect mental health. Identify the factor considered to be the most risky for the mental health</i></p> <p>0 None of the list below            1 Yes, mainly to severe time pressure or overload of work            2 Yes, mainly to violence or threat of violence            3 Yes, mainly to harassment or bullying            9 Not applicable (not included in filter)            Blank Unknown</p>	WSTATOR = 1, 2
211/216	COEFF_13	<p><b>AHM weighting factor</b>  <i>Specific weighting factor for the 2013 ad hoc module in case of sub-sampling</i></p> <p>0000-9999 Columns 211-214 contains whole numbers            00-99 Columns 215-216 contains decimal places</p>	

AWNUMBR Accidents at work in the last 12 months (Eurostat AHM 2013 Col 197)

Start date: Jan 2013  
End date: Dec 2013

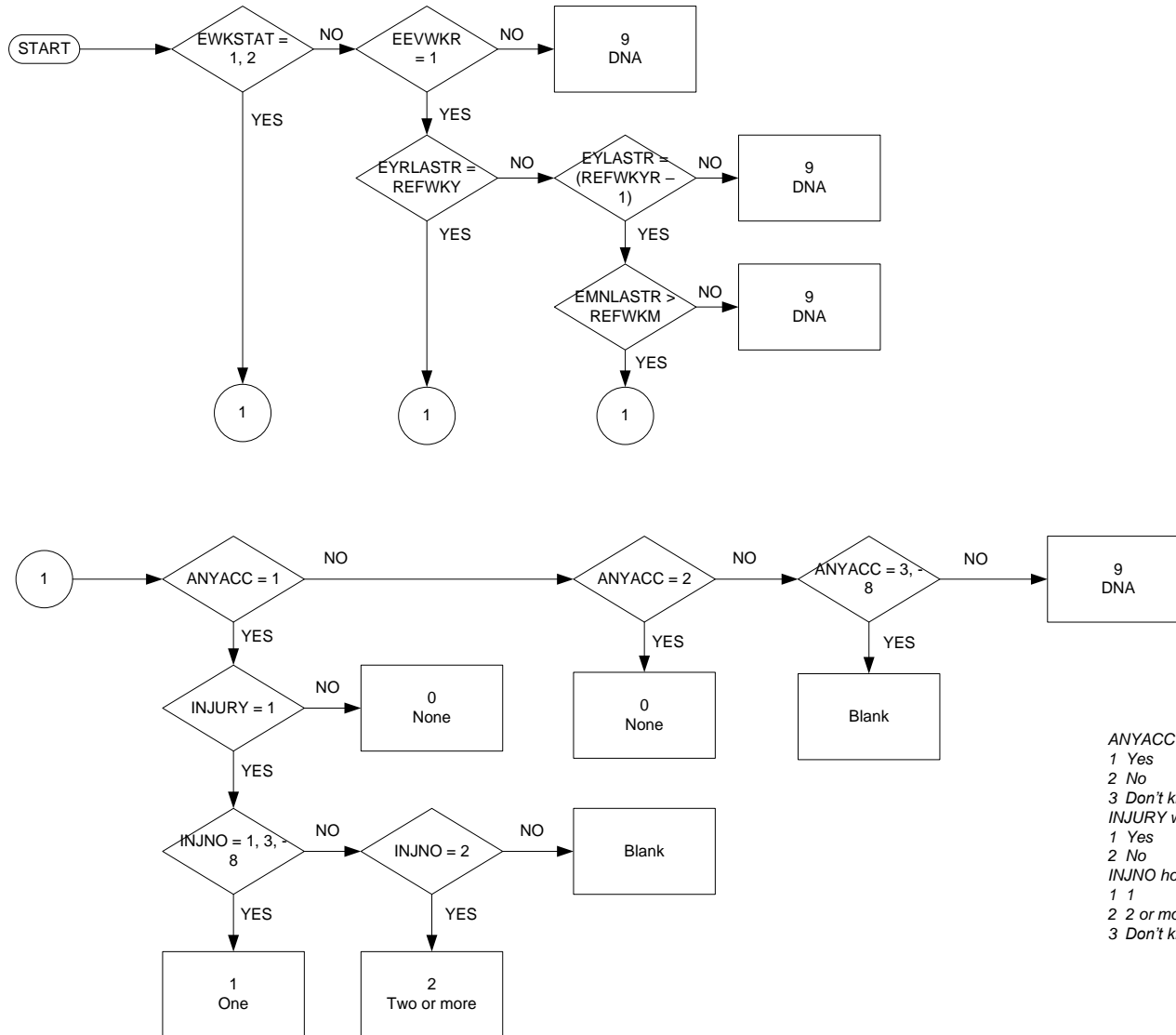

AWROAD Type of accident at work (Eurostat AHM 2013 Col 198)

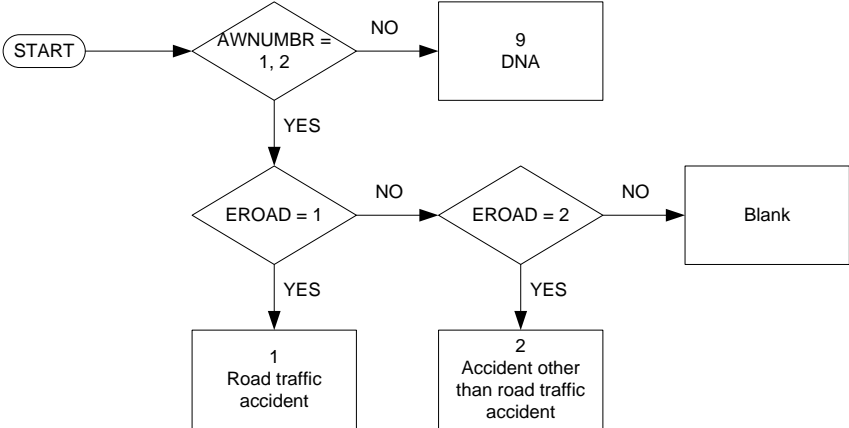

*EROAD whether accident a road accident*  
1 Yes  
2 No

AWJOB Job done when most recent accident at work happened (Eurostat AHM 2013 Col 199)

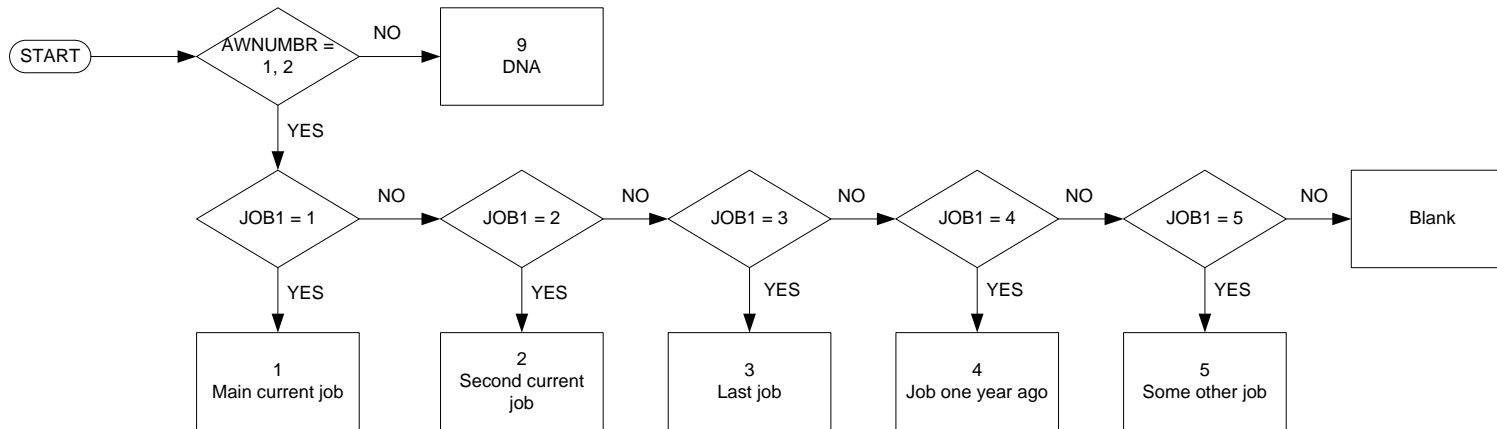

*JOB1 what was the job done when most recent accident happened*  
 1 Main current job  
 2 Second current job  
 3 Last job  
 4 Job one year ago  
 5 Some other job

AWDOFF – Period off work because of accident (Eurostat AHM 2013 Cols 200-201)

Start date: Jan 2013  
End date: Dec 2013

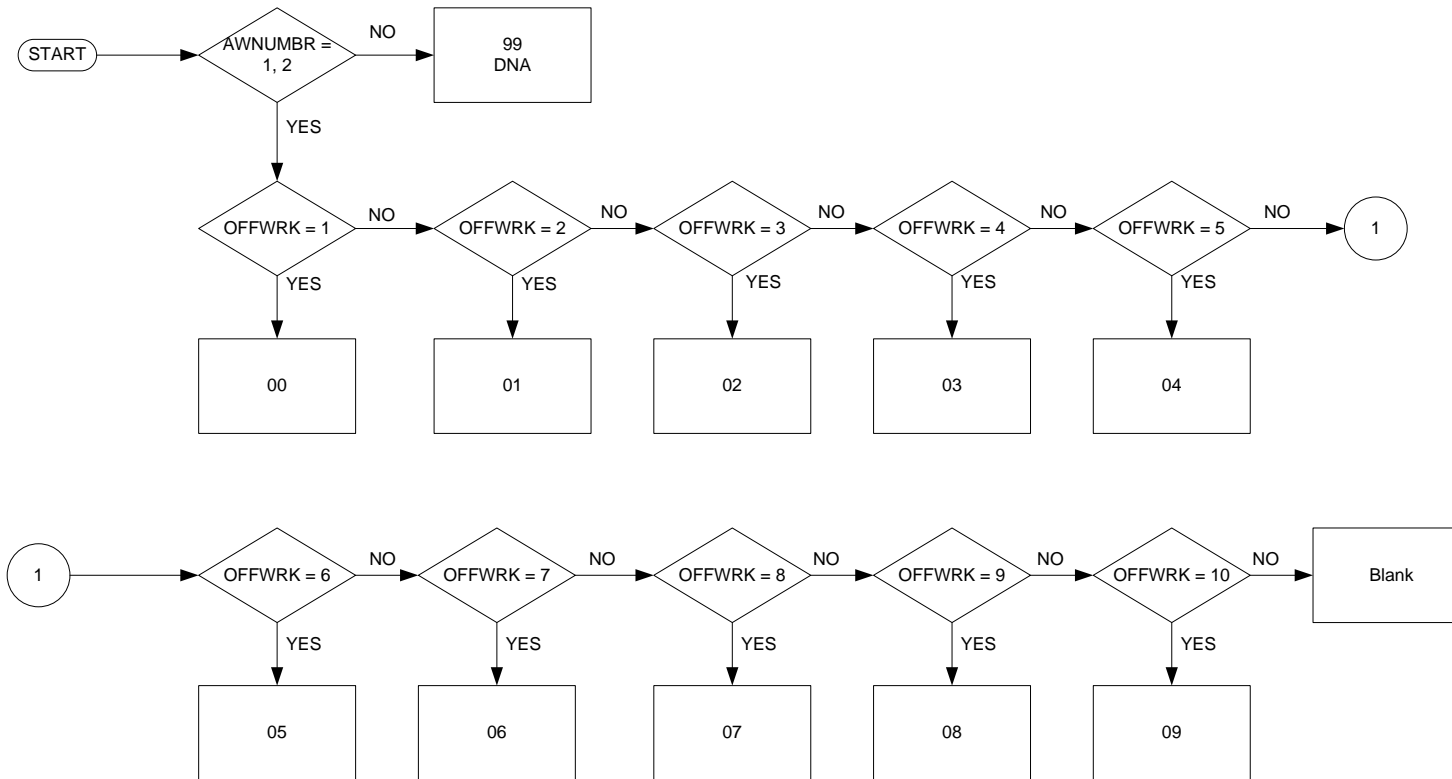

- Key
- 00 Still off work because has not yet recovered from the accident, but expects to resume work later
  - 01 Expects never to work again because of this accident
  - 02 Less than one day or no time off
  - 03 At least one day but less than four days
  - 04 At least four days but less than two weeks
  - 05 At least two weeks but less than one month
  - 06 At least one month but less than three months
  - 07 At least three months but less than six months
  - 08 At least six months but less than nine months
  - 09 Between nine and twelve months
  - 99 Not applicable (not included in filter)

WHPNUMBR Work related health problems (Eurostat AHM 2013 Col 202)

Start date: Jan 2013  
End date: Dec 2013

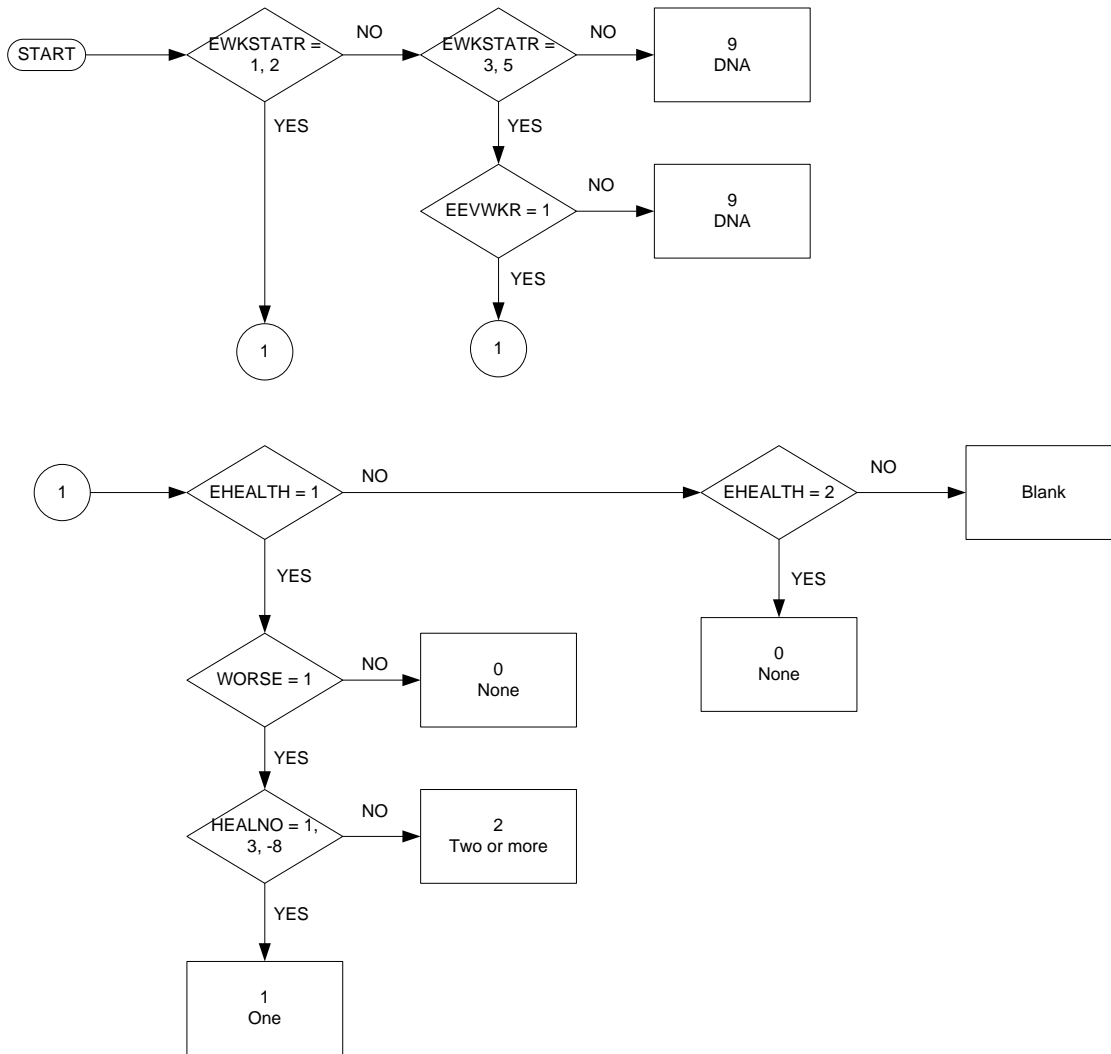

*EWKSTATR* Labour status during reference week  
(WSTATOR col. 24)

- 1 Did any work for pay or profit
- 2 Not working but had a job
- 3 Not working because on lay-off
- 5 Other, neither worked nor had job

*EEVWKR* Existence of previous employment experience  
(EXISTPR col. 84)

- 0 Person has never been in employment
- 1 Person has already been in employment

*EHEALTH* [Apart from accident] within the last 12 months have you suffered from any physical or mental health problems?

- 1 Yes
- 2 No
- 3 Don't know

*WORSE* Were any of these health problems caused or made worse by your job or by work you have done in the past?

- 1 Yes
- 2 N
- 3 Don't know

*HEALNO* How many health problems in the last 12 months have been caused or made worse by your work?

- 1 One
- 2 Two or more
- 3 Don't know



WHTYPEP Type of work related health problems (Eurostat AHM 2013 Cols 203-204)

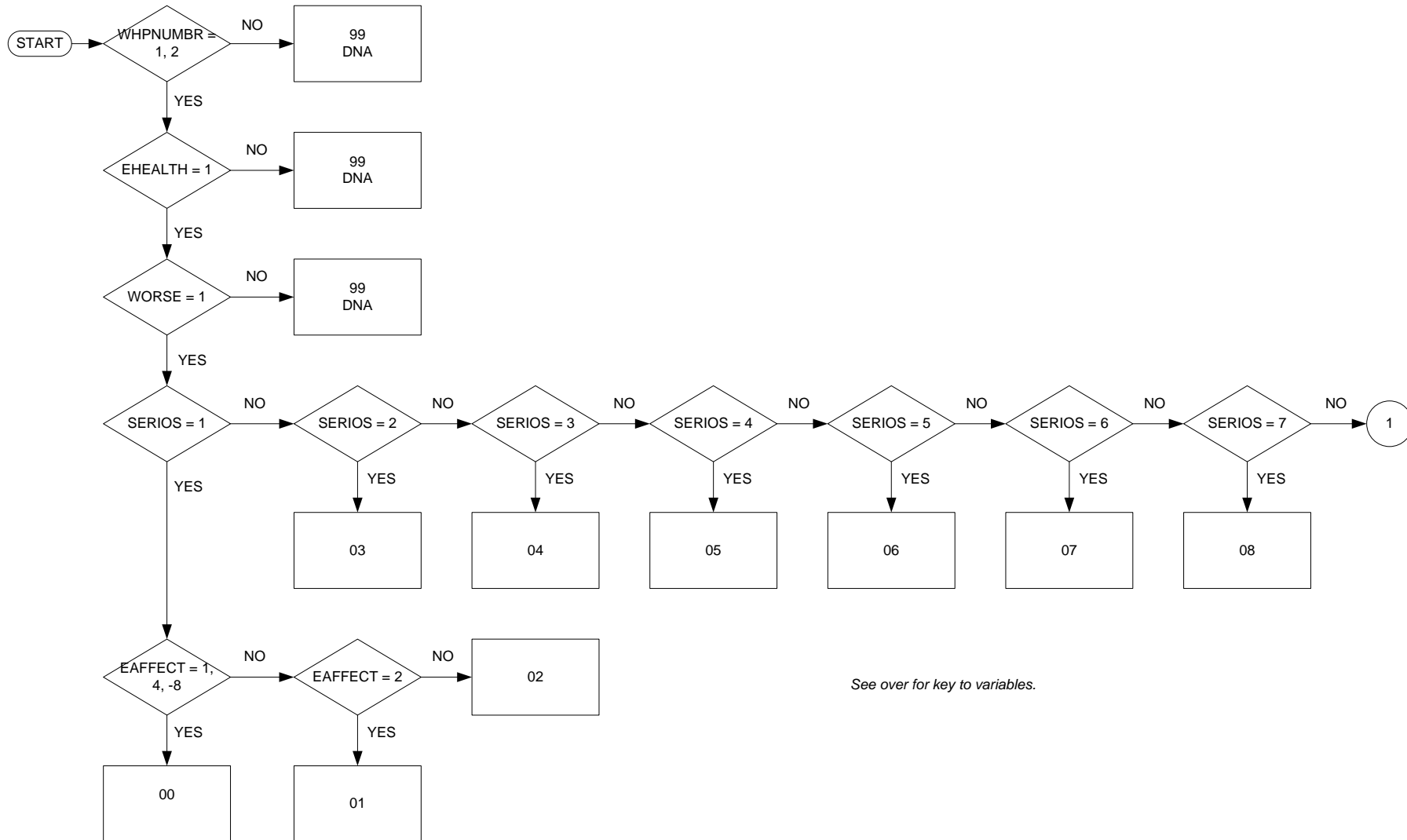

WHTYPEP Type of work related health problems (Eurostat AHM 2013 Cols 203-204)

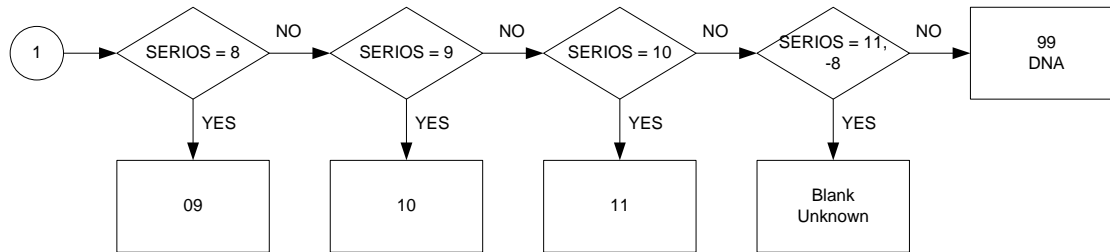

Key:  
WHTYPEP Type of work related health problem  
00 Bone, joint or muscle problem mainly affecting neck, shoulders, arms or hands  
01 Bone, joint or muscle problem mainly affecting hips, kness, legs or feet  
02 Bone, joint or muscle problem mainly affecting back  
03 Breathing or lung problem  
04 Skin problem  
05 Hearing problem  
06 Stress, depression or anxiety  
07 Headache and/or eyestrain  
08 Heart disease or attack or other circulatory system problem  
09 Infectious diseases (virus, bacteria or other infection)  
10 Stomach, liver, kidney or other digestive problem  
11 Other types of health problem

Subordinate variables key:

*EHEALTH [Apart from accident] within the last 12 months have you suffered from any physical or mental health problems?*

- 1 Yes
- 2 No
- 3 Don't know

*WORSE Were any of these health problems caused or made worse by your job or by work you have done in the past?*

- 1 Yes
- 2 Do
- 3 Don't know

*SERIOS How would you describe this health problem?*

- 1 Bone, joint or muscle problem
- 2 Breathing or lung problem
- 3 Skin problem
- 4 Hearing problem
- 5 Stress, depression or anxiety
- 6 Headache and/or eyestrain
- 7 Heart disease or attack or other circulatory system problem
- 8 Infectious diseases (virus, bacteria or other infection)
- 9 Stomach, liver, kidney or other digestive problem
- 10 Other types of health problem
- 11 Don't know

*EAEFFECT Bone, joint or muscle problem mainly affects...*

- 1 Neck, shoulders, arms or hands
- 2 Hips, knees, legs or feet
- 3 Back
- 4 Don't know

WHPLIMAB Health problem limiting daily activities (Eurostat AHM 2013 Col 205)

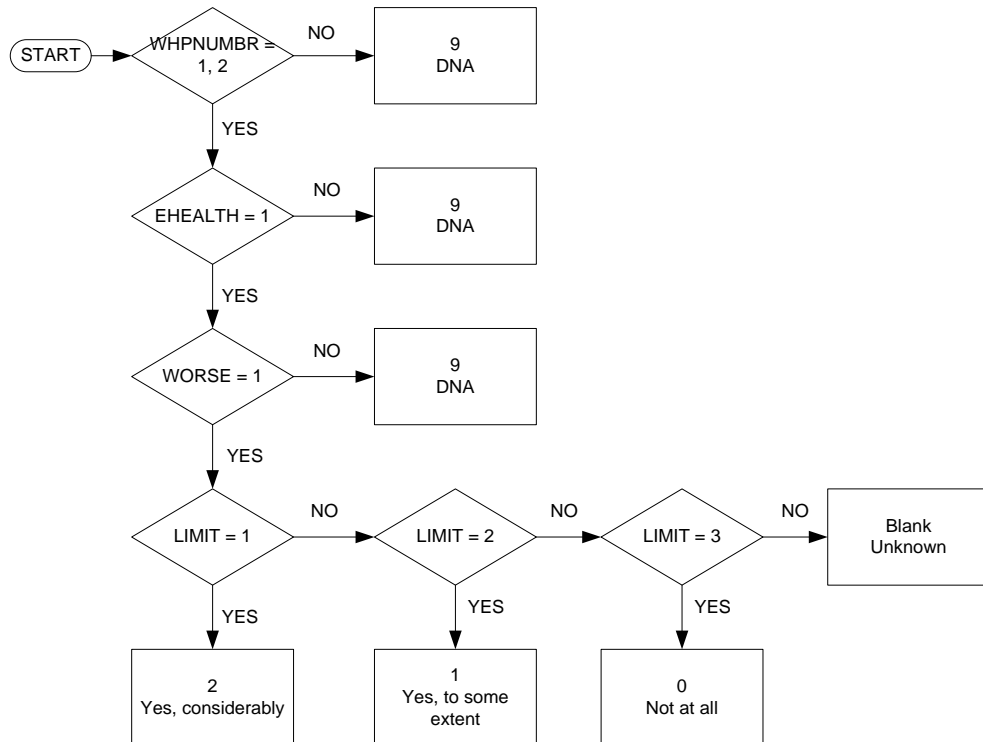

*EHEALTH* [Apart from accident] within the last 12 months have you suffered from any physical or mental health problems?

- 1 Yes
- 2 No
- 3 Don't know

*WORSE* Were any of these health problems caused or made worse by your job or by work you have done in the past?

- 1 Yes
- 2 No
- 3 Don't know

*LIMIT* Whether health problem limits ability to carry out day to day activities either at work or away from work

- 1 Considerably
- 2 To some extent
- 3 Not at all

WHPJOB Job of health problem (Eurostat AHM 2013 Col 206)

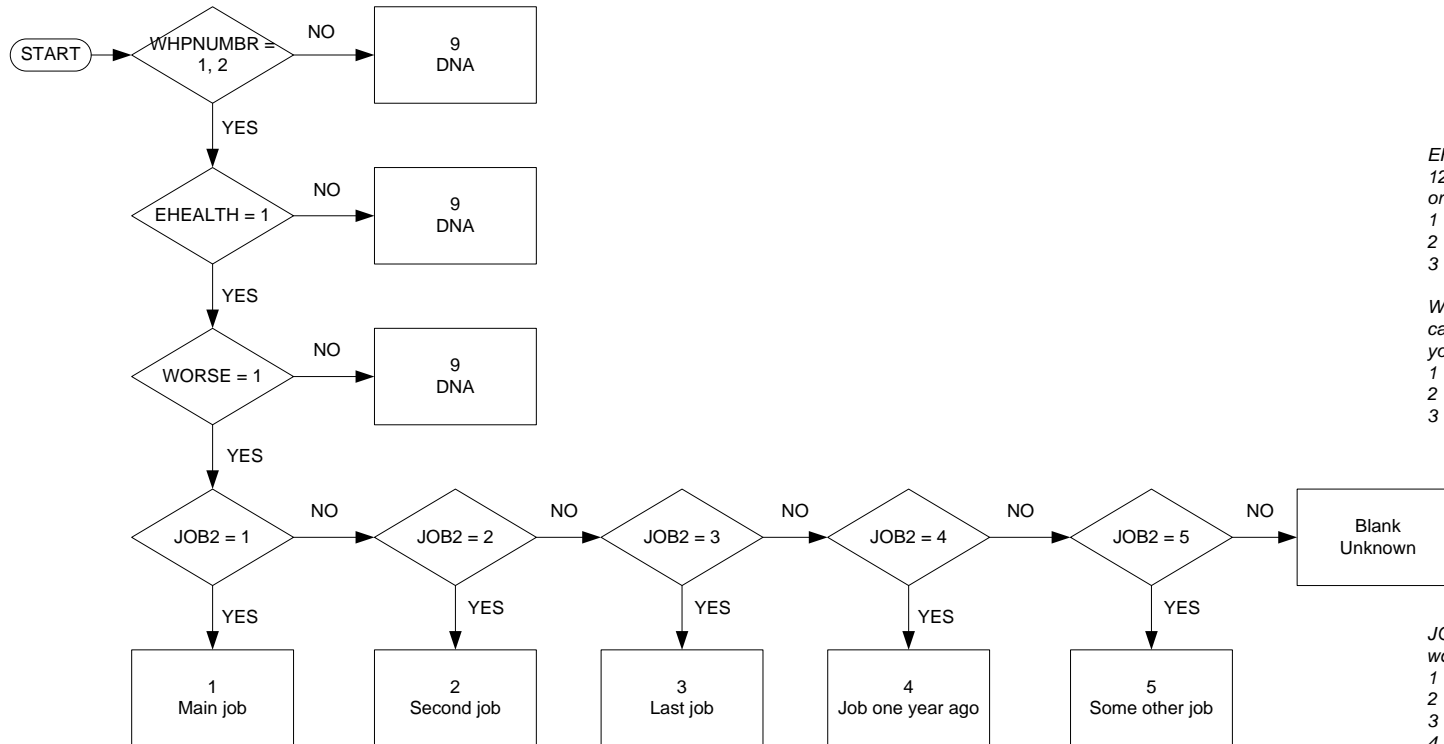

*EHEALTH [Apart from accident] within the last 12 months have you suffered from any physical or mental health problems?*  
 1 Yes  
 2 No  
 3 Don't know

*WORSE Were any of these health problems caused or made worse by your job or by work you have done in the past?*  
 1 Yes  
 2 No  
 3 Don't know

*JOB2 Job that caused or made health problem worse was...*  
 1 Main job  
 2 Second job  
 3 Last job  
 4 Job one year ago  
 5 Some other job  
 6 Don't know

WHPDOFF Period off work because of health problem (Eurostat AHM 2013 Cols 207-208)

Start date: Jan 2013  
End date: Dec 2013

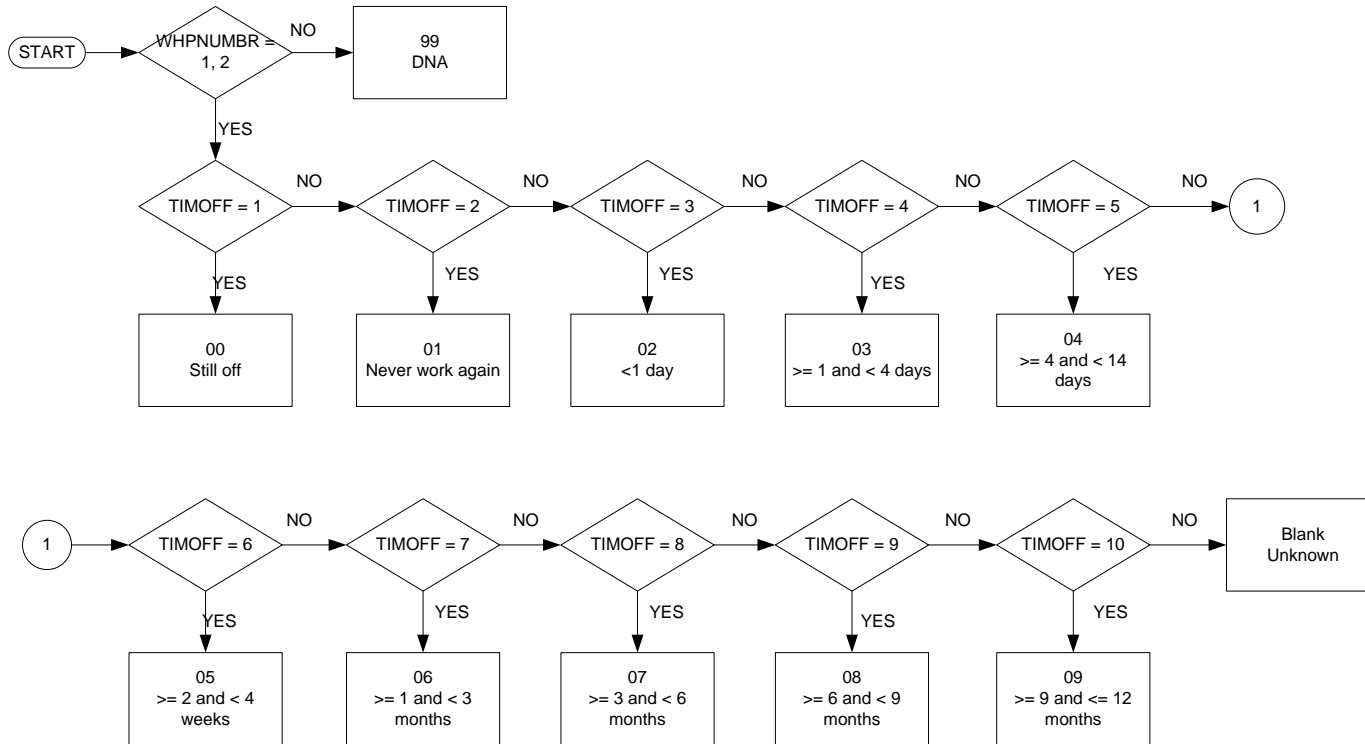

Key  
WHPDOFF  
00 Still off work because not yet recovered from health problem, but expects to resume work later  
01 Expects never to work again because of this health problem  
02 Less than one day or no time off  
03 At least one day but less than four days  
04 At least four days but less than two weeks  
05 At least two weeks but less than one month  
06 At least one month but less than three months  
07 At least three months but less than six months  
08 At least six months but less than nine months  
09 Between nine and twelve months  
99 Not applicable

PHYSRISK Exposure to physical health risk factors (Eurostat AHM 2013 Col 209)

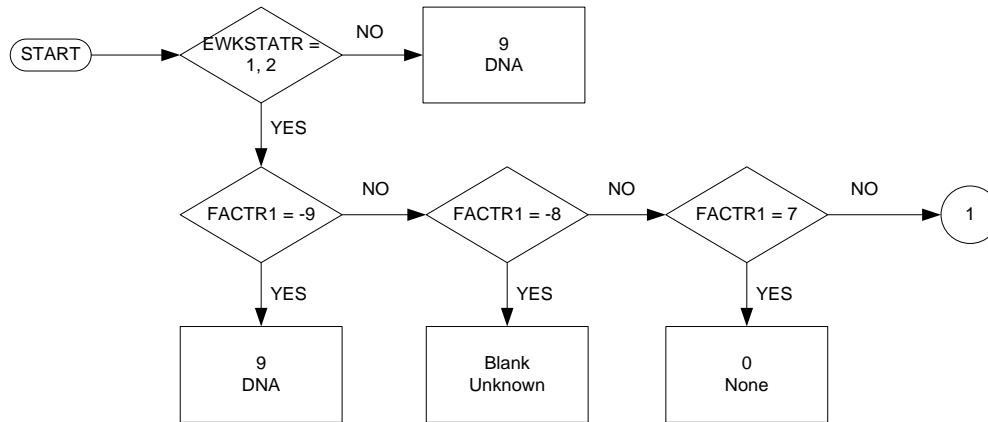

*FACTR* Would you say that at work you are exposed to the following factors that could affect your physical health

- 1 Difficult work postures or work movements
- 2 Handling of heavy loads
- 3 Noise or strong vibrations
- 4 Chemicals, dust, fumes, smoke or gases
- 5 Activities involving strong visual concentration
- 6 Risk of accidents
- 7 None of these

*FACTRM* Main factor exposed to that could affect physical health

- 1 Difficult work postures or work movements
- 2 Handling of heavy loads
- 3 Noise or strong vibrations
- 4 Chemicals, dust, fumes, smoke or gases
- 5 Activities involving strong visual concentration
- 6 Risk of accidents
- 7 None of these

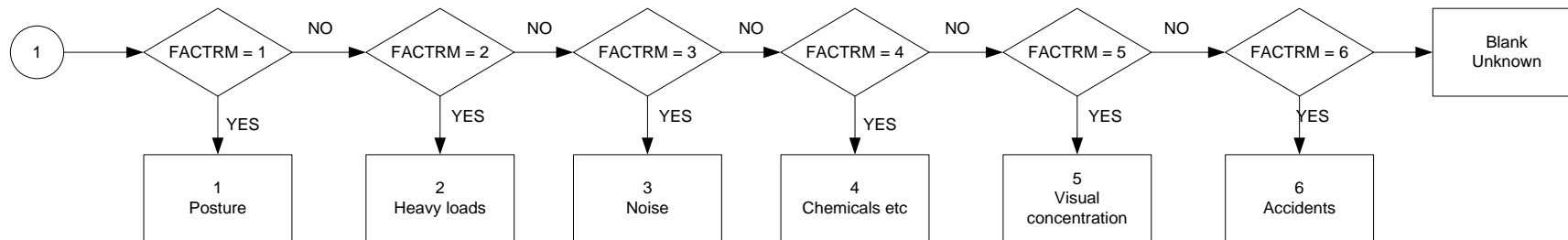

Key  
PHYSRISK Exposure to physical health risk factors  
1 Difficult work postures or work movements  
2 Handling of heavy loads  
3 Noise or strong vibrations  
4 Chemicals, dust, fumes, smoke or gases  
5 Activities involving strong visual concentration  
6 Risk of accidents  
9 Not applicable

MENTRISK Exposure to mental well-being risk factors (Eurostat AHM 2013 Col 210)

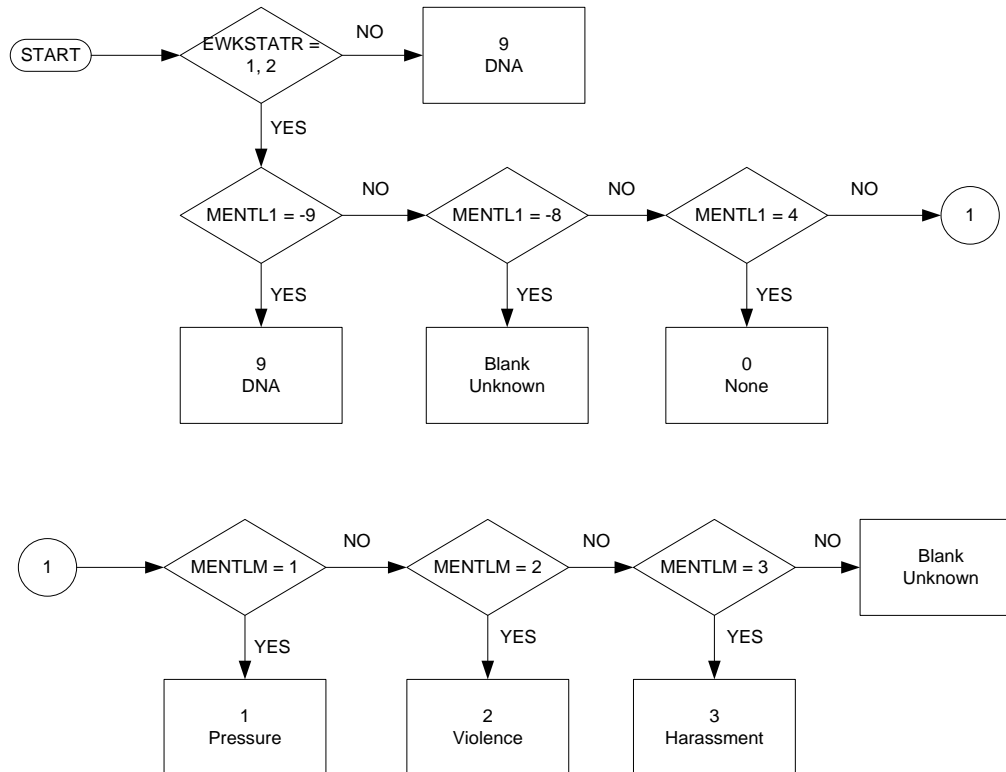

*MENTL* Would you say that at work you are exposed to the following factors that could affect your mental well-being

- 1 Severe time pressure or overload of work
- 2 Violence or threat of violence
- 3 Harassment or bullying
- 4 None of these

*MENTLM* Which of these factors do you consider to be the greatest risk to your mental well-being

- 1 Severe time pressure or overload of work
- 2 Violence or threat of violence
- 3 Harassment or bullying
- 4 None of these

Key  
MENTRISK Exposure to mental well-being risk factors  
0 None of the list below  
1 Mainly to severe time pressure or overload of work  
2 Mainly to violence or threat of violence  
3 Mainly to harassment or bullying  
9 Not applicable

## EXPLANATORY NOTES

### LFS Ad hoc module 2013 on Accidents at work and other work related health problems

AWNUMBR	197	<b>Accidents at work in the last 12 months</b> <i>Accidents at work resulting in injuries occurred in the 12 months before the reference week.</i>	(WSTATOR=1,2) or (WSTATOR=3-5 and EXISTPR=1 and YEARPR and MONTHPR is not prior to 1 year before the reference week)
	0	None	
	1	One	
	2	Two or more	
	9	Not applicable (not included in the filter)	
	Blank	Unknown	

#### Filters

Everybody aged 15 or more and who is working (WSTATOR = 1, 2) or has worked during the past 12 months (EXISTPR = 1 and YEARPR and MONTHPR is not prior to one year before the end of the reference week).

#### Objective

The aim is to know if the person has had an accident at work during the past 12 months that resulted in an injury or injuries, and if yes, how many accidents at work he/she had during that period of time. The concept of those accidents is aligned to the definition in ESAW (European Statistics Accidents at Work) to permit a comparison<sup>1</sup>.

#### Definition

An accident at work resulting in injuries is a discrete and unforeseen event or occurrence which leads to physical harm to the respondent and that occurred whilst engaged in an occupational activity or during the time spent at work.

#### Details and instructions

##### Inclusions:

- An accident at work resulting in injuries which did not lead to a sick leave is also included.
- An accident at work resulting in injuries which did not need a medical treatment is also included.
- Any accident occurred during working time, even if it has not occurred during the usual work or in the usual workplace of the person, has to be taken into consideration.

<sup>1</sup> The only exception is accidents which lead to mental harm; those are included in ESAW. However because the distinction between a discrete occurrence leading to mental harm and a mental health problem caused or made worse by work is difficult to make and because the difficulties experienced in the LFS 2007 ad-hoc module on understanding and difference in practices across countries, the decision was taken for the LFS 2013 version to drop the accidents leading to mental harm.



- From this follows that, during work, all types of accidents in a public place or means of transport, either if it is the usual workplace or during a journey in the course of work, should be considered as an accident at work. So, the following types of accidents are included: road traffic accidents in the course of work; slips, falls, aggressions, etc., in public places (pavement, staircases, etc.) or in the arrival and starting points (station, port, airport, etc.) of any means of transport occurred in the course of work; accidents on board of any means of transport used in the course of work (underground railway, tram, train, boat, plane, etc.), accidents occurring during a mission done for work (even if the person leaves for a mission directly from home) and accidents occurred in the course of work within the premises of another company than the one which employs the victim.
- Accidents at lunch time, or any other break, inside the premises of the enterprise should also be included.
- The concept of an accident includes also cases of acute poisoning and wilful acts by other persons.

### Exclusions:

from the above definitions the following types of accidents are excluded:

- accidents occurred in the course of travelling between home and the workplace (commuting accidents);
- accidents occurred in the course of travelling between the workplace and the place of meals, whether it is at home or in a restaurant outside the premises of the enterprise;
- accidents in which the respondent was an observer or was involved without having a personal injury; for example a truck driver involved in an accident at the road but without physical harm for himself;
- home and leisure accidents;
- road traffic or transport accidents in the course of private activities;
- occupational diseases and other health problems which develop over a long time. In some rare cases it may be difficult to make a difference. For example if a health care worker has a needle stick injury and develops an infectious disease as a consequence, the onset is accidental and the needle stick injury should be considered as an accident. If a construction worker injures his back as a consequence of a sudden movement, it should be considered as an accident. While if a back pain develops over one day when he was carrying heavy loads, it should be seen as a non-accidental work-related health problem.
- deliberate self-inflicted injuries.

When the person suffered more than one accident at work during the 12 months reference period, the code “2 - two or more” has to be used.

An accident resulting in multiple injuries is counted once.

The 12 months reference period includes the reference week (for example: accidents between the 15 April N-1 and the 14 April N for a reference week ending on 14 April N).

**Specifications of the 2012 ad hoc module on transition from work to retirement**

Column	Code	Description	Filters/remarks
197	PENSION 1 2 9 Blank	<i>Person receives a pension</i> Yes No Not applicable (not included in filter) No answer or does not know	Everybody aged 50 69 and (WSTATOR = 1, 2 or (WSTATOR = 3, 5 and (YEARPR- YEARBIR) > 49))
198/205	PENSTYPE PENSTYP1 PENSTYP2 PENSTYP3 PENSTYP4 PENSTYP5 PENSTYP6 PENSTYP7 PENSTYP8 99999999	<i>Because of the health condition(s)/disease(s) or activity difficulty(ies)</i> 1: Yes; 2: No. Old-age pension. Statutory scheme 1: Yes; 2: No. Old-age pension. Occupational scheme 1: Yes; 2: No. Old-age pension. Personal scheme 1: Yes; 2: No. Old-age pension. Scheme unknown 1: Yes; 2: No. Unemployment pension 1: Yes; 2: No. Disability pension 1: Yes; 2: No. Survivor's pension 1: Yes; 2: No. Other pension(s) or type of pension unknown Not applicable (not included in filter)	PENSION = 1
206	EARLYRET 1 2 9 Blank	<i>Early retirement</i> Yes No Not applicable (not included in filter) No answer	PENSTYP1 = 1 or PENSTYP2 = 1 or PENSTYP3 = 1 or PENSTYP4 = 1
207/208	AGEPENS 99 Blank	<i>Age at which person first received an old- age pension</i> Two digits Not applicable (not included in filter) No answer or does not know	PENSTYP1 = 1 or PENSTYP2 = 1 or PENSTYP3 = 1 or PENSTYP4 = 1
209	REASNOT 1 2 3 4 5 6 7 8 9 Blank	<i>Main reason for not staying longer at work</i> 1 Favourable financial arrangements to leave 2 Lost job and/or could not find a job 3 Had reached the maximum retirement age 4 Had reached eligibility for a pension 5 Other job-related reasons 6 Own health or disability 7 Family or care related reasons 8 Other 9 Not applicable (not included in filter) No answer or does not know	WSTATOR = 3, 5 and SEEKWORK = 3 and PENSION = 1
210	WORKLONG 1 2 9 Blank	<i>Wish to stay longer at work</i> Yes No Not applicable (not included in filter) No answer or does not know	WSTATOR = 3, 5 and SEEKWORK = 3 and PENSION = 1

## Specifications of the 2012 ad hoc module on transition from work to retirement, cont'd

Column	Code	Description	Filters/remarks
211	REDUCHRS	<i>Person reduced working hours in a move towards full retirement</i>	(WSTATOR = 1, 2 and aged 55-69) or (WSTATOR = 3, 5 and SEEKWORK = 3 and PENSION = 1)
	1	Yes, before receiving the first old-age pension	
	2	Yes, since or after receiving the first old-age pension	
	3	No	
	9	Not applicable (not included in filter)	
	Blank	No answer or does not know	
212	STAYWORK	<i>Main reason for staying at work</i>	WSTATOR = 1, 2 and PENSION = 1
	1	To establish or increase future retirement pension entitlements	
	2	To provide sufficient personal/household income	
	3	Combination of 1 and 2	
	4	Non-financial reason, e.g. work satisfaction	
	9	Not applicable (not included in filter)	
	Blank	No answer	
213	PLANSTOP	<i>Plans to stop work</i>	WSTATOR = 1, 2 and PENSION = 1
	1	In up to 1 year	
	2	In more than 1 year, up to 3 years	
	3	In more than 3 years, up to 5 years	
	4	In more than 5 years, up to 10 years	
	5	More than 10 years	
		9	
	Blank	No answer or does not know	
214/217	BUILDPEN	<i>Pension rights built up so far</i>	PENSION = 2, blank or (PENSTYP1 to PENSTYP4 = 0)
	BUILDPEN1	1: Yes; 2: No. Old-age pension. Statutory scheme	
	BUILDPEN2	1: Yes; 2: No. Old-age pension. Occupational scheme	
	BUILDPEN3	1: Yes; 2: No. Old-age pension. Personal scheme	
	BUILDPEN4	1: Yes; 2: No. Old-age pension. Scheme unknown	
	9999	Not applicable (not included in filter)	
218	CONTRWORK	<i>Expects to continue working/looking for a job after receiving old age pension</i>	(WSTATOR = 1, 2 or (WSTATOR = 3, 5 and SEEKWORK = 1, 2, 4)) and BUILDPEN ≠ 0000, 9999 and PENSION = 2, blank
	1	Yes, for financial reasons	
	2	Yes, for other reasons	
	3	No, stop immediately when receiving old-age pension	
	4	No, stop before receiving old-age pension	
		9	
	Blank	No answer or does not know	
219/224		<i>Weighting factor for the 2012 ad hoc module (optional)</i>	Everybody aged 50-69 and (WSTATOR = 1, 2 or (WSTATOR = 3, 5 and (YEARPR-YEARBIR) > 49))
	0000 – 9999	Columns 213-216 contain whole numbers	
	00 – 99	Columns 217-218 contain decimal places	

EPENSION Person receives a pension (Eurostat AHM 2012 Col 197)

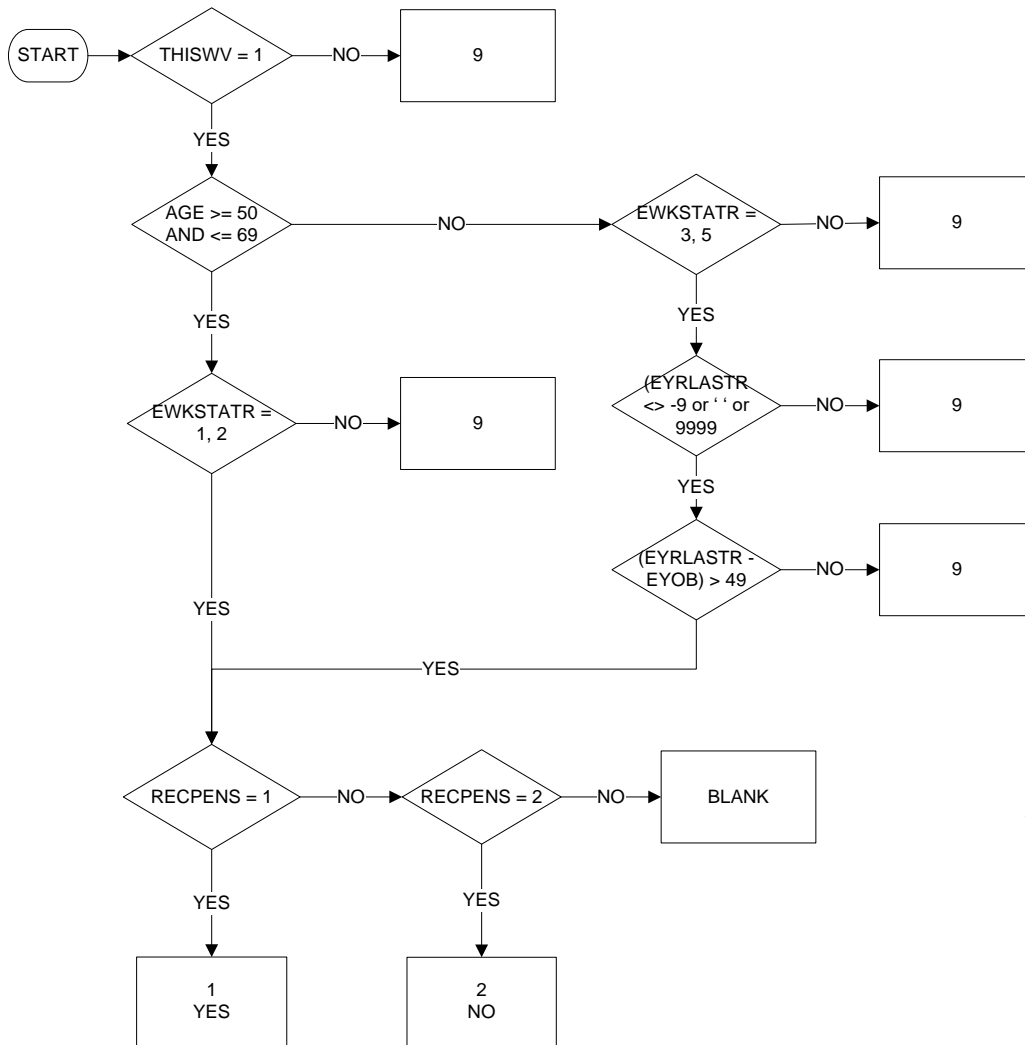

RECPENS Do you currently receive regular payments from a pension  
1 Yes  
2 No

EPENSTYP1 Type of pension – Old age pension. Statutory scheme (Eurostat AHM 2012 Col 198)

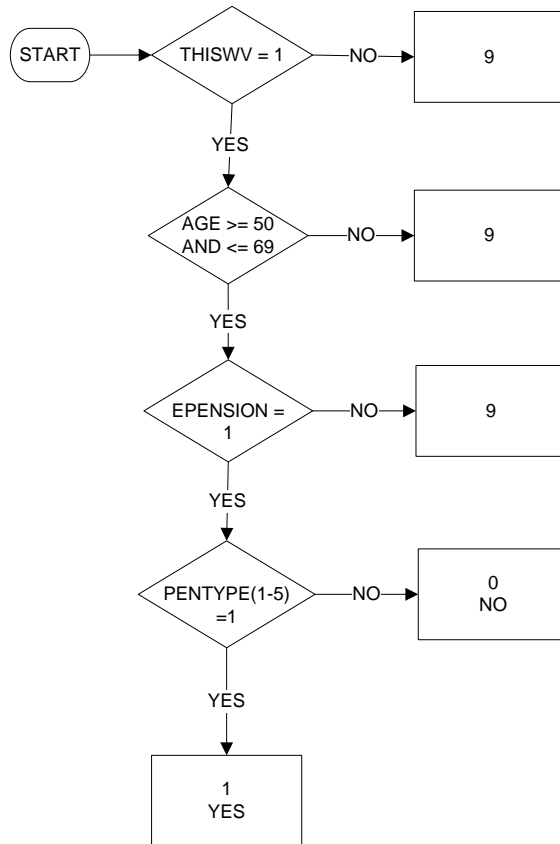

*PENTYPE Do you currently receive a...*  
 1 State Pension  
 2 Pension on an Occupational Scheme  
 3 Pension on a Personal Scheme  
 4 Survivor's/Widower's Pension  
 5 Other Pension(s)

EPENSTYP2 Type of pension – Old age pension. Occupational scheme (Eurostat AHM 2012 Col 199)

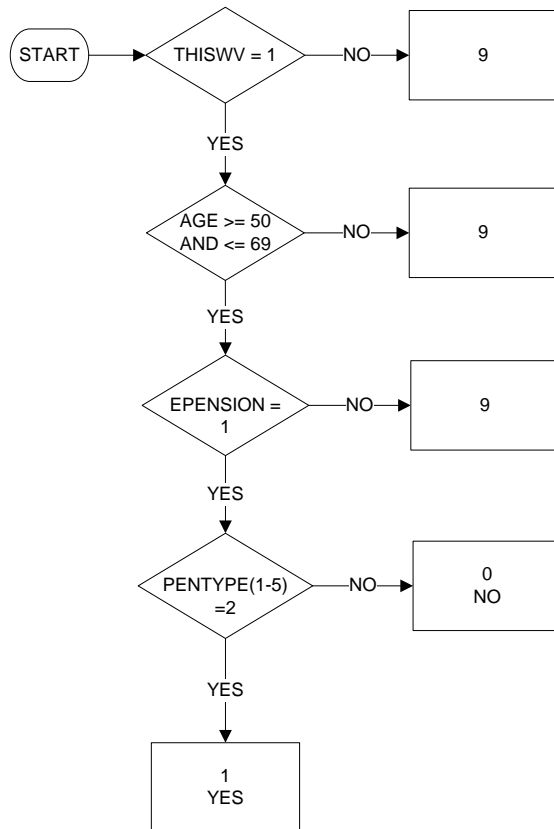

*PENTYPE Do you currently receive a...*  
 1 State Pension  
 2 Pension on an Occupational Scheme  
 3 Pension on a Personal Scheme  
 4 Survivor's/Widower's Pension  
 5 Other Pension(s)

EPENSTYP3 Type of pension – Old age pension. Personal scheme (Eurostat AHM 2012 Col 200)

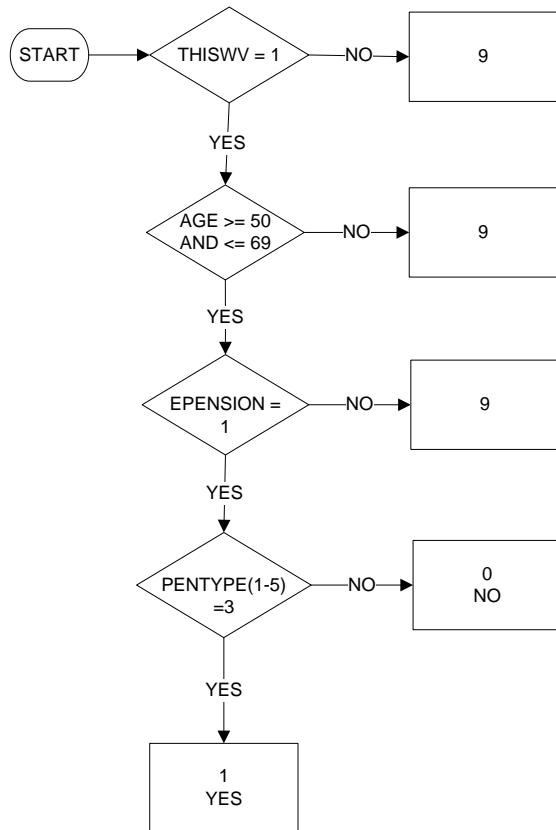

*PENTYPE Do you currently receive a...*  
 1 State Pension  
 2 Pension on an Occupational Scheme  
 3 Pension on a Personal Scheme  
 4 Survivor's/Widower's Pension  
 5 Other Pension(s)

EPENSTYP4 Type of pension – Old age pension. Scheme unknown (Eurostat AHM 2012 Col 201)

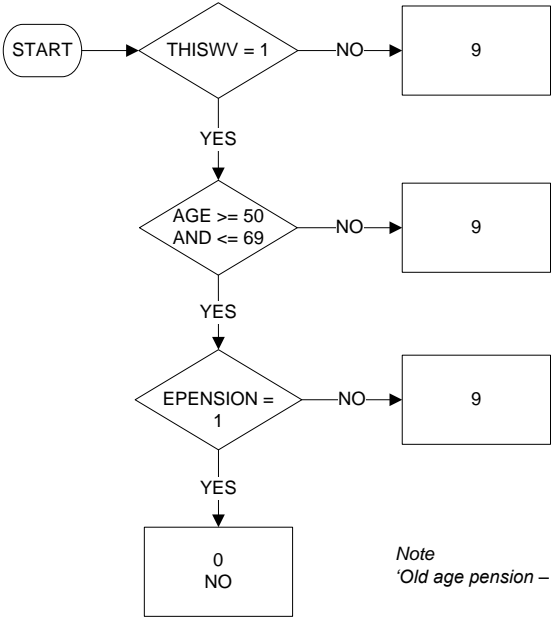

*Note*  
'Old age pension – scheme unknown' not available in UK LFS so all applicable cases set to 'No'



EPENSTYP5 Type of pension – Unemployment pension (Eurostat AHM 2012 Col 202)

Start date: Jan 2012  
End date: Dec 2012

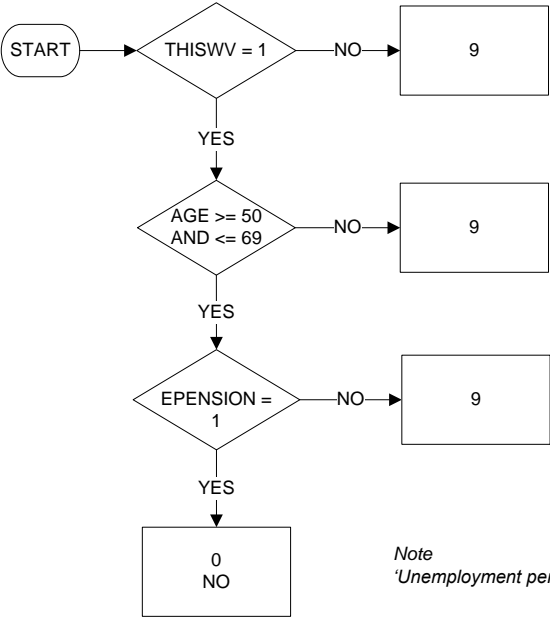

Note  
'Unemployment pension' not available in UK LFS so all applicable cases set to 'No'

EPENSTYP6 Type of pension – Disability pension (Eurostat AHM 2012 Col 203)

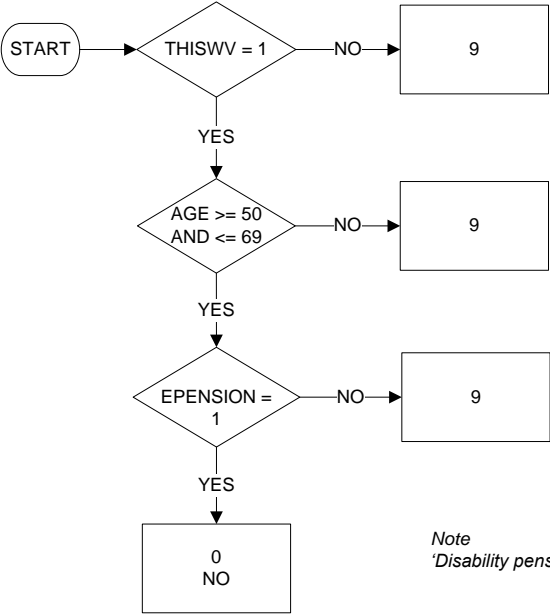

Note  
'Disability pension' not available in UK LFS so all applicable cases set to 'No'

EPENSTYP7 Type of pension – Survivors pension (Eurostat AHM 2012 Col 204)

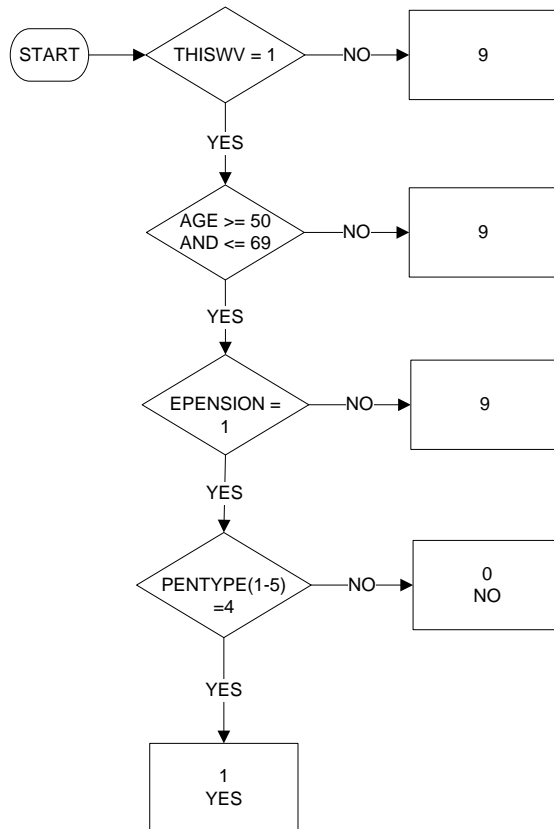

*PENTYPE Do you currently receive a...*  
 1 State Pension  
 2 Pension on an Occupational Scheme  
 3 Pension on a Personal Scheme  
 4 Survivor's/Widower's Pension  
 5 Other Pension(s)

EPENSTYP8 Type of pension – Other pension(s) or type of pension unknown (Eurostat AHM 2012 Col 205)

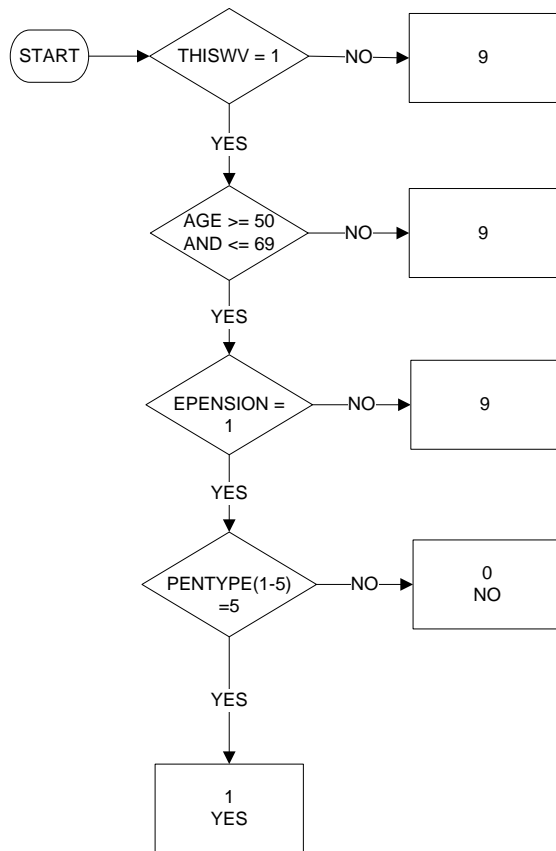

*PENTYPE Do you currently receive a...*  
 1 State Pension  
 2 Pension on an Occupational Scheme  
 3 Pension on a Personal Scheme  
 4 Survivor's/Widower's Pension  
 5 Other Pension(s)

EEARLYRET – Early retirement (Eurostat AHM 2012 Col 206)

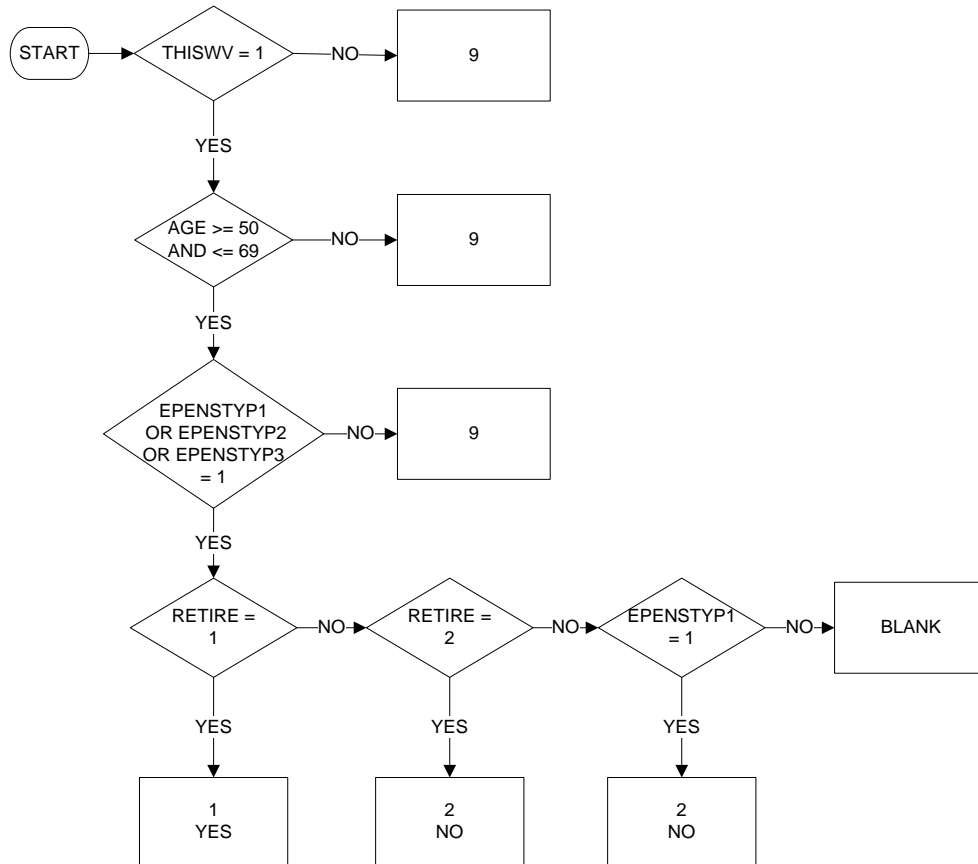

*RETIRE* Do you receive, or have you received, a pension from an early retirement plan  
1 Yes  
2 No

EAGEPENS – Age at which person first received an old-age pension (Eurostat AHM 2012 Col 207-208)

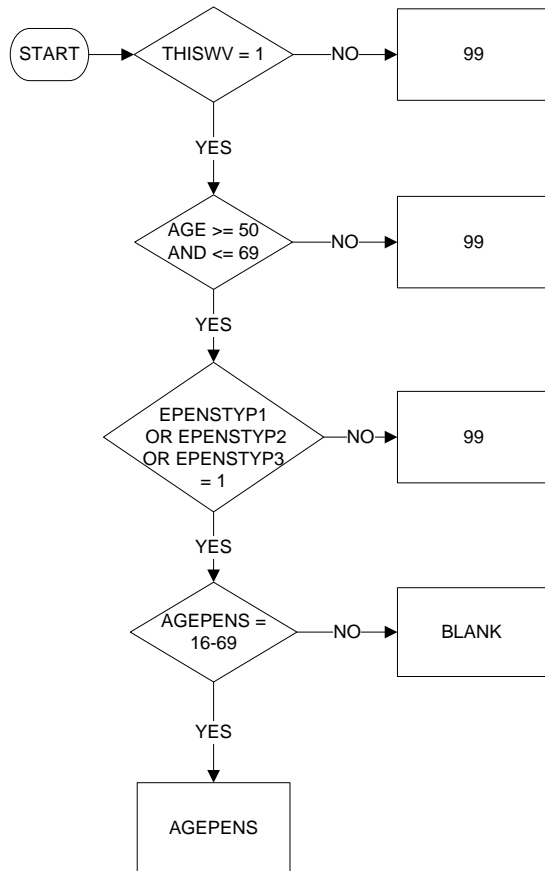

*AGEPENS At what age did you start to receive your (first) pension*

EREASNOT Main reason for not staying longer at work (Eurostat AHM 2012 Col 209)

Start date: Jan 2012  
End date: Dec 2012

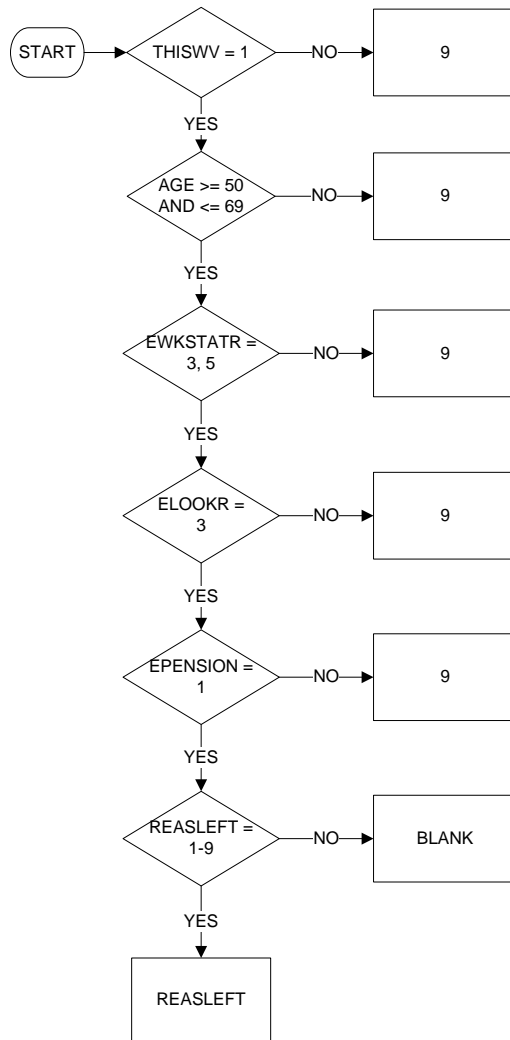

- REASLEFT*
- 1 Favourable financial arrangements to leave
  - 2 Lost job and/or could not find a job
  - 3 Had reached the maximum retirement age
  - 4 Had reached eligibility for a pension
  - 5 Other job-related reasons
  - 6 Own health or disability
  - 7 Family or care related reasons
  - 8 Other
  - 9 Not applicable
- BLANK* No answer or does not know

EWORLONG – Wish to stay longer at work (Eurostat AHM 2012 Col 210)

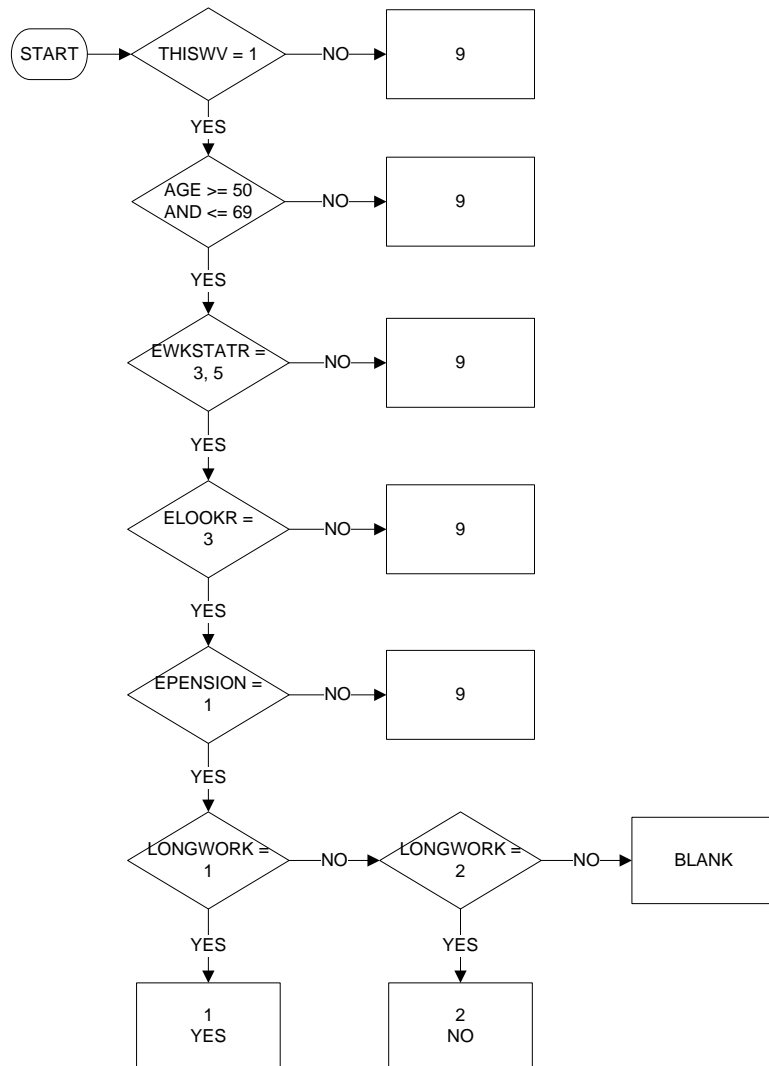

LONGWORK Would you have preferred to stay longer at work  
1 Yes  
2 No



EREDUCHRS Person reduced working hours in a move towards full retirement (Eurostat AHM 2012 Col 211)

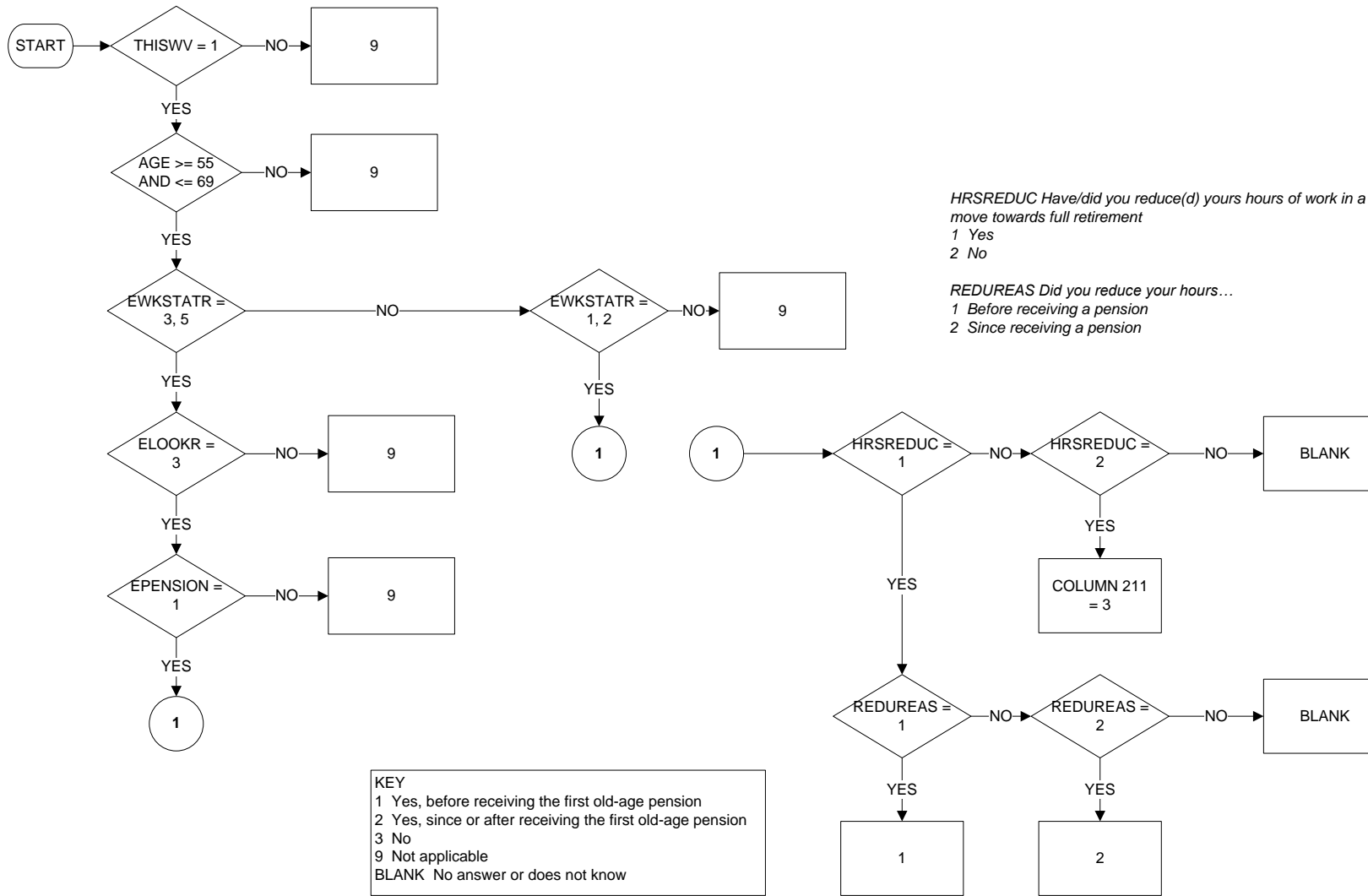

ESTAYWRK - Main reason for staying in work (Eurostat AHM 2012 Col 212)

Start date: Jan 2012  
End date: Dec 2012

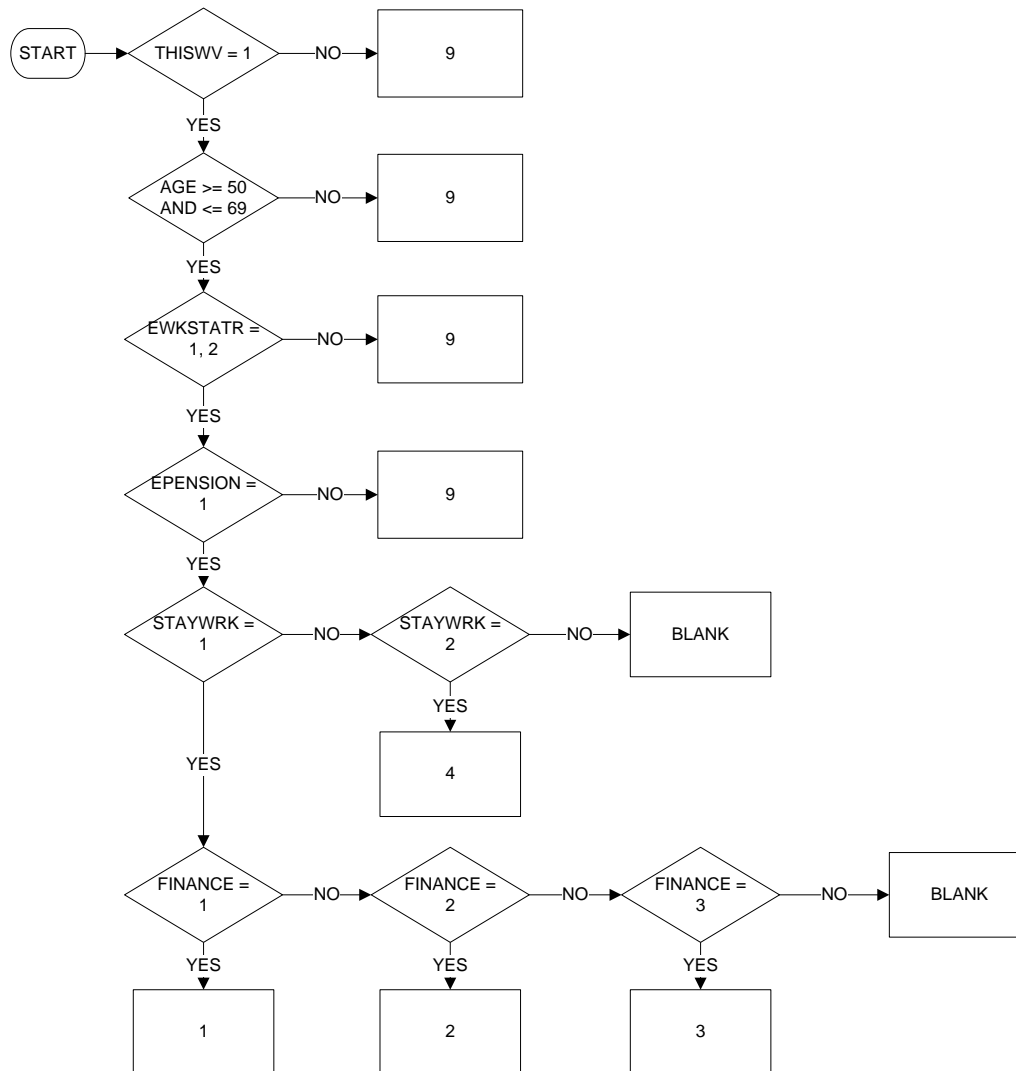

STAYWRK What was your main reason for staying in work...

- 1 Financial reasons
- 2 Other reasons

FINANCE Were these financial reasons...

- 1 To establish or increase future retirement pension
- 2 To provide sufficient personal/household income
- 3 Both

KEY

- 1 To establish or increase future retirement entitlements
- 2 To provide sufficient personal/household income
- 3 Combination of 1 and 2
- 4 Non-financial reasons, e.g. work satisfaction
- 9 Not applicable
- BLANK No answer or does not know

EPLANSTOP Plans to stop work (Eurostat AHM 2012 Col 213)

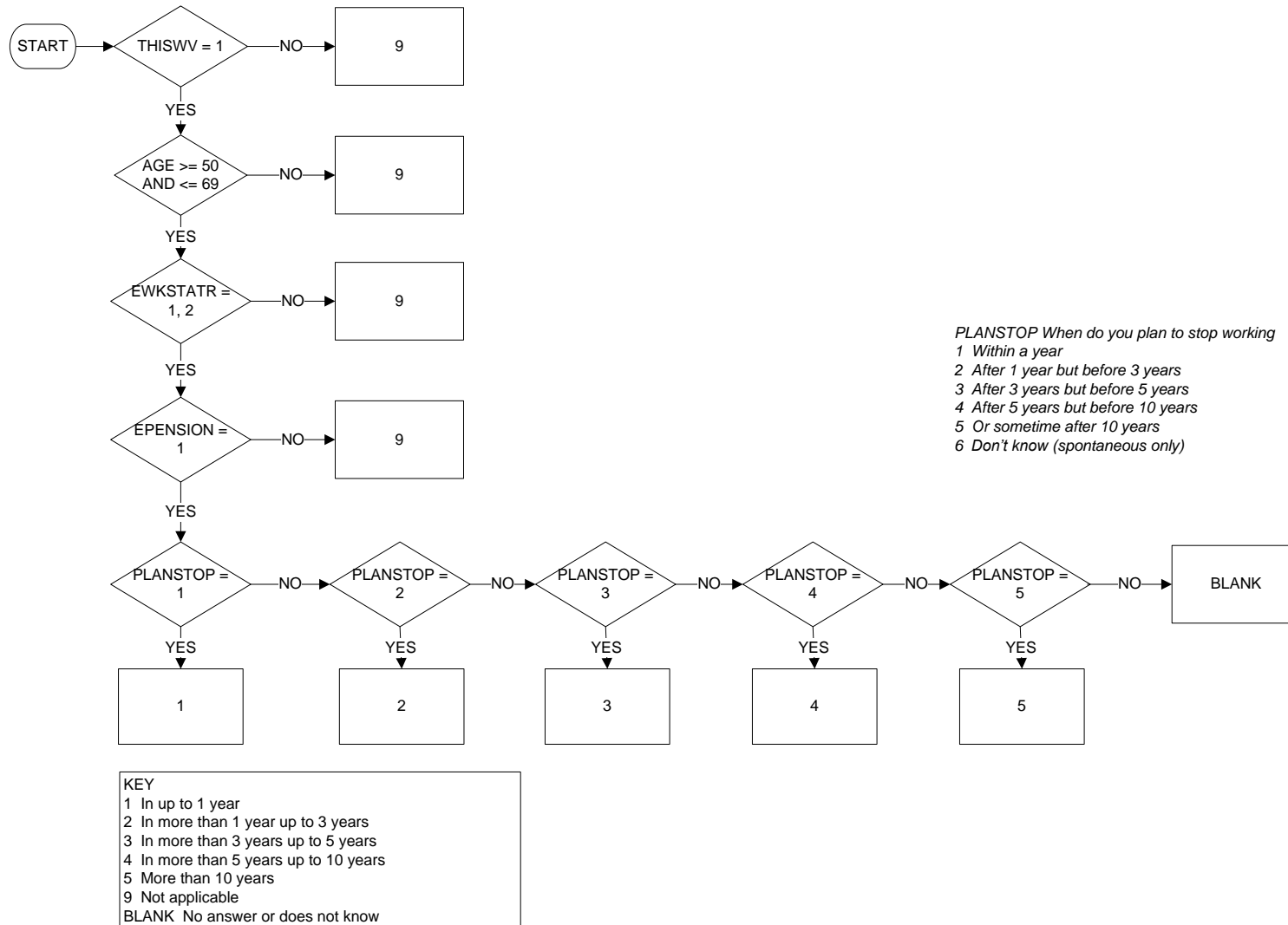

EBUILDPEN1 Pension rights built up so far. Old-age pension. Statutory scheme (Eurostat AHM 2012 Col 214)

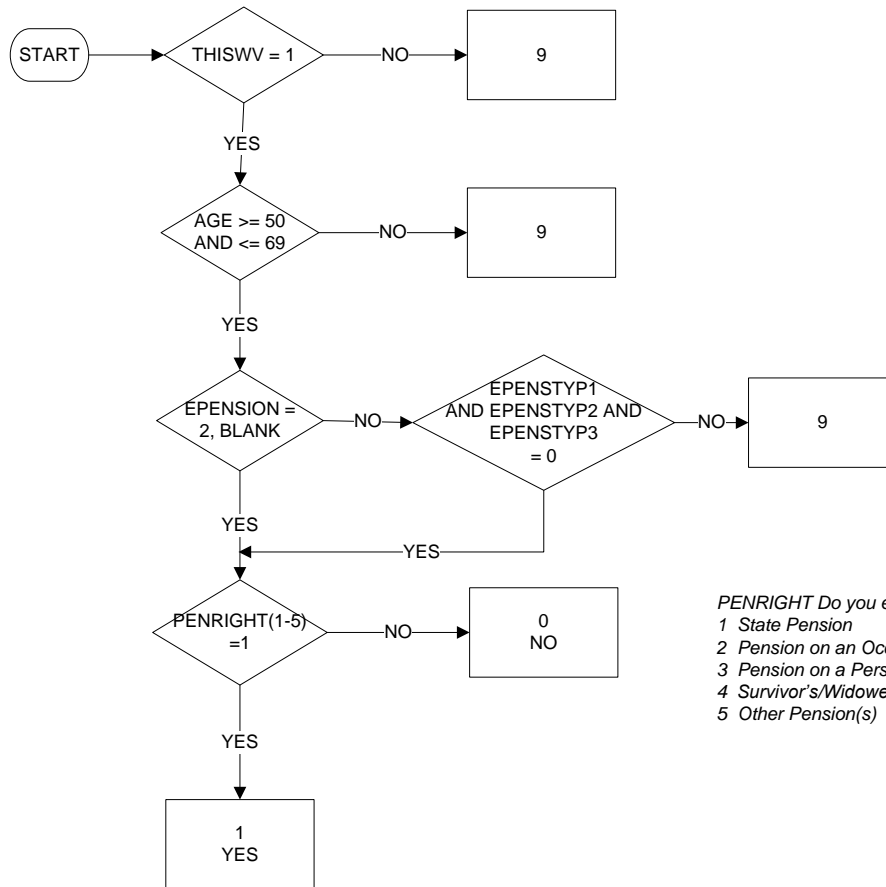

*PENRIGHT* Do you expect to receive any of the following types of pension  
 1 State Pension  
 2 Pension on an Occupational Scheme  
 3 Pension on a Personal Scheme  
 4 Survivor's/Widower's Pension  
 5 Other Pension(s)

EBUILDPEN2 Pension rights built up so far. Old-age pension. Occupational scheme (Eurostat AHM 2012 Col 215)

Start date: Jan 2012  
End date: Dec 2012

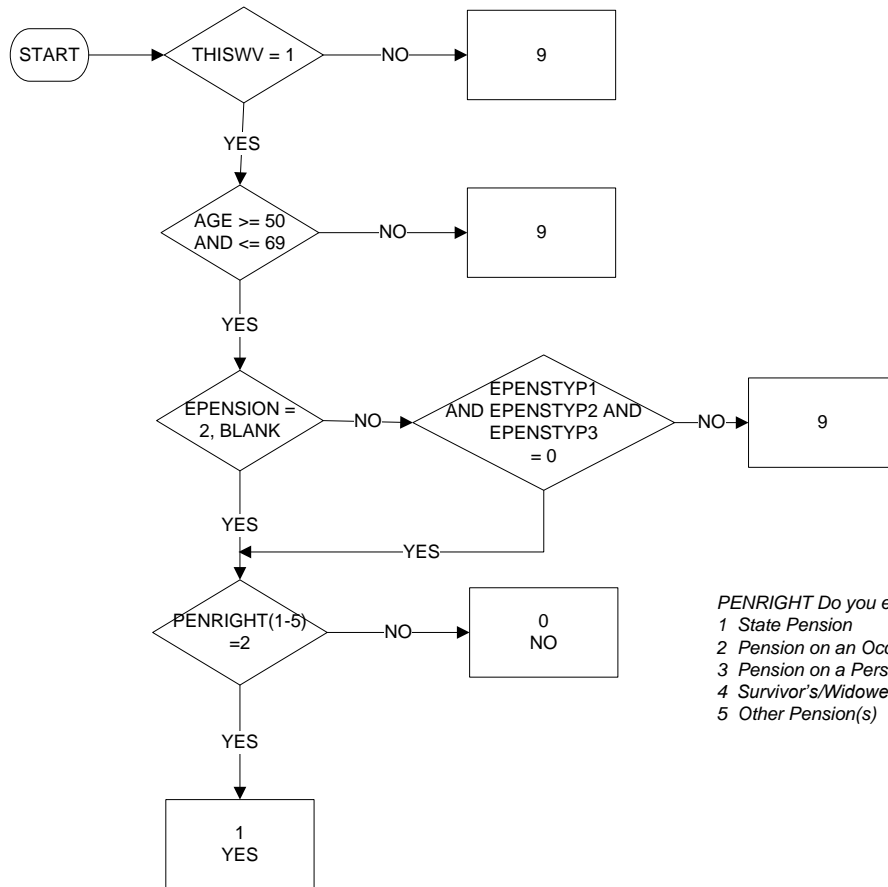

*PENRIGHT* Do you expect to receive any of the following types of pension  
 1 State Pension  
 2 Pension on an Occupational Scheme  
 3 Pension on a Personal Scheme  
 4 Survivor's/Widower's Pension  
 5 Other Pension(s)

EBUILDPEN3 Pension rights built up so far. Old-age pension. Personal scheme (Eurostat AHM 2012 Col 216)

Start date: Jan 2012  
End date: Dec 2012

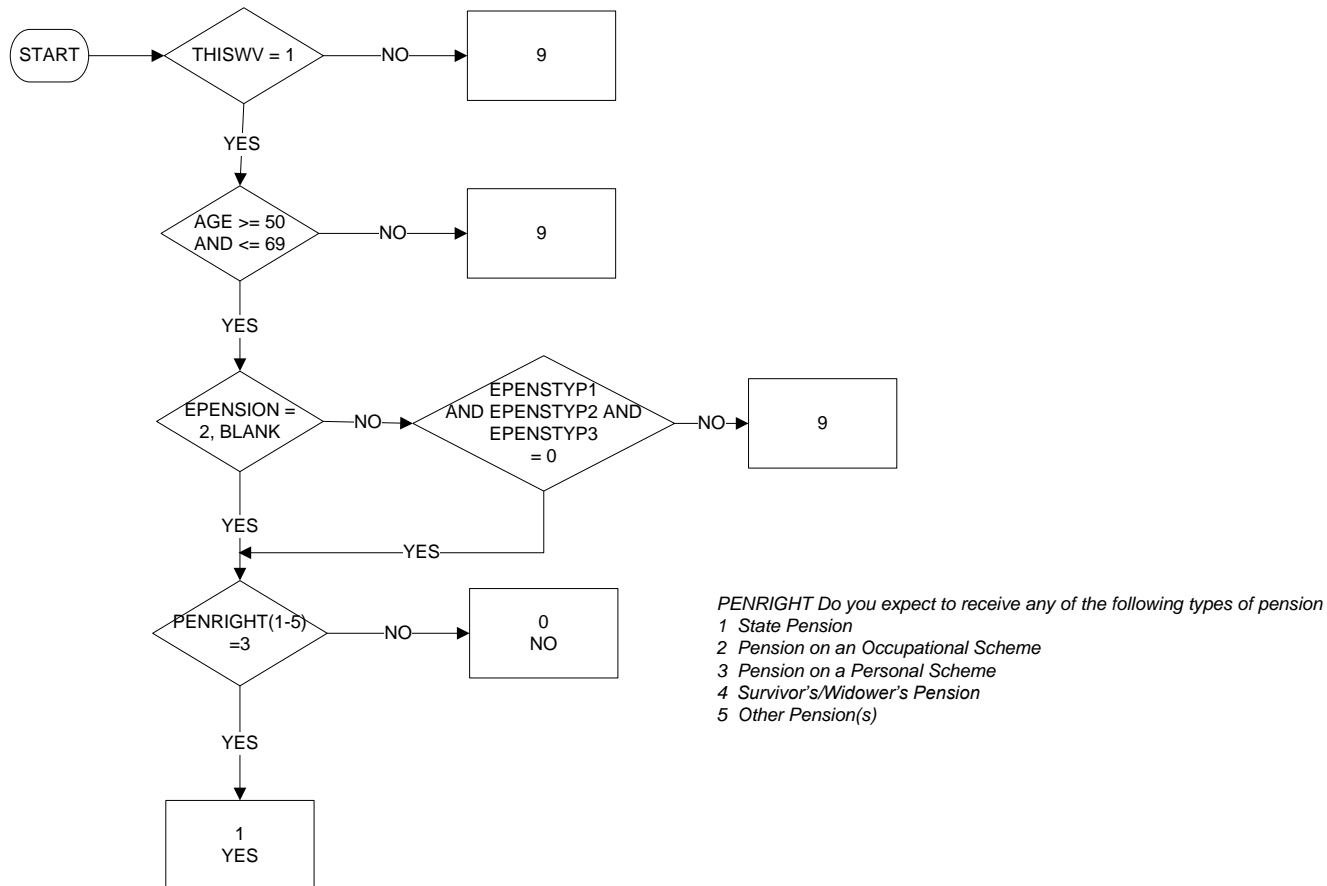

EBUILDPEN4 Pension rights built up so far. Old-age pension. Scheme unknown (Eurostat AHM 2012 Col 217)

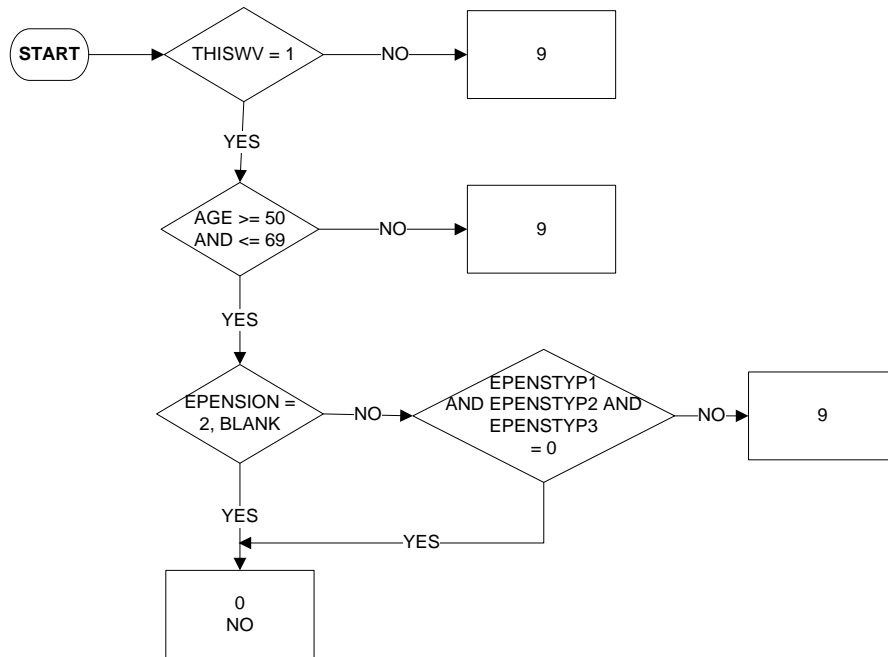

*Note*  
*'Old age pension. Scheme unknown' not available in UK LFS so all applicable cases set to 'No'*

ECONWORK Expects to continue working/looking for a job after receiving old-age pension  
(Eurostat AHM 2012 Col 218)

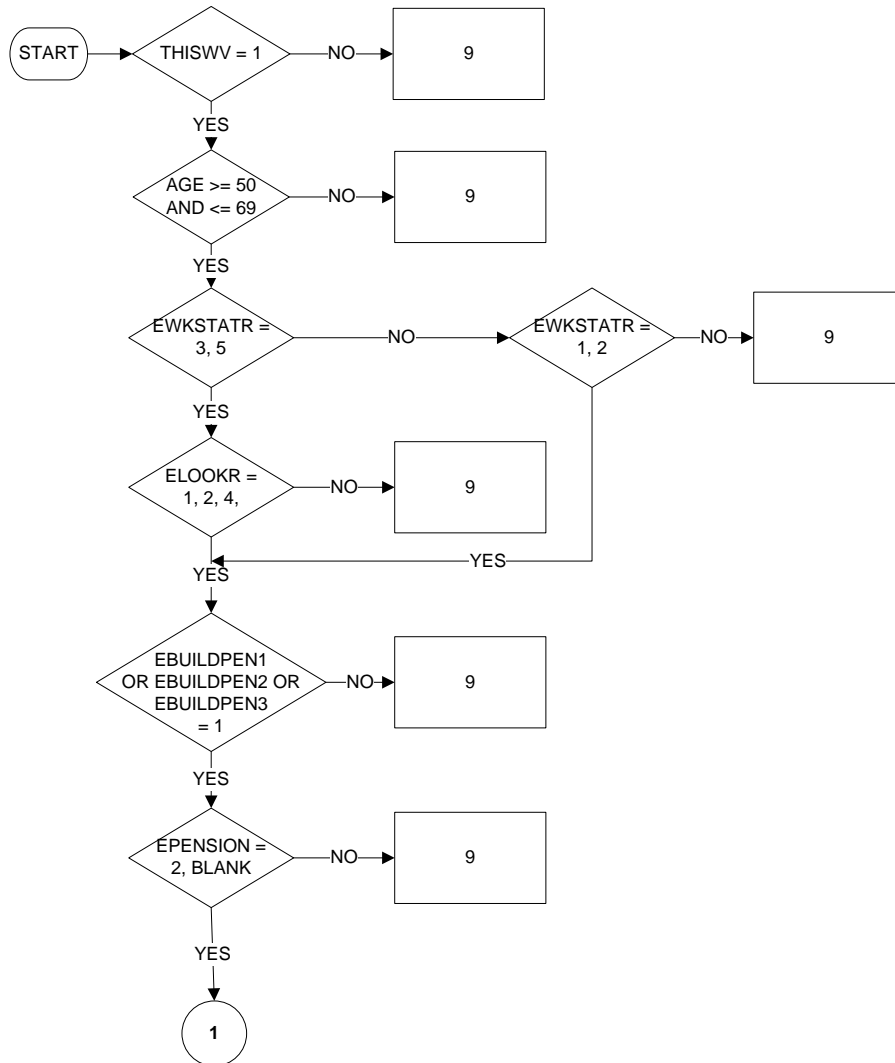



ECONWORK Expects to continue working/looking for a job after receiving old-age pension  
(Eurostat AHM 2012 Col 218)

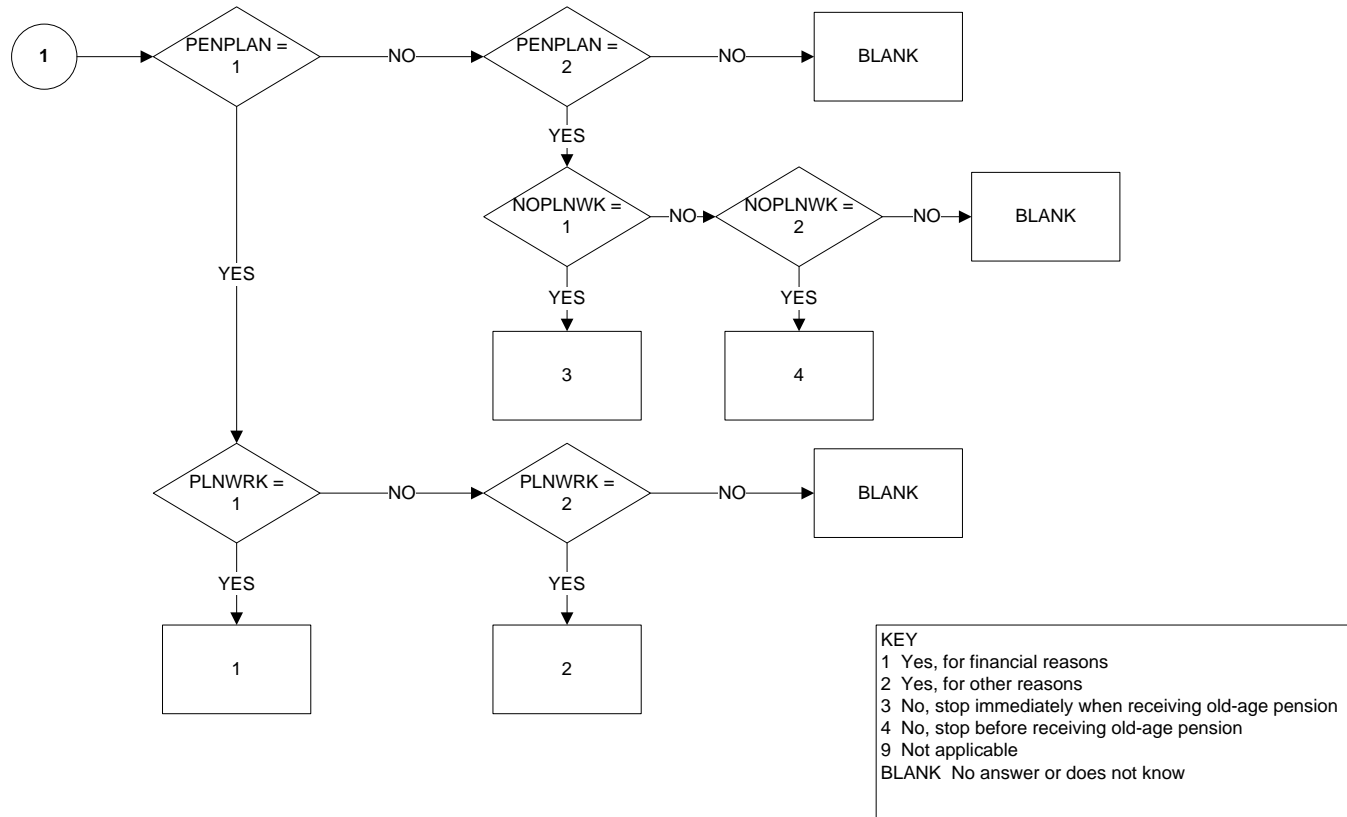

## 1. Policy background and focus of the 2012 Labour Force Survey module on transition from work to retirement

Set up at the Lisbon European Council of March 2000, the Open Method of Coordination provides a framework of political coordination without legal constraints. Member States agree to identify and promote their most effective policies in the fields of Social Protection and Social Inclusion with the aim of learning from each other's experiences. Based on commonly agreed objectives and indicators Member States submit national strategies for common evaluation in the area of adequate and sustainable pension provision, also in the light of population ageing.

An improvement of the understanding of the paths of transition out from the labour market to retirement is not only relevant in the framework of the Open Method of Coordination in the field of pensions but also within the Europe 2020 Strategy<sup>1</sup>. In particular, guideline 7 refers to increasing labour market participation and reducing structural unemployment and demands to "...increase labour force participation through policies to promote active ageing" and "to bring by 2020 to 75% the employment rate for women and men aged 20-64 including through the greater participation of (...) older workers".

In 2006, a LFS ad hoc module on transition from work to retirement was conducted for the first time. It aimed in particular at establishing firstly how the transition at the end of the career towards full retirement takes place or is expected to take place, and secondly at analysing the factors determining the exit from work and the factors that could make people postpone the exit from work.

The results from the module have contributed to the analyses in the 2008 Joint Report on Social Protection and Social Inclusion and have also formed the basis of the special report, *Promoting longer working lives through pension reforms - Early Exits from the labour market*, adopted by the Social Protection Committee in January 2008<sup>2</sup>. The LFS ad hoc module of 2006 formed a key foundation of the report and helped to identify new areas of policy as pertaining to extending working lives in order to ensure adequate and sustainable pensions in the future. The findings of the report based on the data showed that pension reforms focused on extending working lives by strengthening the link between contributions and benefits, increasing eligibility criteria, raising the retirement age, or giving actuarial financial incentives to work longer and disincentives for earlier retirement.

The Joint Report adopted by the Council in February 2008 observed that employment rates have risen for all categories of older workers due to active inclusion measures; pension and labour market reforms have improved incentives to work, but still more people need to work more and longer.

The 2009 Joint Report reiterated that the long-term adequacy and sustainability of pension systems depend on continued efforts to reach the Lisbon target of a 50% employment rate of older workers. Furthermore, reference was made to the effects of the economic downturn on the age management and postponement of retirement indicating the importance to monitor the labour market situation of older workers and the durability of the policies in place to sustain the employment of older workers.

The 2010 Joint Report observed that the balance between adequacy and sustainability - the object of a decade of pension reforms - is under further pressure from the financial and economic crisis. Increased employment rates for older workers must now be defended against rising unemployment.

The LFS module for 2012 is, therefore, crucial for following up these reforms and for forming a basis for further policy making in this field.

The 2012 LFS ad hoc module "Transition from work to retirement" aims at answering four main questions:

- how people leave the labour market
- why they left the labour market
- why they did not stay longer and
- how long the active population, aged 50 to 69, expects to be in the labour market

Information on the past is preferable to forward-looking information because the former is based on facts; however the module should include some forward-looking elements as well to get a full picture.

The results are intended for use in the framework of the Open Method of Coordination in the field of pensions, for the Joint Social Protection, Social Inclusion report, and in the framework of the Europe 2020 Strategy, in particular for the monitoring of the guideline on increasing labour market participation and promoting active aging.

## 2. Target population

The target population is everybody aged 50 to 69, currently working or having worked after the age of 50.

In order to decide the questions to be asked and to facilitate the implementation of the module in paper questionnaires, the target population will be classified according to a *simplified ILO status* in three main subgroups: *Employed*, *Unemployed* and *Inactive*. The simplification only affects the distinction between the unemployed and the inactive.

The definition is based on two core variables: WSTATOR and SEEKWORK:

- EMPLOYED: WSTATOR = 1, 2
- UNEMPLOYED: WSTATOR=3, 5 AND SEEKWORK =1, 2, 4
- INACTIVE: WSTATOR=3, 5 AND SEEKWORK =3

WSTATOR=4, 9 are not considered in the filters of the module because the first value (WSTATOR=4) refers to people doing the compulsory military service and the second one (WSTATOR=9) to children less than 15 years old. A similar argument is valid for SEEKWORK=9 (SEEKWORK=9 refers to people aged 75 or older and to interviewees having answered WSTATOR=1, 2, 9 and SIGNISAL ≠ 3).

Respondents with SEEKWORK=2 (has found a job beginning in more than 3 months) are considered as unemployed (whereas they are inactive in the LFS) because the kind of questions addressed to the unemployed in this module are more suitable for them than the ones for the inactive.

The module is mainly focused on the population receiving a pension. To know of whom this population is made up of, the module starts by asking a general question on reception of a pension. Depending on the answer and on the simplified ILO status, the respondents are routed through the module (see scheme at the end of the document).

## 3. Definition of pension

The legal frameworks and the pensions systems vary significantly between countries. This situation makes it difficult to give a common definition that is valid for all countries and easy to implement in a household survey. For that reason, a two-step approach has been taken.

In order not to start the module with a too difficult question on pensions, which might lead to a wrong routing from the very beginning, the first variable of the module should be broad and simple, in the sense that no strict definition of pension will be provided to the respondent. This will help the start of the module as not everybody is able to identify precisely what type of pension or benefit he/she receives.

In this first step the respondent will decide, basically via his/her own judgment, whether the type of benefit he or she is receiving is a pension. Only one general condition is required: the payment considered as pension has to be a **regular and periodic benefit in cash -apart from salaries or wages-** and including bank transfers, cheques and similar payments. Lump-sum payments and benefits in kind are excluded from the definition.

The target definition includes pensions which are of any of the types below:

- public or private

- voluntary or mandatory
- defined contribution or defined benefit

Means-tested pensions, pensions to support the income of elderly persons and disability pensions should all be covered.

In a second step (i.e. after the introductory question), the type of pension received will be investigated. In this case, the four functions indicated in the ESSPROS<sup>3</sup> module on pension beneficiaries (old-age, disability, survivor's and unemployment functions) will be used as the general framework<sup>4</sup>. This framework will be supplemented to get more detailed and specific information on the old-age pensions (i.e. statutory, occupational and personal schemes).

**i) Old-age pensions** are periodic payments intended to maintain the income of the beneficiary after retirement from gainful employment at the legal or standard age or to support the income of elderly persons. For the purpose of the module, the **anticipated old age pension** (periodic payments intended to maintain the income of the beneficiary who retires before the legal or standard age, with or without reduction of the normal pension) and the **partial retirement pension** (periodic payments of a portion of the full retirement pension to older workers who continue to work but reduce their working hours or whose income from a professional activity is below a set ceiling; this partial pension is usually converted into an old age pension when the beneficiary retires completely) are considered old-age pensions.

The old-age pensions will be further classified into three categories<sup>5</sup>:

- **Statutory old-age pensions** cover social security pensions and similar statutory programmes administered by the general government; that is central, state, and local governments, as well as other public sector bodies such as social security institutions. The unfunded pay-as-you-go (PAYG) and the minimum pension schemes are the main categories included in this group. All Member States have an unfunded PAYG pension system to which people in employment contribute (which can also include a reserve fund). In some Member States, it is complemented by statutory funded schemes.
- **Occupational pensions** are private pensions linked to an employment or professional relationship between the worker and the entity that establishes the pension plan (the plan sponsor). Occupational plans may be established by employers or groups thereof (e.g. industry associations) and labour or professional associations, jointly or separately. The plan may be administered directly by the plan sponsor or by an independent entity (a pension fund or a financial institution acting as pension provider). In the latter case, the plan sponsor may still have oversight responsibilities over the operation of the plan. Both mandatory and voluntary occupational plans are included. The occupational pension schemes can be mandatory for the employer (sectoral or cross-sectoral) or resulting from collective agreements (with membership either mandatory or not).
- **Personal pensions** are private pensions which do not have to be linked to an employment relationship. The pension plans are established and administered directly by a pension fund or a financial institution acting as pension provider without any intervention of employers. Individuals independently purchase and select material aspects of the arrangements. The employer may nonetheless make contributions to personal pension plans. Some personal plans may have restricted membership. Both mandatory and voluntary personal plans are included. Individual contracts with pension funds, life insurance companies or pension savings institutions that deliver annuities are included; this type of individual provision is generally available throughout the EU, in particular in Germany (Riester pensions) and France (PERP). Long term savings not specifically for pension purpose are not included.

**ii) Disability pensions** are periodic payments intended to maintain or support the income of someone below the legal or standard retirement age who suffers from a disability which impairs his or her ability to work or earn beyond a minimum level. **Early retirement benefits in case of reduced ability**

**to work** (periodic payments to older workers who retire before reaching the legal or standard retirement age as a result of reduced ability to work) are also in this category.

**iii) Survivor's pensions** are periodic payments to people whose entitlement derives from their relationship with the deceased person protected by the scheme (widows, widowers, orphans and similar).

**iv) Early retirement benefits for labour market reasons (unemployment pension)** are periodic payments to older workers who retire before reaching the legal or standard retirement age due to unemployment or to job reduction caused by economic measures such as restructuring of an industrial sector or of a business. These payments normally cease when the beneficiary becomes entitled to an old age pension. **These benefits only exists in some Member States and the number of persons concerned are quite limited** (on this respect see above second footnote on ESPROSS).

The **legal retirement age** for old age benefits means the age at which old age benefits become payable, if laid down in legislation or by contract. This age can vary both between and within countries, depending on the sector of activity, occupation, gender and so on.

When no legal retirement age exists, a **standard retirement age** is to be used, which means the retirement age offered by the scheme that paid the pension to the beneficiary.

**Benefits which are not considered as a pensions** are:

- Full and partial unemployment benefits
- All medical care and care allowances specific to disability or old-age
- Benefits provided to replace in whole or in part earnings during temporary incapacity to work due to sickness or injury
- Family allowances
- Long term savings and life insurance contracts not specifically for pension purpose.

**Full unemployment benefits** are benefits compensating for loss of earnings where the person is capable of working and available for work but is unable to find a suitable employment, including persons who had not previously been employed.

**Partial unemployment benefits** are benefits compensating for loss of wage or salary due to formal short time working arrangements or intermittent work schedules, irrespective of their cause (business recession, slow-down, breakdown of equipment, climatic conditions, accidents, ...) and where the employer/employee relationship continues.

**Care allowances** are benefits paid to disabled or to old people who need frequent or constant assistance to help them the extra costs of attendance.

Benefits provided to replace in whole or in part earnings during **temporary incapacity to work due to sickness or injury** include, in particular, the paid sick leave. The **paid sick leave** are flat-rate or earnings-related payments intended to compensate the protected person in full or in part for the loss of earnings caused by temporary inability to work due to sickness or injury. These benefits may be paid by autonomous social protection schemes, but they may also be provided by the employer in the form of continued payment of wages and salaries during the period of sickness.

The **family allowances** include benefits that:

- provide financial support to households for bringing up children;
- provide financial assistance to people who support relatives other than children;
- provide social services specifically designed to assist and protect the family, particularly children.

The most common types of benefits under this heading are the income maintenance in the event of childbirth, the birth grant, the parental leave benefits, benefits to meet specific needs of lone parent families or families with handicapped children.

### **General implementation recommendation**

Countries are asked to find the best way to implement the module, and against the different national backgrounds they are encouraged to develop best practices to implement the variables of the ad hoc module in the national context.

Some codes might be irrelevant at national level, or the coding of some variables can (partly) be derived from other answers or already existing national questions - in such cases, countries should adapt the ad hoc module questions accordingly not to confuse or annoy respondents.

For national purposes countries might also add additional categories in order to get more information than needed at European level.

**General filter and list of variables****GENERAL FILTER**

Everybody aged 50-69 working or having worked after the age of 50.

**PENSION Col 197****Description**

Person receives or does not receive a pension.

**Filter**

Everybody aged 50 to 69, working (WSTATOR=1, 2) or having worked after the age of 50 (WSTATOR=3, 5 and (YEARPR-YEARBIR)>49)).

<b>PENSION</b>	<b>Person receives a pension</b>	Everybody aged 50-69 and (WSTATOR=1, 2 or (WSTATOR=3, 5 and (YEARPR-YEARBIR)>49))
1	Yes	
2	No	
9	Not applicable (not included in the filter)	
Blank	No answer or does not know	

**Purpose**

To classify the target population in two groups, one composed of those currently receiving a pension and the other of those not receiving one.

**Definition**

The respondent will decide by own assessment whether the type of benefit he or she is currently receiving is a pension. Apart from the self-assessment, the only restrictions to be fulfilled are that the payments should be regular, periodic and in cash -apart from salary or wages- including bank transfers, cheques and similar payments, and excluding benefits in kind (e. g. accommodation, assistance in carrying out daily tasks, rehabilitation, home help, reduction in prices, tariffs and fares for old-aged persons).

Public, private, compulsory, voluntary, defined contribution, defined benefit, means-tested and minimum pensions are included.

A pension received in the past as a single one-shot payment is not a pension currently received.

**Implementation rule**

This variable is closely linked to the next one (PENSTYPE). If the respondent asks for a clarification on the concept of pension, reference should be made to the national pension system and to the definitions applied in PENSTYPE.

Persons not able to answer or asking for clarification should be confronted with the list of the different pensions and benefits available at national level (see the implementation rule section in the next variable, PENSTYPE). If this leads to information indicating that 1 or 2 should be coded, PENSION should be filled in accordingly and the survey will continue. Otherwise,

PENSION is left blank and the respondent will answer the same questions as if he/she was not receiving any pension (PENSION=2).

Persons answering "No" (PENSION=2) should be controlled with an additional question. The respondents should specify whether they are receiving any regular benefit in cash (including bank transfers, cheques and similar payments, and excluding benefits in kind). In case this benefit in cash turns out to be a pension, the answer will be changed to "Yes" (PENSION=1) and variable PENSTYPE should be filled in.

**The NSI should establish a list of the different pensions and benefits available at national level and assign them to the relevant code.** Examples are the national mappings available in CIRCA<sup>6</sup>. The interviewers' manual should include the list, complemented with definitions, examples of the most important pension benefits and similar terms or synonyms. The NSI should also assess whether the national list should be complemented with foreign pensions.

It is recommended that answers to MAINSTAT and to PENSION are compared. If an answer other than 1 ("Yes") is given to PENSION and the person is likely to be receiving a pension (MAINSTAT=4, in retirement or early retirement) the interviewer should confirm the answers. A similar control could also be based on the answer to LEAVREAS (06, early retirement or 07, normal retirement).

## PENSTYPE Col 198/205

### Description

Type of pension(s) the person is currently receiving.

### Filter

Everybody receiving a pension (PENSION=1).

PENSTYPE		Type of pension(s)	PENSION=1
PENSTYP1	1: Yes; 0: No	Old-age pension. Statutory scheme.	
PENSTYP2	1: Yes; 0: No	Old-age pension. Occupational scheme	
PENSTYP3	1: Yes; 0: No	Old-age pension. Personal scheme	
PENSTYP4	1: Yes; 0: No	Old-age pension. Scheme unknown	
PENSTYP5	1: Yes; 0: No	Unemployment pension	
PENSTYP6	1: Yes; 0: No	Disability pension	
PENSTYP7	1: Yes; 0: No	Survivor's pension	
PENSTYP8	1: Yes; 0: No	Other pension(s) or type of pension unknown	
	99999999	Not applicable (not included in the filter)	

**Purpose:** To know, for those having answered yes in the previous question, which type of pension(s) he or she is receiving.

### Definition

See details of the definition of pensions in section 3 above.

NOTE: this is an eight-digit variable, where the first digit refers to PENSTYP1, the second to PENSTYP2 etc.



### Implementation rule

A person can receive several pensions of a given category, for instance two different “statutory old age pensions” if (s)he has worked successively in the private sector and as a civil servant, or two or more occupational pensions if (s)he has worked in two different firms. The module will not be able to differentiate those cases from the ones receiving only one pension of a given category.

The concepts covered by this variable should be “translated” to the most common terms used in each country. **As stated in PENSION, the NSI should establish a list of the different pensions and benefits available at national level and assign them to the relevant code.** The national mappings currently available can be found in CIRCA<sup>7</sup>. The interviewers' manual should include the list, complemented with definitions, examples of the most important pension benefits and similar terms or synonyms. The NSI should also assess whether the national list should be complemented with foreign pensions.

If the type of pension has changed in the past, e.g. a disability pension has been converted into an old-age pension, the current type (i.e. old-age pension) should be coded.

Before asking the question on the type of pension(s) the person is currently receiving (PENSTYPE), it is advisable to inform the respondents on the existence of several types of pensions. The questions could be preceded by the **following text**: “I shall now read a few types of pension to you. Please tell me in each case whether or not you are receiving any of these benefits”.

Respondents should indicate for each of the six basic categories (PENSTYP1-PENSTYP3 and PENSTYP5 to PENSTYP7) whether they are receiving or not a pension of the type included in the category. Categories PENSTYP4 and PENSTYP8 are **residual** categories which should be used only when the respondent knows that the pension is an old-age pension but he/she does not know the type of old-age scheme (PENSTYP4), or the respondent knows that he/she receives a pension, but can not classify it at all (PENSTYP8). Ideally none should have code 1 in PENSTYP4.

Means-tested and minimum pensions and payments to support the income of the interviewee should be coded in the same way as the 'basic' pension the respondent receives.

As this variable is to be seen as multiple choice variable, a code blank for "No answer or does not know" is not foreseen for the individual pension types. The answers of respondents should be coded "Yes" in case of a positive answer and "No" otherwise.

**NOTE 1:** PENSION and PENSTYPE are strongly linked. Against the national background countries should decide whether they consider it easier for respondents to start the module with PENSTYPE and fill PENSION accordingly, given the answers to PENSTYPE.

**NOTE 2:** Unemployment pensions are available in few countries only. For those countries where unemployment pensions are not a relevant option, PENSTYP5 should not be included in the national questionnaire.

**EARLYRET Col 206****Short description**

Incidence of early retirement.

**Filter**

Everybody receiving old-age pension (PENSTYP1=1 or PENSTYP2=1 or PENSTYP3=1 or PENSTYP4=1).

<b>EARLYRET</b>	<b>Early retirement</b>	<b>PENSTYP1=1 or PENSTYP2=1 or PENSTYP3=1 or PENSTYP4=1</b>
1	Yes	
2	No	
9	Not applicable (not included in the filter)	
Blank	No answer or does not know	

**Purpose:** This variable aims at knowing whether old-age pensioners retired via an early retirement path.

**Definition**

EARLYRET should give the size of the population which profited from early retirement measures. Early retirement as understood here covers in principle all measures which are covered under "early retirement" by the policy side. To be concrete, early retirement includes:

- **Anticipated old age pensions:** periodic payments intended to maintain the income of beneficiaries who retire before the legal/standard age as established in the relevant scheme. This may occur with or without a reduction of the normal pension.
- **Disability pensions:** periodic payments intended to maintain or support the income of someone below the legal/standard retirement age as established in the reference scheme who suffers from a disability which impairs his or her ability to work or earn beyond a minimum level laid down by legislation.
- **Early retirement pensions in case of reduced ability to work:** periodic payments to older workers who retire before reaching the legal/standard retirement age as established in the reference scheme as a result of reduced ability to work. These payments normally cease when the beneficiary becomes entitled to an old age pension.
- **Early retirement pensions for labour market reasons:** periodic payments to older workers who retire before reaching the legal/standard retirement age due to unemployment or to job reduction caused by economic measures such as the restructuring of an industrial sector or of a business. These payments normally cease when the beneficiary becomes entitled to an old age pension.
- **Early retirement pensions due to seniority (long career or long contribution period):** periodic payments to older workers who retire before reaching the legal/standard retirement age as established in the reference scheme, due to complete length of contribution or insurance period.
- **Early pensions due to family reasons:** periodic payments to workers who retire before reaching the legal/standard retirement age as established in the reference scheme as compensation for parenthood or for family care duties.

But for instance also the parts of the following measures which are/were **explicitly defined as early retirement measures** in a move to full retirement in a given country:

- **Full unemployment benefits:** benefits compensating for loss of earnings where a person is capable of working and available for work but is unable to find suitable employment, including persons who had not previously been employed.
- **Partial retirement pension:** periodic payment of a portion of the full retirement pension to older workers **who continue to work** but reduce their working hours or whose income from a professional activity is below a set ceiling. The partial pension is converted into a full pension (old age pension) when the beneficiary retires completely.

### Implementation rule

Early retirement has to be seen in relation to the standard situation for a given sex, occupational group etc. Persons with previous professions with low retirement ages, e.g. army, policemen, miners, must not systematically be coded "Yes", but only if they were affected by further early retirement measures going beyond the normal rules for their profession.

Workers in hazardous or arduous working conditions who retire before reaching the legal/standard retirement age as established in the reference scheme due to health problems should answer code 1.

The NSI should establish a list of the different early retirement measures. The interviewers' manual should include the list, complemented with definitions, examples, usual terms and synonyms.

## AGEPENS Col 207/208

### Short description

Age at which a person first received an old-age pension.

### Filter

Everybody receiving an old-age pension (PENSTYP1=1 or PENSTYP2=1 or PENSTYP3=1 or PENSTYP4=1)

AGEPENS	Age at which person first received an old-age pension	PENSTYP1=1 or PENSTYP2=1 or PENSTYP3=1 or PENSTYP4=1
99 Blank	2 digits Not applicable (not included in the filter) No answer or does not know	

**Purpose:** This variable aims at knowing at which age the person started to receive the first old-age pension.

### Definition

Age at which the person started to receive the first old-age pension.

### Implementation rule

If the person is receiving two or more old-age pensions, the age at which the person started receiving the first one should be coded.

Countries might prefer to ask for the year the first old-age pension was received. For the transmission to Eurostat, this should however be recoded into AGEPENS.5.

## REASNOT Col 209

### Short description

Main reason for not staying longer at work at the moment of leaving the labour market/last job.

### Filter

Every inactive (simplified ILO status: WSTATOR=3, 5 and SEEKWORK=3) receiving a pension (PENSION=1).

REASNOT	Main reason for not staying longer at work	WSTATOR=3, 5 and SEEKWORK=3 and PENSION=1
1	Favourable financial arrangements to leave	
2	Lost job and/or could not find a job	
3	Had reached the maximum retirement age	
4	Had reached eligibility for a pension	
5	Other job-related reasons	
6	Own health or disability	
7	Family or care-related reasons	
8	Other	
9	Not applicable (not included in the filter)	
Blank	No answer or does not know	

**Purpose:** This variable aims at identifying the main factor that has caused the person to leave the labour market.

### Definition

The variable addresses the situation at the moment of leaving the labour market/last job.

- Code 1: Favourable financial arrangements to leave: this code includes all cases where financial considerations led the respondent to stop working / go to retirement, as well as cases where the decision was based on the fear that if retirement was postponed it would result in a lower pension due to pension reforms. The code covers in particular bonuses from employers and golden handshakes.
- Code 2: Person lost the previous job and/or did not find a new job.
- Code 3: This code applies only in case the person had reached the maximum legal/standard retirement age. The **maximum legal retirement age** means the age at which the employee is forced by law to leave his current job. When no legal retirement age exists, a **maximum standard retirement age** is to be used which means the age at which the retirement has to take place according to a contract or other agreement. This can for instance be defined by collective agreements between trade unions and employers. In either case, the relevant age can vary both between countries and within Member States, depending on the sector of activity, occupation, gender and so on.
- Code 4: Had reached eligibility for a pension covers answers like: "I retired because I reached the age at which I could start receiving the pension".

- Code 5: Other job-related reasons not included above like inconvenient working hours, tasks, health and safety at the job place, job stress, job too demanding, and skills not adequate or not valued, employer's attitude.
- Code 6: Person retired because of own health problems or disability.
- Code 7: Family or care related reasons like care responsibilities (person had to care for children or dependant persons); passing away of a close relative; business handover ...
- Code 8: Other reasons: it is a residual code which should be used only when none of the previous codes fits.

### Implementation rule

If it is not possible for the respondent to choose a “main reason”, the first code that applies in the order of the list should be used. The first codes refer rather to “job-related reasons” and the following codes rather to “personal or family” reasons.

Early retirement is not per se a reason for not staying longer at work. If somebody provides such answer the interviewer should request why the person retired before the legal/standard retirement age: good financial arrangements (code=1), had reached eligibility for a pension (code=4), "forced" by employer (code=5), own health problems (code=6) ...

Especially in case of computer-assisted interviews (CAPI, CATI) it is recommended that answers to LEAVREAS and to REASNOT are compared to check for possible inconsistencies.

## WORKLONG Col 210

### Short description

Wish to stay longer at work (be it in the last or any other job) at the moment of leaving the labour market/last job.

### Filter

Every inactive (simplified ILO status: WSTATOR=3, 5 and SEEKWORK=3) receiving a pension (PENSION=1).

WORKLONG	Wish to stay longer at work	WSTATOR=3, 5 and SEEKWORK=3 and PENSION=1
1	Yes	
2	No	
9	Not applicable (not included in the filter)	
Blank	No answer or does not know	

**Purpose:** This variable aims at establishing whether the person would have preferred to stay longer at work.

### Definition

The question should be answered based on the wish of the respondent at the moment of leaving the work.

**Implementation rule**

For respondents who say that it was not possible for them to stay longer at work (due to legal restrictions or employer's decisions), it should be explained that the question refers to their preference in case the circumstances which prevented them from working longer had not been given.

Persons answering something such as "I would have liked to continue working but only if I had had a possibility to change to another workplace (or to another job at the latest workplace)" should be coded "Yes". The previous variable (REASNOT) gives the reason for not staying longer.

**REDUCHRS Col 211****Short description**

Person reduced working hours in a move towards full retirement.

**Filter**

Employed (ILO status: WSTATOR=1, 2) aged 55-69 or

Inactive (simplified ILO status: WSTATOR=3, 5 and SEEKWORK=3) receiving a pension (PENSION=1).

<b>REDUCHRS</b>	<b>Person reduced working hours in a move towards full retirement</b>	(WSTATOR=1, 2 and aged 55-69) or (WSTATOR=3, 5 and SEEKWORK=3 and PENSION=1)
1	Yes, before receiving the first old-age pension	
2	Yes, since or after receiving the first old-age pension	
3	No	
9	Not applicable (not included in the filter)	
Blank	No answer or does not know	

**Purpose:** This variable aims at knowing whether the person, voluntary or involuntary, reduced working hours in a move towards full retirement and, in case of receiving old age pension, when this happened.

**Definition**

For the inactive the reference period is in the past, before leaving the last job. For the employed the reference period is the present.

**Implementation rule**

This variable is addressed to all employed aged 55-69, irrespective of their answer to the variable PENSION, and to the inactive receiving a pension (PENSION=1).

For people not receiving an old-age pension, code 2 is not valid and the meaning of code 1 is simply "Yes".

"Yes" should be the answer when a reduction of working hours happened, **no matter whether it was within an official progressive scheme or just a private agreement between the employee and the employer**. The same applies when the worker reduced the number of extra hours (overtime), even if there was no private agreement between the employee and the employer.

A person working full time who changed to part-time work should be coded "Yes" if the reason for the change was a move towards retirement.

A person working part-time should be coded "No" if the number of hours was not further reduced in a move towards retirement.

The appropriate code for a person who leaves a job when reached eligibility for a pension and started a new part-time job is 2.

Self-employed who reduced their working hours in a move towards retirement should be coded "Yes".

In case a person reduced the working hours before receiving the first old-age pension and again since or after receiving it, code 1 "Yes, before receiving the first old-age pension" should be coded provided that the reason for the first reduction was the move towards full retirement.

"No" also covers answers like "It is not possible for me to reduce the number of hours".

An employed person who has asked for a reduction of the working time but who has not yet reduced their hours should answer "No".

Employees forced to reduce the working hours to continue at work should be coded 3 ("No") when the reduction is not a move towards full retirement.

It is recommended to implement this variable with two questions. The first one would ask whether the person reduced the working hours in a move towards retirement. The second one would require whether the reduction was before or after receiving the first old-age pension; the second question would be asked only if the person receives an old-age pension and answered yes to the previous question.

## STAYWORK Col 212

### Short description

Main reason for staying at work.

### Filter

Employed (ILO status: WSTATOR=1, 2) receiving a pension (PENSION=1)

STAYWORK	Main reason for staying at work	WSTATOR=1, 2 and PENSION=1
1	To establish or increase future retirement pension entitlements	
2	To provide sufficient personal/household income	
3	Combination of 1 and 2	
4	Non-financial reasons, e.g. work satisfaction	
9	Not applicable (not included in the filter)	
Blank	No answer or does not know	

**Purpose:** This variable aims at identifying the main factor that makes the person stay at work.

### Definition

Code 3 should be used when the respondent gives the same importance to the current income (code 2) and the future income (code 1).

Code 4: Non-financial reasons include for instance work satisfaction ("I like working"), flexible working arrangements, good opportunities to update (labour) skills, healthy and safe workplace, appreciation at work, social contacts. This contains answers like "I do not want to stay at home", "If I did

not work I would not know how to use my time", "My children have already left home", "My partner is still working", "I can't find a successor for my business".

NOTE: code 4 is quite general and covers a variety of reasons which are difficult to split into separate codes as they would likely be answered differently against the national and cultural background.

### Implementation rule

A 'retired' person who occasionally worked during the reference week should refer to the reason for being at work during that particular week.

As this question might affect relatively young persons – for instance those receiving a survivor's pension - who are a long way from thinking about retirement or stopping work, it would be helpful for the interview to introduce the question. The following sentence: “You are receiving a pension and are still working...” could be an example.

## PLANSTOP Col 213

### Short description

Plans to stop work in the future.

### Filter

Employed (ILO status: WSTATOR=1, 2) receiving a pension (PENSION=1)

PLANSTOP	Plans to stop work	WSTATOR=1, 2 and PENSION=1
1	In up to 1 year	
2	In more than 1 year up to 3 years	
3	In more than 3 years up to 5 years	
4	In more than 5 years up to 10 years	
5	More than 10 years	
9	Not applicable (not included in the filter)	
Blank	No answer or does not know	

**Purpose:** It is a forward-looking variable on the planned time span for stopping all work for pay or profit.

### Definition

PLANSTOP asks for the planned time span for stopping all work for pay or profit with the intention of not returning to the labour force.

### Implementation rule

Persons answering something like "I will (have to) work forever" should be coded 5 (More than 10 years)

Responses like "there is no planned age" or "not yet decided" should be coded blank.



**BUILDPEN Col 214/217****Short description**

Pension rights the person has acquired so far.

**Filter**

Everybody aged 50-69, working or having worked after the age of 50, not receiving an old- age pension (PENSION=2, blank or (PENSTYP1 to PENSTYP4=0))

<b>BUILDPEN</b>		<b>Pension rights built up so far</b>	<b>PENSION=2, blank or (PENSTYP1 to PENSTYP4=0)</b>
BUILDPEN1	1: Yes; 0: No	Old-age pension. Statutory scheme.	
BUILDPEN2	1: Yes; 0: No	Old-age pension. Occupational scheme	
BUILDPEN3	1: Yes; 0: No	Old-age pension. Personal scheme	
BUILDPEN4	1: Yes; 0: No	Old-age pension. Scheme unknown	
	9999	Not applicable (not included in the filter)	

**Purpose:** To get information on the pension rights the person has built up so far. The concept to be captured is whether the person is now acquiring pension rights or has acquired some in the past (of one or more of the types indicated in the variable). If so, an affirmative answer should be given even if the respondent has not yet the right to receive the pension.

**Definition**

See details of the definition of pensions in section 3 above.

Answer "Yes" should be coded when the respondent is now contributing to a pension(s) scheme(s), even if the numbers of years, the age or other conditions to receive the pension are not yet fulfilled.

A person who contributed in the past but not now and who will have the right in the future to receive a pension (e.g. because he/she reaches the pensionable age) should also answer "Yes".

Pensions received in the past as a single one-shot payment are not a current pension right, they should be coded as "No".

NOTE: this is a four-digit variable, where the first digit refers to BUILDPEN1, the second to BUILDPEN2, the third to BUILDPEN3 and the fourth to BUILDPEN4.

**Implementation rule**

The vast majority of employees are, in all or nearly all countries, contributing by law to the statutory scheme, therefore an affirmative answer to BUILDPEN1 is expected in such cases.

An affirmative answer in BUILPEN, probably in BUILDPEN3, can be given when a person buys an annuity with a lump-sum payment.

As in PENSTYPE, category BULDPEN4 is a **residual** category which should be used only when the respondent knows that he/she builds up old-age pension rights, but the detailed scheme is unknown. Ideally none should have code 1 in BUILDPEN4.

As this variable is as PENSTYPE to be seen as multiple choice variable, a code blank for "No answer or does not know" is not foreseen for the individual pension types. The answers of

respondents should be coded "Yes" in case of a positive answer and "No" otherwise. Code 0 in BUILPEN1 to BUILPEN4 means "No answer or does not know".

## CONTWORK Col 218

### Short description

Expectations to continue working/looking for a job after receiving old-age pension.

### Filter

Active (simplified ILO status: WSTATOR=1, 2 or (WSTATOR=3, 5 and SEEKWORK=1, 2, 4), building up or having built up old-age pension rights (BUILDPEN≠0000, 9999) not receiving a pension (PENSION=2, blank)

CONTWORK	Expects to continue working/looking for a job after receiving old-age pension	(WSTATOR=1, 2 or (WSTATOR=3, 5 and SEEKWORK=1, 2, 4)) and BUILDPEN≠0000, 9999 and PENSION=2, blank
1	Yes, for financial reasons	
2	Yes, for other reasons	
3	No, stop immediately when receiving old-age pension	
4	No, stop before receiving old-age pension	
9	Not applicable (not included in the filter)	
Blank	No answer or does not know	

**Purpose:** It is a forward-looking variable on whether the respondents building up old-age pension rights expect to continue staying in the labour market, either working or looking for a job, once receiving a pension.

### Definition

CONTWORK asks for the current expectation. In case he/she expects to continue working or looking for a job, the reason (financial or non-financial) is requested.

Code 2, yes for other reasons, is equivalent to code 4 of STAYWORK, covering a large variety of non-financial reasons.

### Implementation rule

Countries should think of best ways to approach the different groups to which this variable is addressed. This might require a split into several questions.

**Specifications of the 2011 ad hoc module on the employment of disabled people**

197/198	HEALTHMA	<i>Type of longstanding health problem or disease (code first main type)</i>	Everybody 15 to 64
	01	Problems with arms or hands (which includes arthritis or rheumatism)	
	02	Problems with legs or feet (which includes arthritis or rheumatism)	
	03	Problems with back or neck (which includes arthritis or rheumatism)	
	04	Cancer	
	05	Skin conditions, including allergic reactions and severe disfigurement	
	06	Heart, blood pressure or circulation problems	
	07	Chest or breathing problems, including asthma and bronchitis	
	08	Stomach, liver, kidney or digestive problems	
	09	Diabetes	
	10	Epilepsy (including fits)	
	11	Severe headache such as migraine	
	12	Learning difficulties (reading, spelling or math disability)	
	13	Chronic anxiety	
	14	Depression	
	15	Other mental, nervous or emotional problem	
	16	Other progressive illnesses (which include multiple sclerosis, HIV,	
	17	Alzheimer's disease, Parkinson's disease)	
	18	Other longstanding health problems	
	99	No longstanding health conditions or diseases	
	Blank	Not applicable (not included in filter)	
199/200	HEALTHSE	No answer or does not know	Everybody 15 to 64 and HEALTHMA = 1 - 17
	01	<i>Type of longstanding health problem or disease (code second main type)</i>	
	02	Problems with arms or hands (which includes arthritis or rheumatism)	
	03	Problems with legs or feet (which includes arthritis or rheumatism)	
	04	Problems with back or neck (which includes arthritis or rheumatism)	
	05	Cancer	
	06	Skin conditions, including allergic reactions and severe disfigurement	
	07	Heart, blood pressure or circulation problems	
	08	Chest or breathing problems, including asthma and bronchitis	
	09	Stomach, liver, kidney or digestive problems	
	10	Diabetes	
	11	Epilepsy (including fits)	
	12	Severe headache such as migraine	
	13	Learning difficulties (reading, spelling or math disability)	
	14	Chronic anxiety	
	15	Depression	
	16	Other mental, nervous or emotional problem	
	17	Other progressive illnesses (which include multiple sclerosis, HIV,	
	18	Alzheimer's disease, Parkinson's disease)	
	99	Other longstanding health problems	
	Blank	No longstanding health conditions or diseases	
		Not applicable (not included in filter)	
		No answer or does not know	

## Specifications of the 2011 ad hoc module on the employment of disabled people, cont'd

Column	Code	Description	Filters/remarks
201/202	DIFFICMA	<i>First basic activity difficulty (code the most important difficulty)</i>	Everybody aged 15 64
	01	Seeing, even if wearing glasses	
	02	Hearing, even if wearing hearing aid	
	03	Walking, climbing steps	
	04	Sitting or standing	
	05	Remembering, concentrating	
	06	Communicating, for example understanding or being understood	
	07	Reaching or stretching	
	08	Lifting and carrying	
	09	Bending	
	10	Holding, gripping or carrying	
	11	None	
	99	Not applicable (not included in filter)	
	Blank	No answer	
203/204	DIFFICSE	<i>Second basic activity difficulty (code the second most important difficulty)</i>	Everybody aged 15 64 And DIFFICMA = 1- 10
	01	Seeing, even if wearing glasses	
	02	Hearing, even if wearing hearing aid	
	03	Walking, climbing steps	
	04	Sitting or standing	
	05	Remembering, concentrating	
	06	Communicating, for example understanding or being understood	
	07	Reaching or stretching	
	08	Lifting and carrying	
	09	Bending	
	10	Holding, gripping or carrying	
	11	None	
	99	Not applicable (not included in filter)	
	Blank	No answer	
205	LIMHOURS	<i>The health condition(s) or disease(s) or difficulty(ies) cause(s) the person's limitation in the number of hours that he/she can work in a week</i>	Everybody aged 15 to 64 and (HEALTHMA = 1-17 or DIFFICMA = 1-10)
	1	Yes, the health condition(s) or disease(s)	
	2	Yes, the activity difficulty(ies)	
	3	Yes, both, the health condition(s)/disease(s) and the activity difficulty(ies)	
	4	No	
	9	Not applicable (not included in filter)	
	Blank	No answer	

## Specifications of the 2011 ad hoc module on the employment of disabled people, cont'd

Column	Code	Description	Filters/remarks
206	LIMTYPEW	<i>The health condition(s) or disease(s) or difficulty(ies) cause(s) the person's limitation in the type of work (for instance, having problems in carrying heavy loads, working outdoors, sitting for a long time) that he/she can do</i>	Everybody aged 15 to 64 and (HEALTHMA = 1-17 or DIFFICMA = 1-10)
	1	Yes, the health condition(s) or disease(s)	
	2	Yes, the activity difficulty(ies)	
	3	Yes, both, the health condition(s)/disease(s) and the activity difficulty(ies)	
	4	No	
	9	Not applicable (not included in filter)	
	Blank	No answer	
207	LIMTRANS	<i>The health condition(s) or disease(s) or difficulty(ies) cause(s) the person's limitation in getting to and from work</i>	Everybody aged 15 to 64 and (HEALTHMA = 1-17 or DIFFICMA = 1-10)
	1	Yes, the health condition(s) or disease(s)	
	2	Yes, the activity difficulty(ies)	
	3	Yes, both, the health condition(s)/disease(s) and the activity difficulty(ies)	
	4	No	
	9	Not applicable (not included in filter)	
	Blank	No answer	
208	NEEDHELP	<i>Because of the health condition(s)/disease(s) or activity difficulty(ies) the person needs (not employed persons)/uses (employed persons personal assistance to enable him/her to work</i>	Everybody aged 15 to 64 and (HEALTHMA = 1-17 or DIFFICMA = 1-10)
	1	Yes	
	2	No	
	9	Not applicable (not included in filter)	
	Blank	No answer	
209	NEEDADAP	<i>Because of the health condition(s)/disease(s) or activity difficulty(ies) the person needs (not employed persons)/uses (employed persons special equipment or needs (not employed persons)/has (employed persons) workplace adaptations to enable him/her to work</i>	Everybody aged 15 to 64 and (HEALTHMA = 1-17 or DIFFICMA = 1-10)
	1	Yes	
	2	No	
	9	Not applicable (not included in filter)	
	Blank	No answer	

**Specifications of the 2011 ad hoc module on the employment of disabled people, cont'd**

210	NEEDORGA	<p><i>Because of the health condition(s)/disease(s) or activity difficulty(ies) the person needs (not employed persons)/has (employed persons) special working arrangements to enable him/her to work (such as sedentary jobs, teleworking, flexible hours or less strenuous work),</i></p> <p>1 Yes 2 No 9 Not applicable (not included in filter) Blank No answer</p>	Everybody aged 15 to 64 and (HEALTHMA = 1-17 or DIFFICMA = 1-10)
211/212	LIMREAS	<p><i>Main reason for limitation in work (number of hours, type, getting to and from work) that is not caused by the longstanding health conditions/diseases or basic activity difficulties</i></p> <p>01 Lack of qualifications/experience 02 Lack of appropriate job opportunities 03 Lack or poor transportation to and from workplace 04 Employers' lack of flexibility 05 Affects receipt of benefits 06 Family/caring responsibilities 07 Personal reasons 08 Other reason 09 No limitation in work 99 Not applicable (not included in filter) Blank No answer</p>	Everybody aged 15 to 64
213/218		<p><i>Weighting factor for the 2011 ad hoc module (optional)</i></p> <p>Columns 213-216 contain whole numbers Columns 217-218 contain decimal places</p>	

HEALTHMA (EHLTHM) Type of longstanding health condition or disease (main type)  
 (Eurostat AHM 2011 Col 197-198)

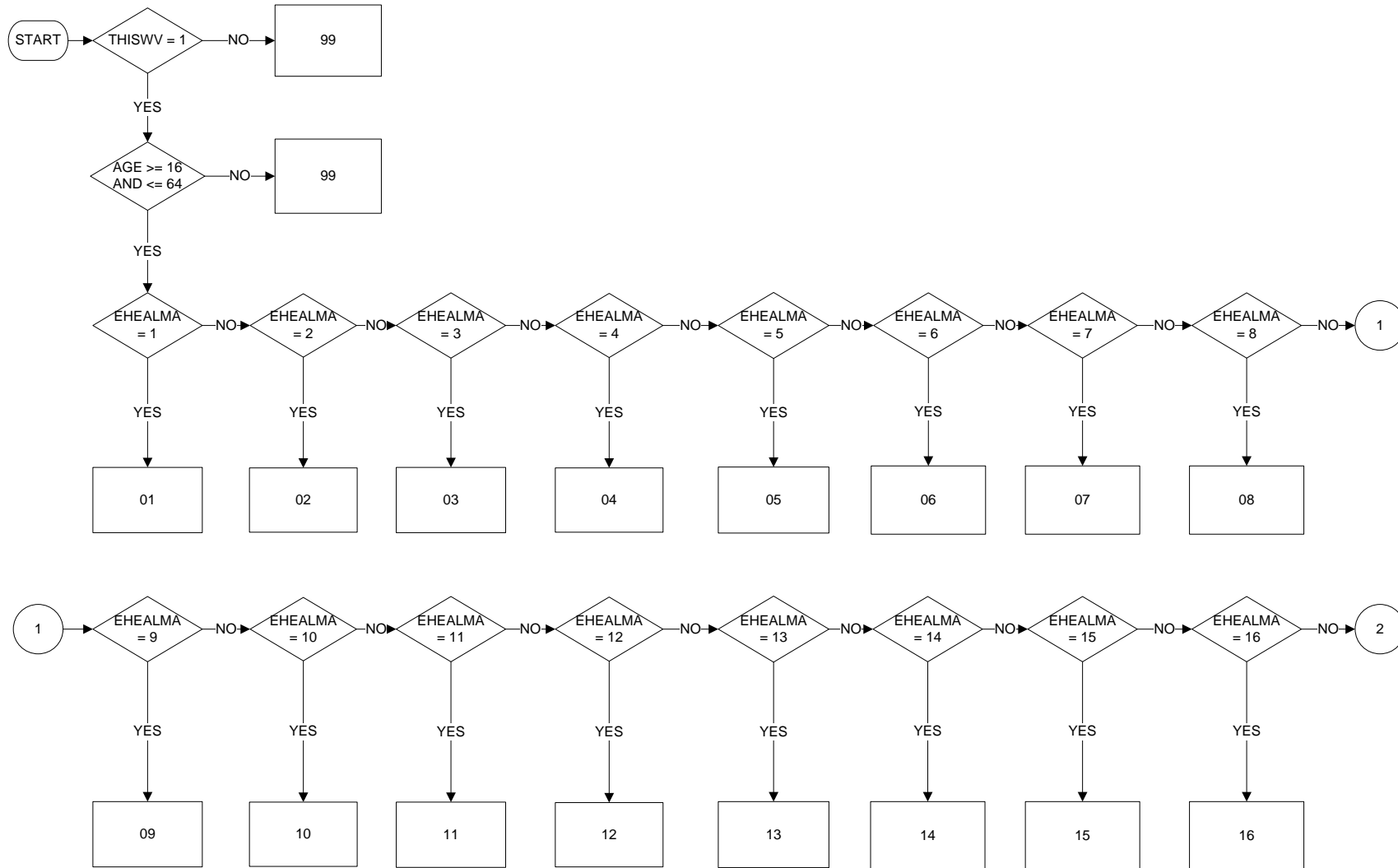

HEALTHMA (EHLTHM) Type of longstanding health condition or disease (main type)  
(Eurostat AHM 2011 Col 197-198)

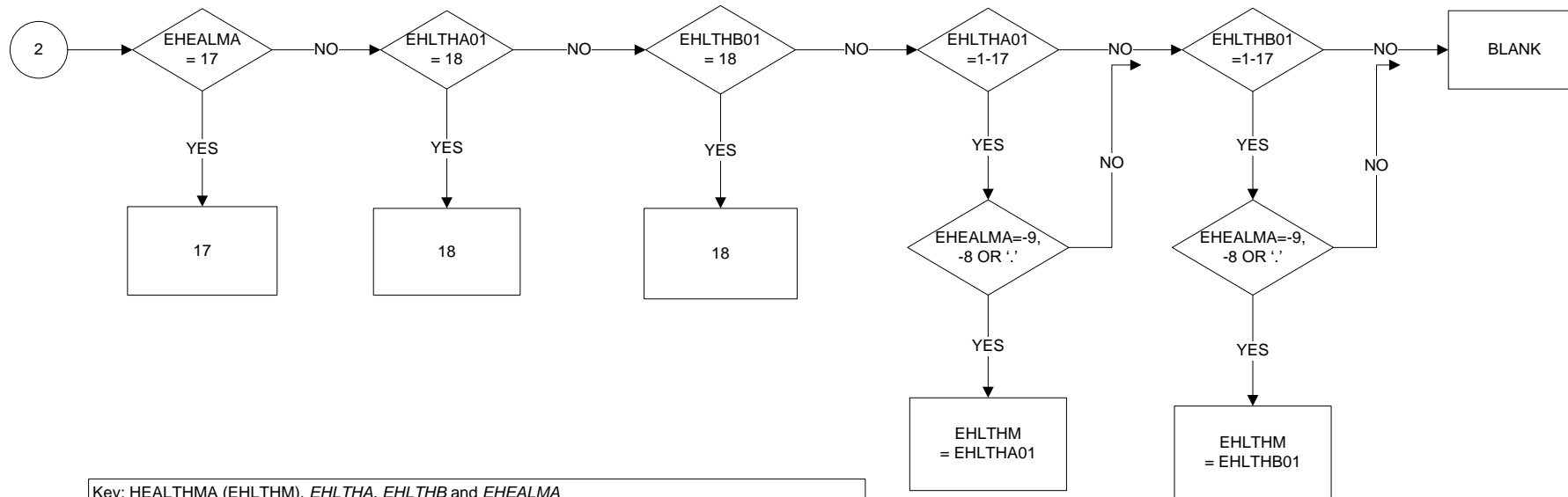

- Key: HEALTHMA (EHLTHM), *EHLTHA*, *EHLTHB* and *EHEALMA*
- 01 Problems with arms or hands (includes arthritis or rheumatism)
  - 02 Problems with legs or feet (includes arthritis or rheumatism)
  - 03 Problems with back or neck (includes arthritis or rheumatism)
  - 04 Cancer
  - 05 Skin conditions, including allergic reactions and severe disfigurement
  - 06 Heart, blood pressure or circulation problems
  - 07 Chest or breathing problems, including asthma and bronchitis
  - 08 Stomach, liver, kidney or digestive problems
  - 09 Diabetes
  - 10 Epilepsy (includes fits)
  - 11 Severe headaches such as migraine
  - 12 Learning difficulties (reading, spelling or math disability)
  - 13 Chronic anxiety
  - 14 Depression
  - 15 Other mental, nervous or emotional problem
  - 16 Other progressive illness (includes multiple sclerosis, HIV, Alzheimer's disease, Parkinson's disease)
  - 17 Other longstanding health problems
  - 18 No longstanding health conditions or diseases
  - 99 Not applicable (not included in filter)

*EHLTHA* You have already said that you have health problems or disabilities that you expect will last for more than a year. Now thinking about health conditions or diseases that you expect to last for at least six months, do you have...

*EHLTHB* You have already said that you do not have health problems or disabilities that you expect will last for more than a year. Now thinking about health conditions or diseases that you expect to last for at least six months, do you have...

*EHEALMA* Which of these health conditions or diseases would you say has the greatest impact on your life



HEALTHSE (EHLTHS) Type of longstanding health condition or disease (second main type)  
 (Eurostat AHM 2011 Col 199-200)

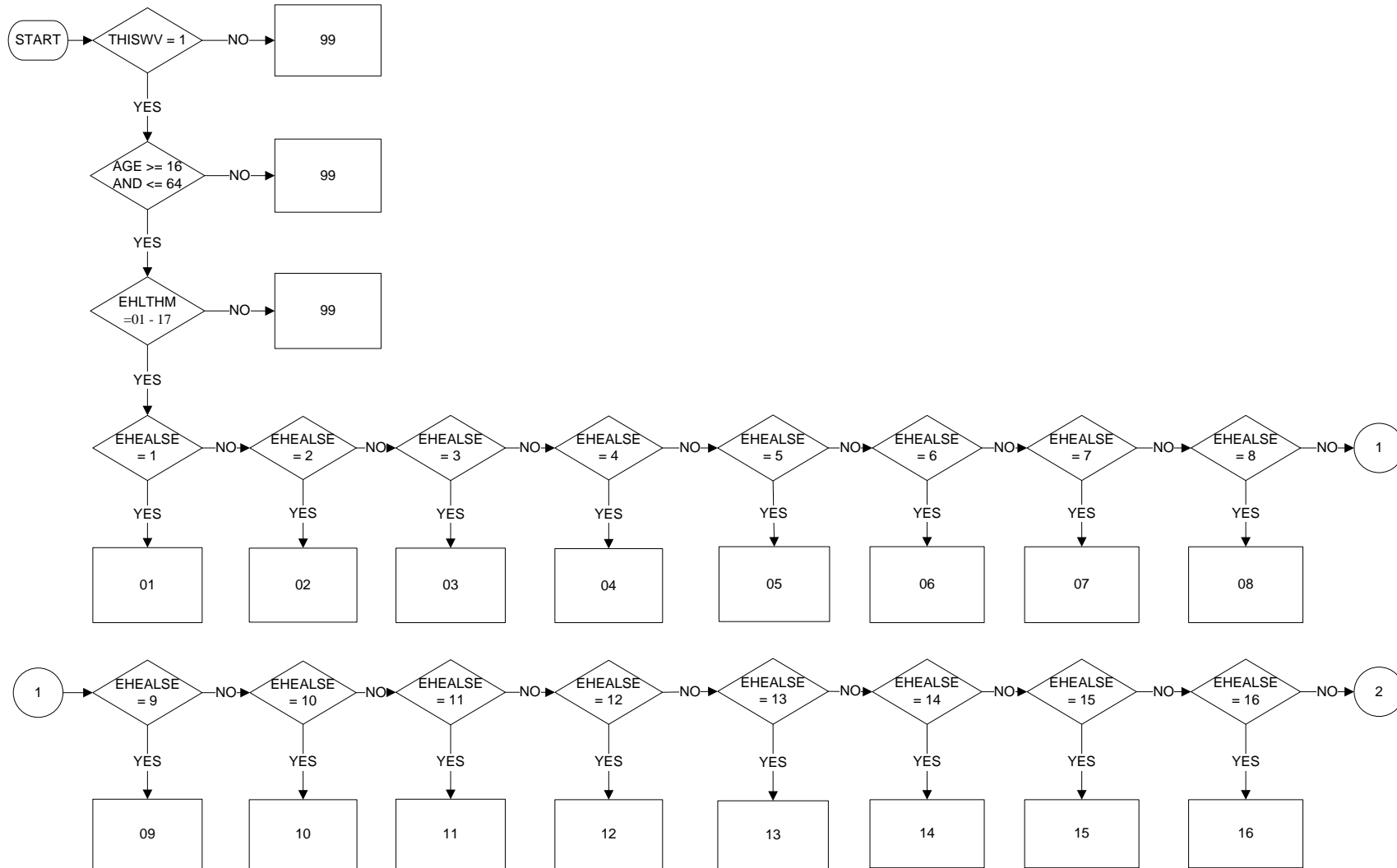

HEALTHSE (EHLTHS) Type of longstanding health condition or disease (second main type)  
(Eurostat AHM 2011 Col 199-200)

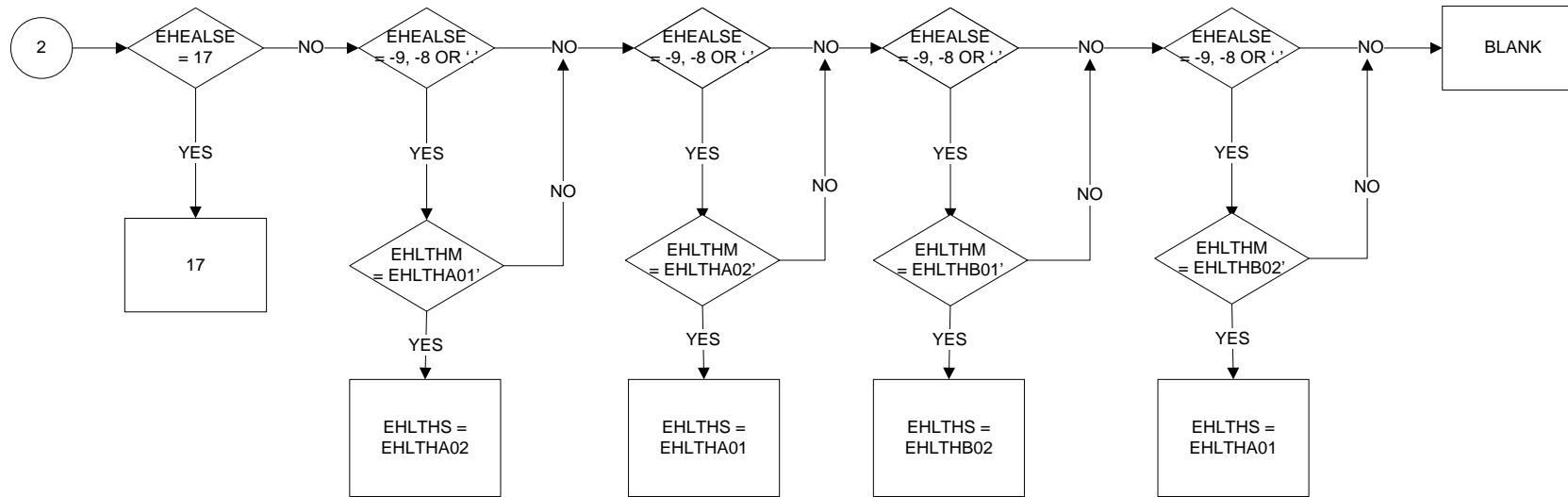

- Key: HEALTHSE (EHLTHM), *EHLTHS*, *EHLTHB* and *EHEALSE*
- 01 Problems with arms or hands (includes arthritis or rheumatism)
  - 02 Problems with legs or feet (includes arthritis or rheumatism)
  - 03 Problems with back or neck (includes arthritis or rheumatism)
  - 04 Cancer
  - 05 Skin conditions, including allergic reactions and severe disfigurement
  - 06 Heart, blood pressure or circulation problems
  - 07 Chest or breathing problems, including asthma and bronchitis
  - 08 Stomach, liver, kidney or digestive problems
  - 09 Diabetes
  - 10 Epilepsy (includes fits)
  - 11 Severe headaches such as migraine
  - 12 Learning difficulties (reading, spelling or math disability)
  - 13 Chronic anxiety
  - 14 Depression
  - 15 Other mental, nervous or emotional problem
  - 16 Other progressive illness (includes multiple sclerosis, HIV, Alzheimer's disease, Parkinson's disease)
  - 17 Other longstanding health problems
  - 18 No longstanding health conditions or diseases
  - 99 Not applicable (not included in filter)

*EHLTHA* You have already said that you have health problems or disabilities that you expect will last for more than a year. Now thinking about health conditions or diseases that you expect to last for at least six months, do you have...

*EHLTHB* You have already said that you do not have health problems or disabilities that you expect will last for more than a year. Now thinking about health conditions or diseases that you expect to last for at least six months, do you have...

*EHEALSE* Which of these health conditions or diseases would you say has the second greatest impact on your life

DIFFICMA (EDIFFM) First basic activity difficulty (Eurostat AHM 2011 Col 201-202)

Start date: Jan 2011  
End date: Dec 2011

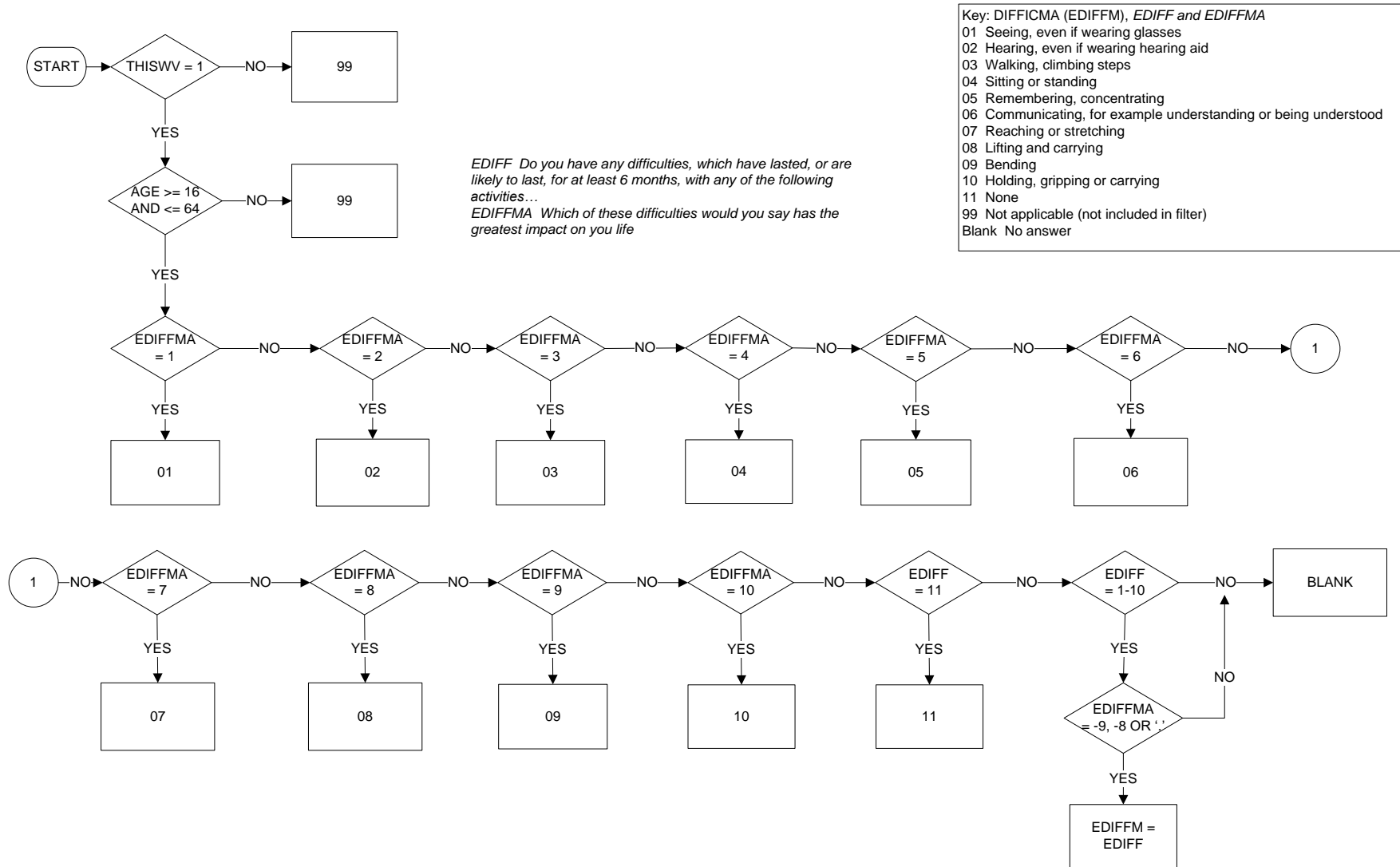

DIFFICSE (EDIFFS) Second basic activity difficulty (Eurostat AHM 2011 Col 203-204)

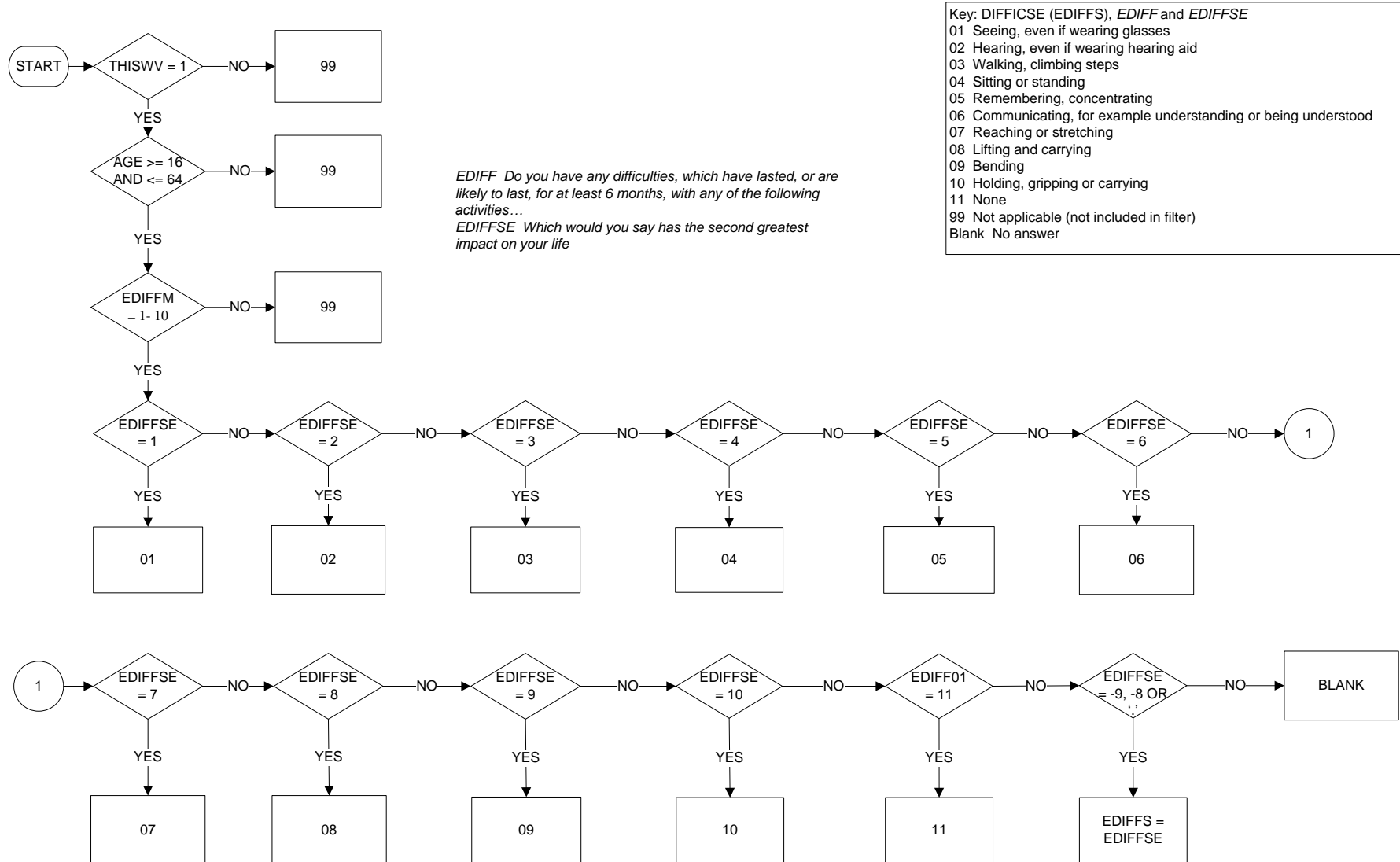

LIMHOURS (ELIMHRSE) The health condition/disease or activity difficulty causes limitations in the number of hours (Eurostat AHM 2011 Col 205)

Start date: Jan 2011  
End date: Dec 2011

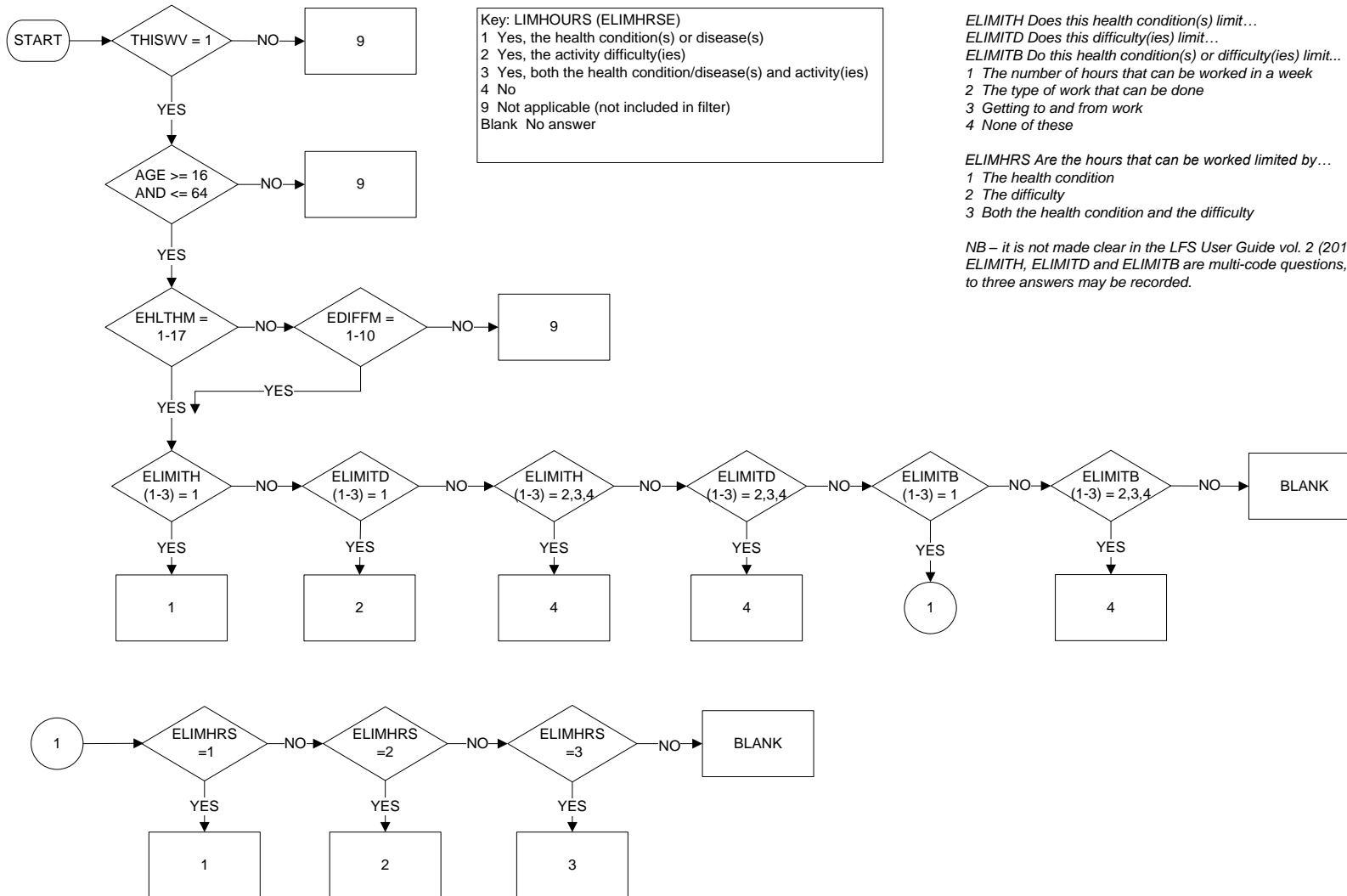

LIMTYPEW (ELIMTYPE) The health condition/disease or activity difficulty limits the type of work  
(Eurostat AHM 2011 Col 206)

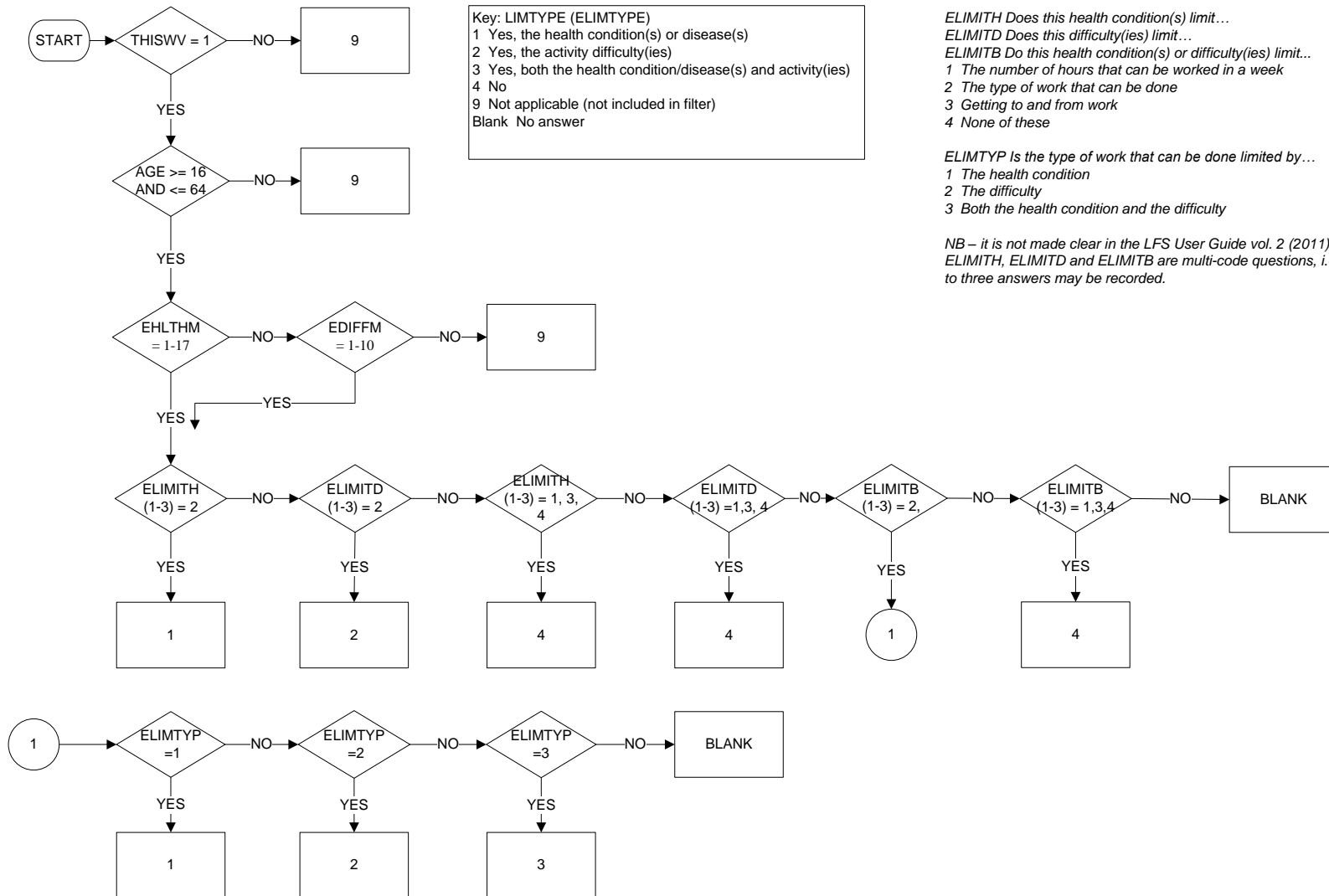

LIMTRANS (ELIMTRA) The health condition/disease or activity difficulty limits the transport to work  
(Eurostat AHM 2011 Col 207)

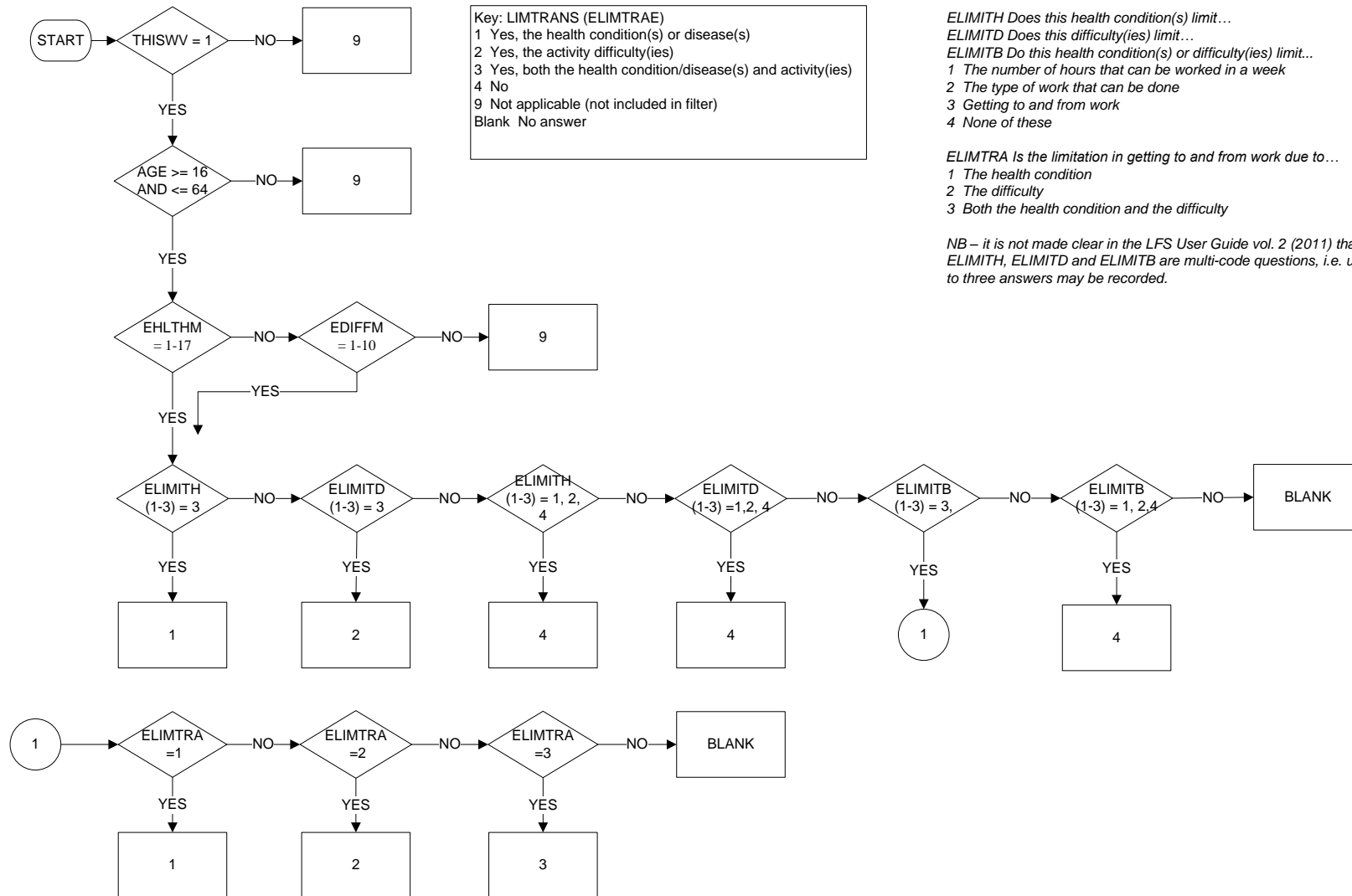

NEEDHELP (ENEEDHLP) Whether person needs/uses personal assistance to enable them to work  
(Eurostat AHM 2011 Col 208)

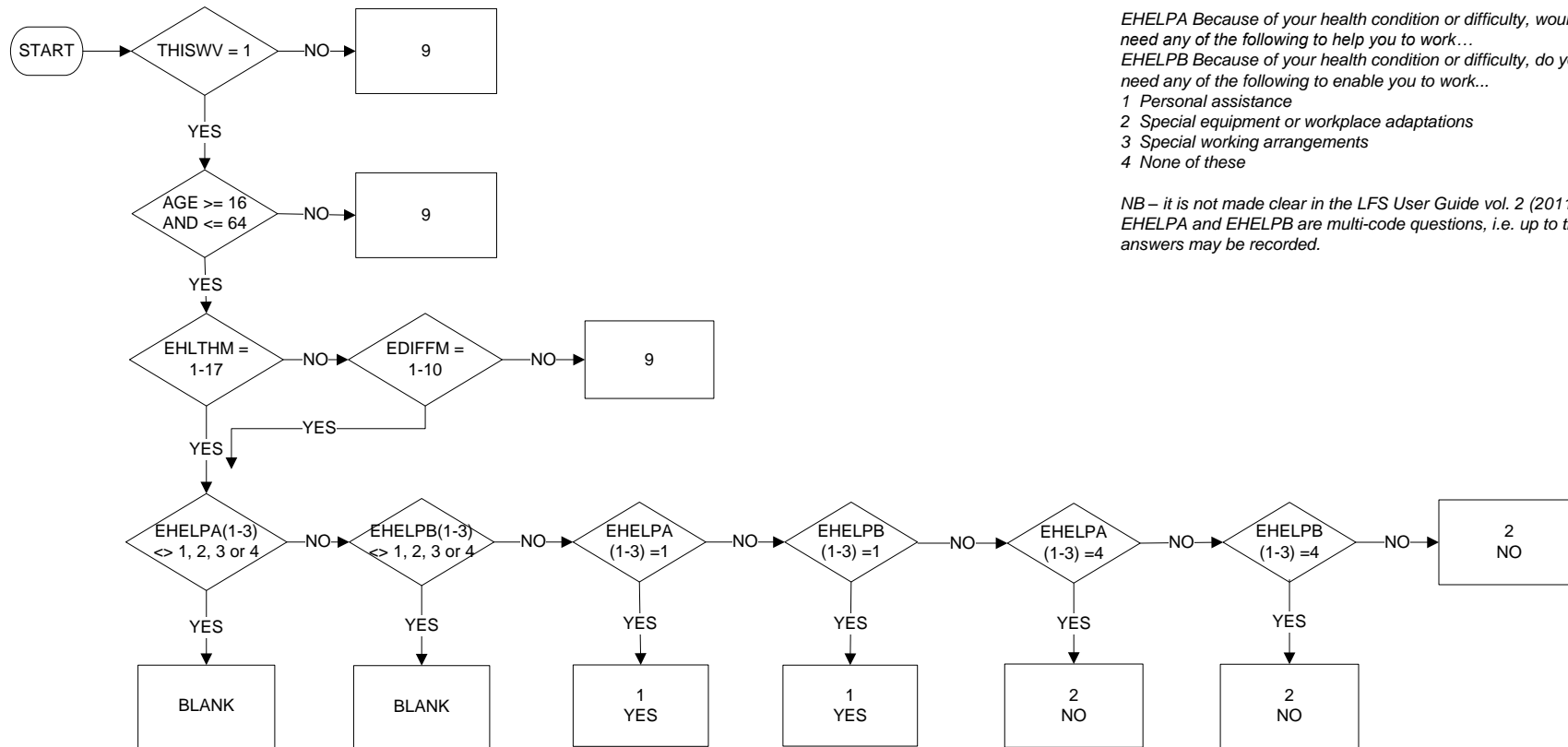

*EHELPA* Because of your health condition or difficulty, would you need any of the following to help you to work...  
*EHELPB* Because of your health condition or difficulty, do you need any of the following to enable you to work...  
 1 Personal assistance  
 2 Special equipment or workplace adaptations  
 3 Special working arrangements  
 4 None of these

*NB* – it is not made clear in the LFS User Guide vol. 2 (2011) that *EHELPA* and *EHELPB* are multi-code questions, i.e. up to three answers may be recorded.



NEEDADAP (ENEEDAD) Whether person needs/uses workplace adaptations to enable them to work  
(Eurostat AHM 2011 Col 209)

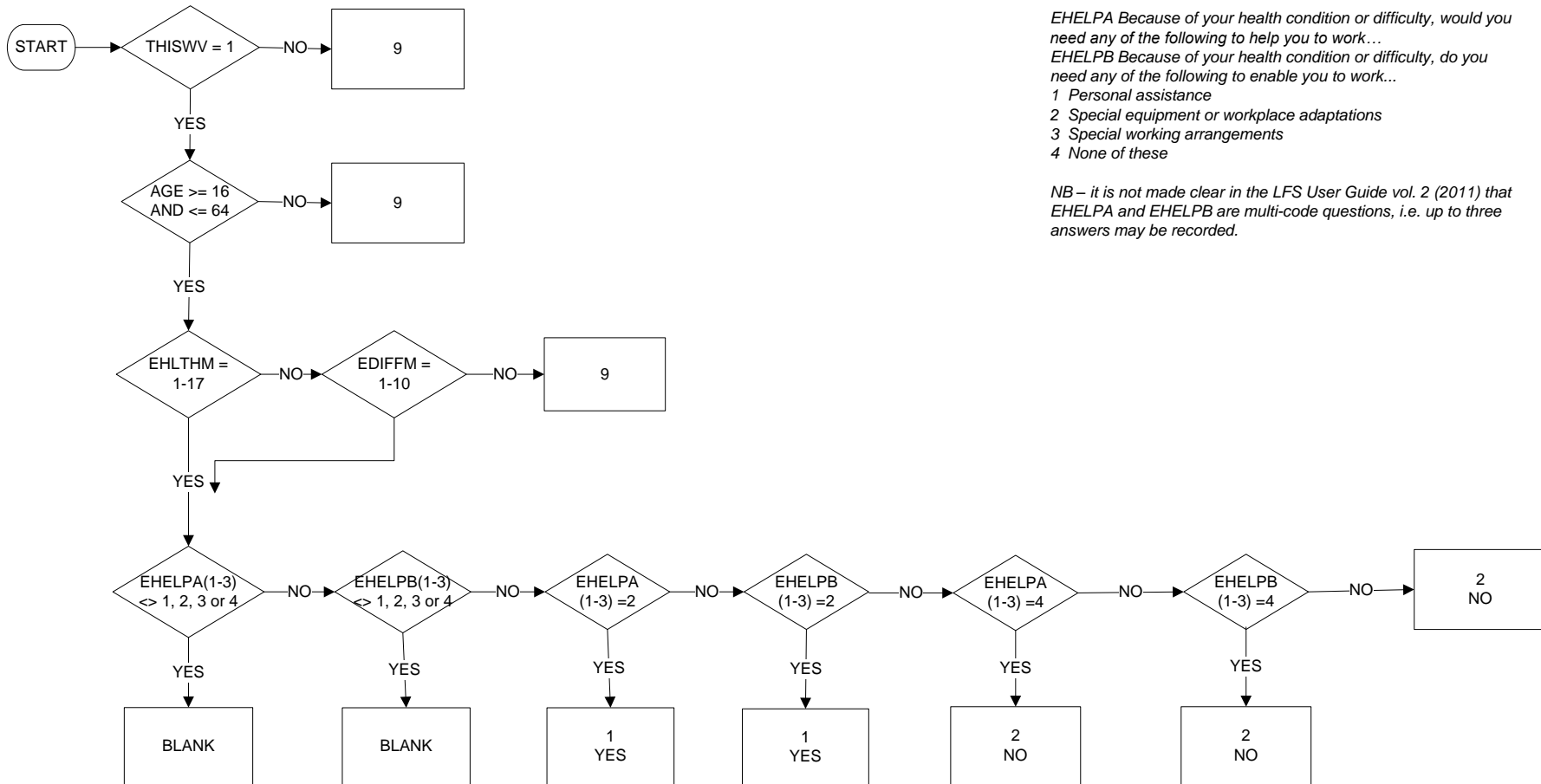

NEEDORGA (ENEEDOR) Whether person needs/has special working arrangements to enable them to work (Eurostat AHM 2011 Col 210)

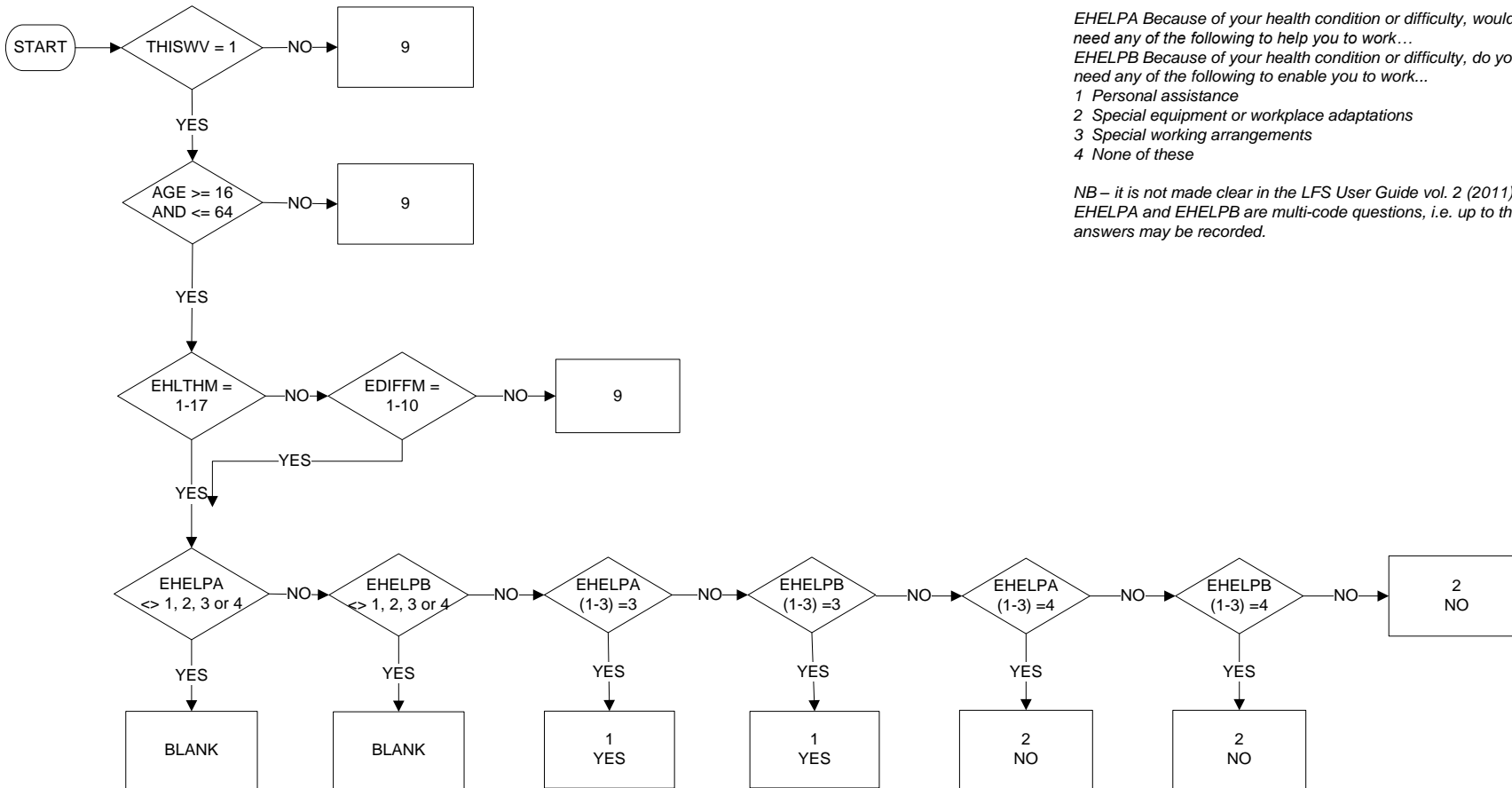

EHELPA Because of your health condition or difficulty, would you need any of the following to help you to work...  
EHELPB Because of your health condition or difficulty, do you need any of the following to enable you to work...  
1 Personal assistance  
2 Special equipment or workplace adaptations  
3 Special working arrangements  
4 None of these

NB – it is not made clear in the LFS User Guide vol. 2 (2011) that EHELPA and EHELPB are multi-code questions, i.e. up to three answers may be recorded.

LIMREAS (ELIMREAS) Main reason for limitation in work  
(Eurostat AHM 2011 Col 211/212)

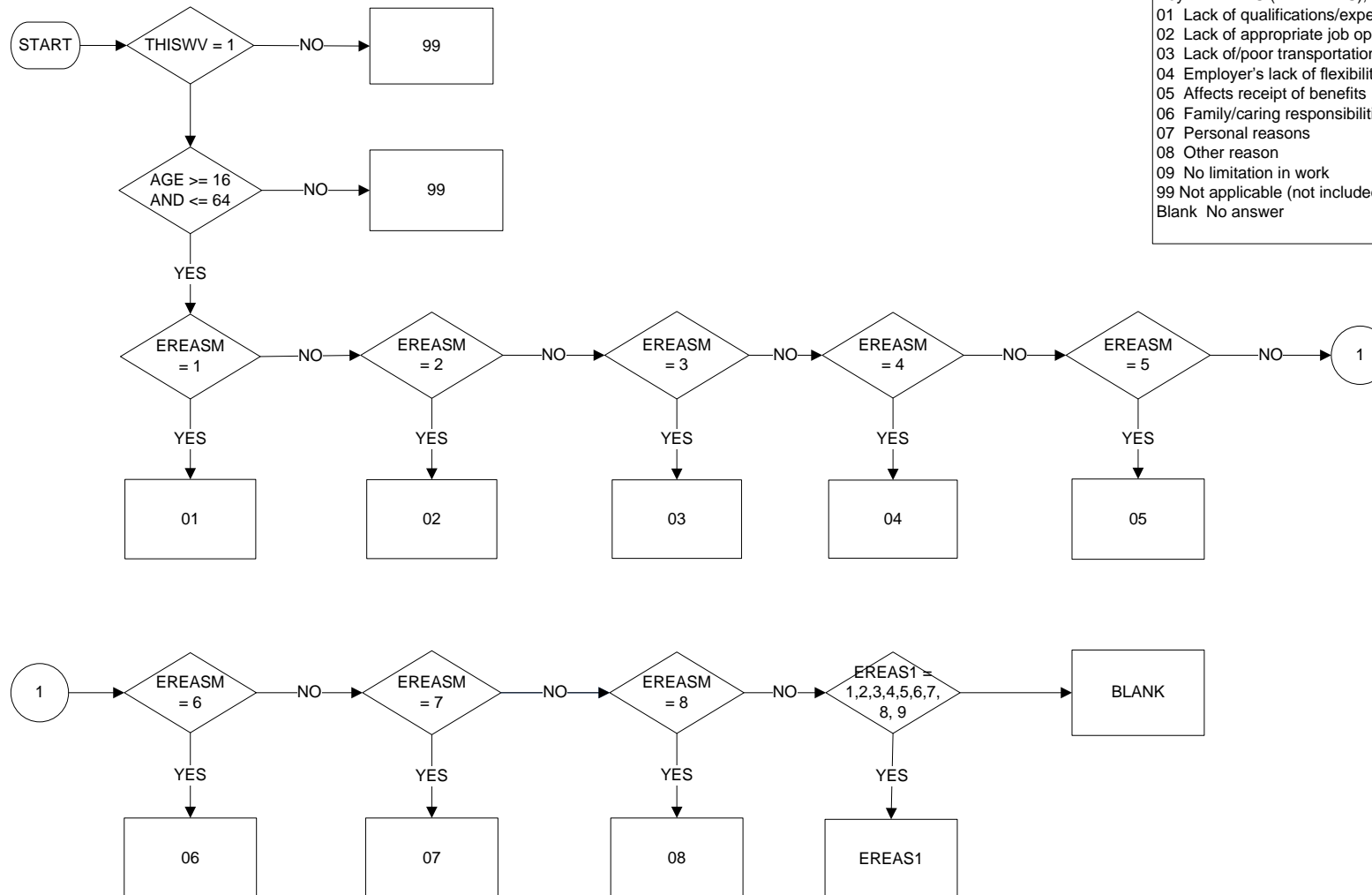

Key: LIMREAS (ELIMREAS), *EREAS* and *EREASM*  
 01 Lack of qualifications/experience  
 02 Lack of appropriate job opportunities  
 03 Lack of/poor transportation to and from workplace  
 04 Employer's lack of flexibility  
 05 Affects receipt of benefits  
 06 Family/caring responsibilities  
 07 Personal reasons  
 08 Other reason  
 09 No limitation in work  
 99 Not applicable (not included in filter)  
 Blank No answer

## **Explanatory Notes for the variables of the 2011 LFS ad hoc module**

### **Focus of the 2011 LFS ad hoc module**

#### ***1. Aim of the module***

According to the policy needs and taking into account the constraint regarding the final number of variables for the module, the aim of the module is to provide information on the situation on the labour market of disabled people. The module is not designed to measure the prevalence of disability in the population.

**Target population:** persons aged 15-64 years old

(NB - Persons aged 15 are considered as inactive in ES, IT and the UK. Consequently, the target population for this module will be 16-64.)

#### ***2. User needs and requests proposed by DG Employment and the European Disability***

##### ***Forum (EDF)***

The 2011 module is an opportunity to measure the situation of disabled people on the labour market and to compare it with the situation of non disabled people. The results obtained should help in monitoring the employment situation of disabled people with a view to:

- examine the existing situation
- identify any possible domains/issues where improvements would be required
- highlight successful policies
- make suggestions for policies which need to be developed further

#### ***3. Experience of the 2002 module on employment of disabled people***

The 2002 module experience revealed that filtering the disability population using a single question on longstanding health problems and disability was inefficient. It reduced significantly comparability across countries. It is therefore important to investigate in more details health problems and difficulties in basic activities (separately and by listing diseases and basic activities) so that respondents do not “forget” to mention any of their problems.

#### ***4. Limited number of variables***

The constraint of a maximum of 11 variables implies that variables remain general, applicable to all types of disability and all types of situations.

#### ***5. Attempt to implement the current concept of disability***

The objective was to implement, as far as possible, the current concept of disability as defined by the International Classification of Functioning, Disability and Health (ICF, WHO, 2001), also called the Biosocial concept. According to this model, disability results from the effect of the environment and barriers to independent living or educational, employment or other opportunities that impact on people with impairments, ill health or activity difficulties.

According to this concept,

- questions have to be designed so that health problems and difficulties in basic activities are asked separately,
- limitations in work should not be directly linked to health issues,

- limitations in work should be viewed in the context of interaction between the environment and the person.

However, it appeared that this way of thinking is difficult to implement and operationalise in a questionnaire, in particular in the context of the Labour Force Survey within a limited number of variables.

### **6. Content and structure of the module**

The variables of the 2011 module correspond to the following topics:

- Health problems and difficulties in basic activities (difficulties in seeing, hearing, walking, etc.)
- Limitations in work caused by health problems/difficulties in basic activities
- Special assistance needed or used by people with health problems/difficulties in basic activities
- Limitations in work because of other reasons (family/care responsibilities, lack of qualification/experience, etc.)

Remarks on the final structure of the module:

- The structure of the final proposal is a trade-off between pragmatic factors and the attempt to approach, as far as possible, the current concept of disability.
- Contrary to the 2002 module, health problems and difficulties in basic activities are asked separately. Following the LAMAS' recommendation, these questions are put at the very beginning of the module with a short preamble to introduce.
- Then, for pragmatic reasons, restrictions in participation in the labour market (limitations in work) are linked to health/difficulties in basic activities. However, to approach the ICF philosophy and to reflect the interaction between limitations in work and the environment of the person, a question on other reasons for limitations in work is added.
- This final structure of the 2011 module presents the advantage to have very simple filters.

### **PREAMBLE introducing the module**

*The following questions aim at identifying the extent to which people are limited in their work and the nature or type of this limitation. Let's start with health.*

This preamble shall be read to the respondent. It briefly clarifies the main objectives of the module to be reached through the proposed set of variables.

## **1. SPECIFIC HEALTH CONDITIONS OR DISEASES**

### **HEALTHMA / COL. 197-198**

#### **Short description**

Type of longstanding health condition or disease (1<sup>st</sup> P main type)

#### **Filter**

Everybody aged 15-64

### Codes

- 01 Problems with arms or hands (which includes arthritis or rheumatism)
  - 02 Problems with legs or feet (which includes arthritis or rheumatism)
  - 03 Problems with back or neck (which includes arthritis or rheumatism)
  - 04 Cancer
  - 05 Skin conditions, including allergic reactions and severe disfigurement
  - 06 Heart, blood pressure or circulation problems
  - 07 Chest or breathing problems, including asthma and bronchitis
  - 08 Stomach, liver, kidney or digestive problems
  - 09 Diabetes
  - 10 Epilepsy (include fits)
  - 11 Severe headache such as migraine
  - 12 Learning difficulties (reading, spelling or math disability)
  - 13 Chronic anxiety
  - 14 Depression
  - 15 Other mental, nervous or emotional problems
  - 16 Other progressive illnesses (which include multiple sclerosis, HIV, Alzheimer's disease, Parkinson's disease)
  - 17 Other longstanding health problems
  - 18 No longstanding health conditions or diseases
  - 99 Not applicable (not included in the filter)
- Blank No answer

### Purpose

The aim of HEALTHMA is to identify which, if any, of the longstanding health conditions or diseases (not necessarily diagnosed by a physician) that a person has is the main one (i.e. the one which the person considers as being the most severe). The list of longstanding health conditions and diseases is an aide memoire for respondents, as it makes them to think to the different kinds of physical, mental and emotional health problems. The items included in the list represent a mixture of problems associated with anatomical, physiological and psychological structures and functions.

### Definition

Longstanding means that the health condition or disease has lasted or is likely to last for at least 6 months. The main characteristics of a long standing condition or disease are that it is ispermanent and may be expected to require a long period of supervision, observation or care. Therefore, any acute (temporary) health problem, such as a sprained ankle, broken leg, appendicitis or a respiratory tract infection is not of interest. The criterion which has to be used in assessing the “main” longstanding health condition or disease is the impact that it has on the person's life.

### Examples:

- Person had a medical check-up 2 months ago and the doctor diagnosed him/her as having diabetes. Though his/her disease exists only for the last 2 months, it is high probable that his/her health problem is a longstanding health problem and it will be last for more than 6 months (Code 09).
- Person had a medical check-up 1 month ago and the doctor diagnosed him/her as having asthma. Though his/her illness is only 1 month it is evident that the condition will last longer than 6 months (Code 07).

However, an injury caused by an accident can be longstanding if its consequences last for at least 6 months. Example:

- Person with severe and complicated femur shaft fracture during the traffic accident. Time of treatment was 5 month and time of rehabilitation was 3 month.
  1. situation: The treatment and rehabilitation was at the time of survey. Because the time of treatment plus rehabilitation has been longer than 6 months, the person should be considered as having a longstanding health problem.
  2. situation: The treatment and rehabilitation were finished at the time of survey. But the person has a permanent side-effect. The person should be considered as having a longstanding health problem.
  3. situation: The treatment and rehabilitation was finished at the time of survey and person has not suffered a side-effect. Then code 18 should be used.

### Implementation rules

It should be noted that some terms might be replaced by ‘alternatives’. For instance:

- ‘chronic’ or ‘longstanding’ should be chosen according to what is ‘best understood’ in a country/language
- it seems that in some countries/languages it would be strange to use the word ‘have’ and ‘suffer’ is preferred (it has the same meaning as ‘have’ in some languages)

Some conditions are recurrent (e.g. back pain), where there is an acute period followed by remission; other conditions are episodic in nature (e.g. epilepsy, migraine). Both situations should be considered as longstanding health problems, as they are continual or continuous problems. If a person suffers from a terminal illness or if the length of illness is dependent on the outcome of treatment (e.g. cytoxin or radiation therapy), the corresponding code of the health condition or disease should be used.

If the respondent does not know how long their health problem is going to last, the interviewer must not make the decision; respondents should be encouraged to estimate how long they think their problem will last for taking account of any information given by doctors or other health professionals.

Even a person has/had a longstanding disease that doesn/didn’t bother him/her or it is/was kept under control with medication, he/she should consider it. For example, medication of a person suffering from mental problems can keep that person fully able to function and a diabetic can feel healthy on account of regular insulin treatment. These persons are, however, considered as having longstanding health problem as they would not manage without medication.

Remarks in relation to some of the conditions and diseases from the list:

- Skin conditions, including allergic reactions and severe disfigurement (code 05): severe disfigurements include major scars resulting from accidents, burns or frost-bites, birthmarks and diseases of the skin, including skin related allergies; exclude tattooing and body piercing.
- Heart, blood pressure or circulation problems (code 06): stroke is included
- Learning difficulties (code 12) are also known as mental handicap, mental impairment or mental retardation. Examples: dyslexia, dyscalculia.
- Other mental, nervous or emotional problems (code 15) include severe mental problem: psychosis (e.g. schizophrenia), affective disorders and clinically recognised less severe disorders (panic, phobias, anorexia, etc.).
- Obesity, alcohol and drug dependency should be considered as other longstanding health problems (code 17).

If the respondent does not have a longstanding health condition or disease, then code 18 is used and variable DIFFICMA is asked.

In the core part of the LFS there are 3 variables (FTPTREAS, LEAVREAS and SEEKREAS)

which have "own illness or disability" as answer category. In case the answer provided by a respondent to any of these 3 variables is "own illness or disability", then the interviewer should expect that a health problem is declared in HEALTHMA or a difficulty in a basic activity is declared in DIFFICMA. If the respondent does not report any health problem (in HEALTHMA) or difficulty in basic activities (in DIFFICMA), then the interviewer should remind the respondent his/her previous answer and ask for details. On the basis of the respondent's answer and the definitions in HEALTHMA and DIFFICMA, the interviewer should decide what code to use for these 2 variables.

## **HEALTHSE Col 199/200**

### **Short description**

Type of longstanding health condition or disease (2<sup>nd</sup> main type)

### **Filter**

Everybody aged 15-64 and HEALTHMA = 1-17.

### **Codes**

- 01 Problems with arms or hands (which includes arthritis or rheumatism)
  - 02 Problems with legs or feet (which includes arthritis or rheumatism)
  - 03 Problems with back or neck (which includes arthritis or rheumatism)
  - 04 Cancer
  - 05 Skin conditions, including allergic reactions and severe disfigurement
  - 06 Heart, blood pressure or circulation problems
  - 07 Chest or breathing problems, including asthma and bronchitis
  - 08 Stomach, liver, kidney or digestive problems
  - 09 Diabetes
  - 10 Epilepsy (include fits)
  - 11 Severe headache such as migraine
  - 12 Learning difficulties (reading, spelling or math disability)
  - 13 Chronic anxiety
  - 14 Depression
  - 15 Other mental, nervous or emotional problems
  - 16 Other progressive illnesses (which include multiple sclerosis, HIV, Alzheimer's disease, Parkinson's disease)
  - 17 Other longstanding health problems
  - 18 No other longstanding health conditions or diseases
  - 99 Not applicable (not included in the filter)
- Blank No answer

### **Purpose**

This variable (HEALTHSE) aims at identifying a 2<sup>nd</sup> P longstanding health conditions or diseases (not necessarily diagnosed by a physician) that a person has (i.e. the one which the person considers as being the 2<sup>nd</sup> as concerns the severity).

### **Definition**

See HEALTHMA



### **Implementation rules**

See HEALTHMA

## **2. DIFFICULTIES IN BASIC ACTIVITIES**

### **DIFFICMA Col 201/202**

#### **Short description**

1<sup>st</sup> basic activity difficulty (the most important difficulty)

#### **Filter**

Everybody aged 15-64

#### **Codes**

- 01 Seeing, even if wearing glasses
  - 02 Hearing, even if using a hearing aid
  - 03 Walking, climbing steps
  - 04 Sitting or standing
  - 05 Remembering, concentrating
  - 06 Communicating, for example understanding or being understood
  - 07 Reaching or stretching
  - 08 Lifting and carrying
  - 09 Bending
  - 10 Holding, gripping, or turning
  - 11 None
  - 99 Not applicable (not included in the filter)
- Blank No answer

#### **Purpose**

The variable DIFFICMA allows the identification of the basic activity which causes the person most difficulties in coping with his/her everyday life. It captures a wide range of physical, sensory and mental limitations.

#### **Definition**

An activity is defined as: 'the performance of a task or action by an individual' and thus activity difficulties are defined as 'the difficulties the individual experience in performing an activity'. The criterion which has to be used in assessing "most" difficulty is the impact that it has on the person's life. Only long-term difficulties in basic activities should be considered. Therefore, the length of difficulty must have lasted or be expected to last for six months or more.

#### **Implementation rules**

When answering, the use of technical devices/aids or assistance should not be considered except for seeing and hearing (codes 1 and 2). For instance eyesight problems should not be reported if glasses or contact lenses are 'sufficiently effective'. The activities from the list refer to difficulties in the physical act of doing them, and not for difficulties due to other functioning problems. For example, a blind person (using or not a walking stick or a guide dog) should not be seen as having walking difficulties.

Even the respondent seems to be permanently confined to bed or completely deaf or blind, it is preferable that this variable is not skipped for him/her. 'Communicating, for example understanding or being understood' (code 6) refers to problems in using or understanding the mother tongue and not a foreign language. To grip (code 10) means to take firmly with the hand and maintain a hold on.

## **DIFFICSE Col 203/204**

### **Short description**

2<sup>nd</sup> P basic activity difficulty (the second most important difficulty)

### **Filter**

Everybody aged 15-64 and DIFFICMA = 1–10

### **Codes**

- 01 Seeing, even if wearing glasses
  - 02 Hearing, even if using a hearing aid
  - 03 Walking, climbing steps
  - 04 Sitting or standing
  - 05 Remembering, concentrating
  - 06 Communicating, for example understanding or being understood
  - 07 Reaching or stretching
  - 08 Lifting and carrying
  - 09 Bending
  - 10 Holding, gripping, or turning
  - 11 None
  - 99 Not applicable (not included in the filter)
- Blank No answer

### **Purpose**

The variable DIFFICSE allows the identification of the basic activity which causes the person the second most difficulty in coping with his/her everyday life.

### **Definition**

See DIFFICMA

### **Implementation rules**

See DIFFICMA

## **3. LIMITATIONS IN WORKING ACTIVITIES**

The aim of the following three variables is to investigate how people's longstanding health conditions or diseases or difficulties in basic activities interfere with the work that they can do. The variable examines the effect of the longstanding health conditions or diseases or difficulties in the context of work.

## **LIMHOURS Col 205**

### **Short description**

The health condition(s) or disease(s) or difficulty(ies) cause(s) the person's limitation in the number of hours that he/she can work in a week.

### Filter

Everybody aged 15-64 and (HEALTHMA = 1–17 or DIFFICMA = 1–10)

### Codes

- 1 Yes, the health condition(s) or disease(s)
- 2 Yes, the activity difficulty(ies)
- 3 Yes, both, the health condition(s)/disease(s) and the activity difficulty(ies)
- 4 No
- 9 Not applicable (not included in the filter)
- Blank No answer

### Purpose

This variable aims at identifying whether the people are limited in the number of hours that they can work because of the longstanding health conditions or diseases or difficulties in basic activities they have. A filter is introduced, ensuring that only those declaring a longstanding health condition or disease or basic activity difficulty are asked to provide an answer.

### Definition

The interviewed person should think whether the nature of his/her limitation in the number of hours that he/she can work in a week is caused (totally or partly) by the longstanding health conditions or diseases or difficulties in basic activities that he/she has. The term 'number of hours' is used here to reflect the amount of work.

The limitation in the number of hours covers the frequency of its impact (all the time, daily, weekly, monthly etc.) and the severity of its impact (not at all, to some extent etc.).

### Implementation rules

The respondents do not necessarily face the situation proposed (the reference here is a fulltime working schedule) and so the limitation is measured in terms of capacity to undertake the task (he/she can work) rather than performance (he/she does). The aim of the question is to assess the person's own capacity.

Code 4 "No" corresponds to the situation when the health condition(s)/disease(s) or activity difficulty(ies) that the respondent has is/are not causing him/her a limitation in the number of hours that he/she can work in a week.

## LIMTYPEW Col 206

### Short description

The health condition(s) or disease(s) or difficulty(ies) causes(s) the person's limitation in the type of work (for instance, having problems in carrying heavy loads, working outdoors, sitting for a long time) that he/she can do

### Filter

Everybody aged 15-64 and (HEALTHMA = 1–17 or DIFFICMA = 1–10)

### Codes

- 1 Yes, the health condition(s) or disease(s)
- 2 Yes, the activity difficulty(ies)
- 3 Yes, both, the health condition(s)/disease(s) and the activity difficulty(ies)
- 4 No
- 9 Not applicable (not included in the filter)
- Blank No answer

### Purpose

This variable aims at identifying whether the people are limited in the type of work that they can work because of the longstanding health conditions or diseases or difficulties in basic activities they have.

A filter is introduced, ensuring that only those declaring a longstanding health condition or disease or basic activity difficulty are asked to provide an answer.

### Definition

The interviewed person should think whether the nature of his/her limitation in the type of work that he/she can do is caused (totally or partly) by the longstanding health conditions or diseases or difficulties in basic activities that he/she has.

The limitation in the type of work covers the frequency of its impact (all the time, daily, weekly, monthly etc.) and the severity of its impact (not at all, to some extent etc.).

### Implementation rules

Being limited in type of work covers, for example: having problems with carrying heavy loads, not being able to work outdoors or indoors, not being able to sit down for a long time as well as not having the appropriate skills and training. It should be noted that the limitation is measured in terms of capacity to do specific kind of work.

Examples:

- A person cannot work in 'public relations' because of the severe scar that he/she has on his/her face;
- A person using the wheelchair works at a reception desk but he/she would like to do something else;
- A person is suffering from the chronic back pain, but he/she successfully works in the office (without limitations). However, due to the mentioned health problem, he/she definitely would not be able to perform the physical work in the construction.

Code 4 "No" corresponds to the situation when the health condition(s)/disease(s) or activity difficulty(ies) that the respondent has is/are not causing him/her a limitation in the type of work that he/she can do.

## LIMTRANS Col 207

### Short description

The health condition(s) or disease(s) or difficulty(ies) cause(s) the person's limitation in getting to and from work

### Filter

Everybody aged 15-64 and (HEALTHMA = 1–17 or DIFFICMA = 1–10)

### Codes

- 1 Yes, the health condition(s) or disease(s)
- 2 Yes, the activity difficulty(ies)
- 3 Yes, both, the health condition(s)/disease(s) and the activity difficulty(ies)
- 4 No
- 9 Not applicable (not included in the filter)
- Blank No answer

### Purpose

This variable aims at identifying whether the people are limited in getting to and from work because of the longstanding health conditions or diseases or difficulties in basic activities they have.

A filter is introduced, ensuring that only those declaring a longstanding health condition or disease or basic activity difficulty are asked to provide an answer.

### Definition

The interviewed person should think whether the nature of his/her limitation in getting to and from work is caused (totally or partly) by the longstanding health conditions or diseases or difficulties in basic activities that he/she has.

The limitation in getting to and from work covers the frequency of its impact (all the time, daily, weekly, monthly etc.) and the severity of its impact (not at all, to some extent etc.).

### Implementation rules

The interest is in the journey to and from work. Due to the health problem or difficulty in basic activities, a person may be limited in getting to and from a workplace (for instance, this person might have problems with the access to buildings, the availability of transport, difficulty getting on and off transport, or nobody is available to accompany them).

It should be noted that the limitation is measured in terms of capacity to go and return to/from work.

The provided assistance/adaptations should not be taken into account in this variable.

Code 4 "No" corresponds to the situation when the health condition(s)/disease(s) or activity difficulty(ies) that the respondent has is/are not causing him/her a limitation in getting to and from work.

## 4. SPECIAL ASSISTANCE USED OR NEEDED

The purpose of the following three variables is to identify the persons who because of the health problem or difficulty use/need special assistance or arrangements in order to help them to work. They allow finding out if especially people with health problems/difficulties are supported in their work, or - if not working - would need support in order to work. The variables are asked to both employed and non-employed respondents and therefore, the wording has to be adapted to each specific situation ("need" for those not employed and "use" or "have" for those employed). The types of assistance/arrangements are described in general terms and they can be regarded as methods to remove barriers to participation in work.

All three variables are asked of those with health problems or difficulties in basic activities. Therefore, these variables refer to special assistance or specialised equipment or special adaptations to the work environment for people in such circumstances.

The term 'assistance' refers to special personal assistance (from family members, relatives, friends, colleagues or other persons), organisational and environmental changes (special equipment/workplace adaptations, and special working arrangement) which help a person carrying out work activities.

### **NEEDHELP Col 208**

#### **Short description**

Because of the health problem or difficulty the person needs (not employed persons)/uses (employed persons) personal assistance to enable him/her to work

#### **Filter**

Everybody aged 15-64 and (HEALTHMA = 1–17 or DIFFICMA = 1–10)

#### **Codes**

1 Yes

2 No

9 Not applicable (not included in the filter)

Blank No answer

#### **Purpose**

This variable aims at identifying those persons who because of the health problem or difficulty they have, use/need personal assistance in order to help them to work.

#### **Definition**

'Personal assistance' refers to help from family members, relatives, friends, colleagues. Example: individuals, whose work is, inter alia, to assist persons with disability at the workplace, for example, a sign language interpreter, a job coach.

## NEEDADAP Col 209

### Short description

Because of the health problem or difficulty the person needs (not employed persons)/uses (employed persons) special equipment or needs (not employed persons)/has (employed persons) workplace adaptations to enable him/her to work

### Filter

Everybody aged 15-64 and (HEALTHMA = 1–17 or DIFFICMA = 1–10)

### Codes

1 Yes

2 No

9 Not applicable (not included in the filter)

Blank No answer

### Purpose

This variable aims at identifying those persons who because of the health problem or difficulty they have, need/use special equipment or need/have workplace adaptations in order to help them to work. The working conditions were/should be specifically modified to suit the needs of persons with long standing health conditions or diseases or with difficulties in performing basic activities.

### Definition

'Special equipment' includes a wide range of items, devices, pieces of equipment enabling the person to work. They are used to increase, maintain or improve functioning of individuals. The term 'workplace adaptations' refers to the architectural adaptations of the workplace.

Examples:

Technical Assistance (use of special equipment)

- Use of a screen reader
- Use of adapted telephone
- Use of adapted computer
- Use of a voice synthesiser
- Use of large print, braille

Adaptations to the workplace

- Adaptation of the entrance to the building
- Appropriate parking
- Ramps and handrails
- Accessible toilets
- Accessible lifts
- Modified workstation

## NEEDORGA Col 210

### Short description

Because of the health problem or difficulty the person needs (not employed persons)/has (employed persons) special working arrangements to enable him/her to work (such as, sedentary jobs, teleworking, flexible hours or less strenuous work)

### Filter

Everybody aged 15-64 and (HEALTHMA = 1–17 or DIFFICMA = 1–10)

### Codes

1 Yes

2 No

9 Not applicable (not included in the filter)

Blank No answer

### Purpose

This variable aims at identifying those persons who because of the health problem or difficulty they have, have/need special working arrangements in order to help them to work.

### Definition

'Special work arrangements' refer to all kinds of special arrangements and measures that can be thought of as supporting the work of persons with health conditions or difficulties in basic activities. They can be, for example:

- Arrangements in relation to the type of work: possibility to do lighter work, sedentary work, indoor work, etc.
- Respondent's time schedule has been adapted to his/her needs (less working hours, alternative ways of distribution of his/her working hours)
- The time schedule of his/her work colleagues has been modified in order to be adapted to respondent's needs.
- Teleworking (for instance someone with leg paralysis can work at home thanks to a special computer connection)

## LIMREAS Col 211-212

### Short description

Main reason for limitation in work (number of hours, type, getting to and from work) that is not caused by the longstanding health conditions/diseases or basic activity difficulties.

### Filter

Everybody aged 15-64



### Codes

- 01 Lack of qualifications/experience
- 02 Lack of appropriate job opportunities
- 03 Lack or poor transportation to and from workplace
- 04 Employers' lack of flexibility
- 05 Affects receipt of benefits
- 06 Family/caring responsibilities
- 07 Personal reasons
- 08 Other reason
- 09 No limitation in work
- 99 Not applicable (not included in the filter)
- Blank No answer

### Purpose

The reason why people are work limited is not just for health reasons but for many other external reasons as well. This variable is essential to see if there are environmental barriers associated with work limitations. The new concept of disability\* requests to have information about the whole population. Therefore, the aim of this variable is to identify the reason for which a person has a limitation in the work that they can do (excluding any longstanding health condition/disease or basic activity difficulty).

### Definition

Limitation in work includes limitation in any of the following: number of hours, type of work, getting to and from work.

### Implementation rules

The variable is asked to both employed and non-employed persons. In some cases the variable may appear 'hypothetical' and consequently difficult to answer. The interviewer should try as much as possible to get an answer (explaining eventually that it's about capacity to work and not performance). The interviewer should not put 'pressure' on the respondent to give a reply if this is too 'hypothetical' for him/her.

Cost of transportation should not be included in code 3 which is an accessibility related item. For this answer, code 08 "other reason" should be used.

\* For the purposes of the 2011 LFS module, disability is defined (based on the principles of the International Classification of Functioning, Disability and Health - ICF) as disadvantage experienced by an individual resulting from barriers to independent living or educational, employment or other opportunities that impact on people with impairments, ill health and /or functional limitations.

The types of barriers faced by disabled people include attitudes, for example, negative views of employers, policies, for example organisational rules which do not take disabled people into account; and physical factors, for example through the design of the work environment and transport systems.

Although the focus of disability is barriers and facilitators, the experiences of different people are also important. This is because the disabled population is very diverse and there is a need to understand which groups face barriers and disadvantage, why they face such barriers, and how improvements to benefits and services can be targeted.

## Specifications of the 2010 ad hoc module on Reconciliation between work and family life

Column	Code	Description	Filters/remarks
197	REGCARE	<i>Person regularly takes care of other children up to 14 (other than own/spouse's children living in the household) or of ill, disabled, elderly relatives/friends aged 15 or more in need of care</i> Yes, of other children up to 14 2 Yes, of relatives/friends aged 15 or more in need of care 3 Yes, of other children up to 14 and of relatives/friends aged 15 or more in need of care 4 No 9 Not applicable (not included in the filter) Blank No answer	Everybody aged 15 to 64
198	CHILDCAR	<i>Use of childcare services per week for the youngest child living in the household (including paid childminders, pre-school; apart from compulsory school)</i> <i>Childcare services are used for ... per week</i> 1 — up to 10 hours 2 — more than 10 hours and up to 20 hours 3 — more than 20 hours and up to 30 hours 4 — more than 30 hours and up to 40 hours 5 — more than 40 hours 6 — No use of childcare services 9 — Not applicable (not included in the filter) Blank No answer	Everybody aged 15 to 64 with at least one own/spouse's child up to 14 living in the household
199	IMPFACIL	<i>Impact of availability and affordability of care facilities on not working or working part-time</i> 1 Suitable care services for children are not available or affordable 2 Suitable care services for ill, disabled, elderly are not available or affordable 3 Suitable care services for both children and ill, disabled and elderly are not available or affordable. 4 Care facilities do not influence decision for labour market participation 9 Not applicable (not included in the filter) Blank No answer	Everybody aged 15 to 64 and (FTPTREAS ≠ 3 and SEEKREAS ≠ 3 and (REGCARE = 1-3 or has at least one own/spouse's child up to 14 living in the household)) and FTPT ≠ 1

Column	Code	Description	Filters/remarks
200	NOWRECHI	<i>Main reason (linked with childcare) for not working or working part-time</i>	Everybody aged 15 to 64 and (NEEDCARE = 1,3 or IMPFACIL = 1,3)
	1	No childcare services available	
	2	Available childcare services are too expensive	
	3	Available childcare services are not of sufficient quality	
	4	Other reasons linked with the lack of suitable childcare services	
	9	Not applicable (not included in the filter)	
	Blank	No answer	
201	NOWRECAR	<i>Main reason (linked with care of other dependants) for not working or working part-time</i>	Everybody aged 15 to 64 and (NEEDCARE = 2,3 or IMPFACIL = 2,3)
	1	No care services available	
	2	Available care services are too expensive	
	3	Available care services are not of sufficient quality	
	4	Other reasons linked with the lack of suitable care services	
	9	Not applicable (not included in the filter)	
	Blank	No answer	
202	VARHOURS	<i>Variable working hours</i>	Everybody aged 15 to 64 and STAPRO = 3
	1	Fixed start and end of a working day or varying working time as decided by the employer <i>Schedule decided by the employee within one of the following schemes:</i>	
	2	Flexitime/Working time banking	
	3	Daily number of hours fixed, but some flexibility within the day	
	4	Determines own work schedule (no formal boundaries at all)	
	5	Other	
	9	Not applicable (not included in the filter)	
	Blank	No answer	
203	POSSTEND	<i>Possible to vary start and/or end of working day for family reasons (at least one hour)</i>	VARHOURS = 1,3,5,blank
	1	Generally possible	
	2	Rarely possible	
	3	Not possible	
	9	Not applicable (not included in the filter)	
	Blank	No answer	
204	POSORGWT	<i>Possible to organise working time in order to take whole days off for family reasons (without using holidays)</i>	Everybody aged 15 to 64 and STAPRO = 3
	1	Generally possible	
	2	Rarely possible	
	3	Not possible	
	9	Not applicable (not included in the filter)	
	Blank	No answer	

Column	Code	Description	Filters/remarks
205	REDWORK 1 2 9 Blank	<i>Reduced working hours to take care of the youngest child in the household for at least one month (excluding maternity leave)</i> Yes No Not applicable (not included in the filter) No answer	Everybody aged 15 to 64 with at least one own/spouse's child up to the 8th birthday living in the household and (WSTATOR = 1,2 or (EXISTPR = 1 and REFYEAR-YEARPR <= age of the youngest child + 1))
206	STOPWORK 1 2 3 4 5 6 9 Blank	<i>Stopped working to take care of the youngest child in the household for at least one month (excluding maternity leave)</i> No <i>Yes, stopped working for a completed period of:</i> — up to 3 months — more than 3 months and up to 6 months — more than 6 months and up to 1 year — more than 1 year Has not returned to work yet Not applicable (not included in the filter) No answer	Everybody aged 15 to 64 with at least one own/spouse's child up to the 8th birthday living in the household and (WSTATOR = 1,2 or (EXISTPR = 1 and REFYEAR-YEARPR <= age of the youngest child + 1))
207	PARLEAVE 1 2 3 4 5 6 9 Blank	<i>Full-time parental leave of at least one month taken to care for the youngest child in the household (excluding maternity leave)</i> No, has not taken full-time parental leave for at least one month <i>Yes, has taken full-time parental leave for a completed period of:</i> — up to 3 months — more than 3 months and up to 6 months — more than 6 months and up to 1 year — more than 1 year Leave is still ongoing Not applicable (not included in the filter) No answer	Everybody aged 15 to 64 with at least one own/spouse's child up to the 8th birthday living in the household
210/215	0000 - 9999 00 - 99	<i>Weighting factor for the 2010 ad hoc module (optional)</i> Columns 210-213 contain whole numbers Columns 214-215 contain decimal places	Everybody aged 15 to 64

REGCARE (EREGCARE) Person regularly takes care of other children (<=14) or ill/disabled/elderly relatives/friends (>=15) in need of care (Eurostat AHM 2010 Col 197)

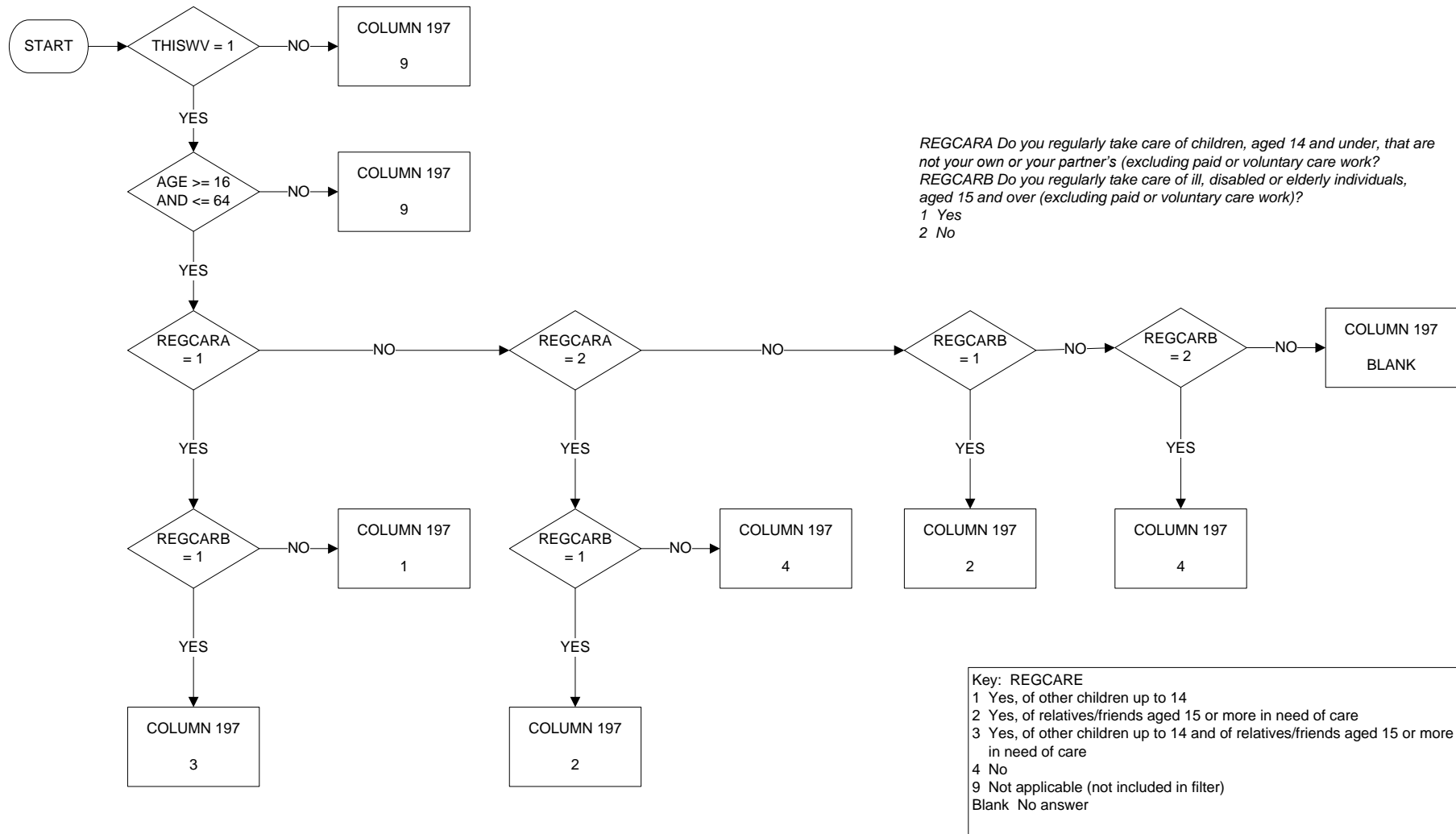

CHILDCAR (ECHILDSV) Use of childcare services per week for the youngest child living in the household  
(Eurostat AHM 2010 Col 198)

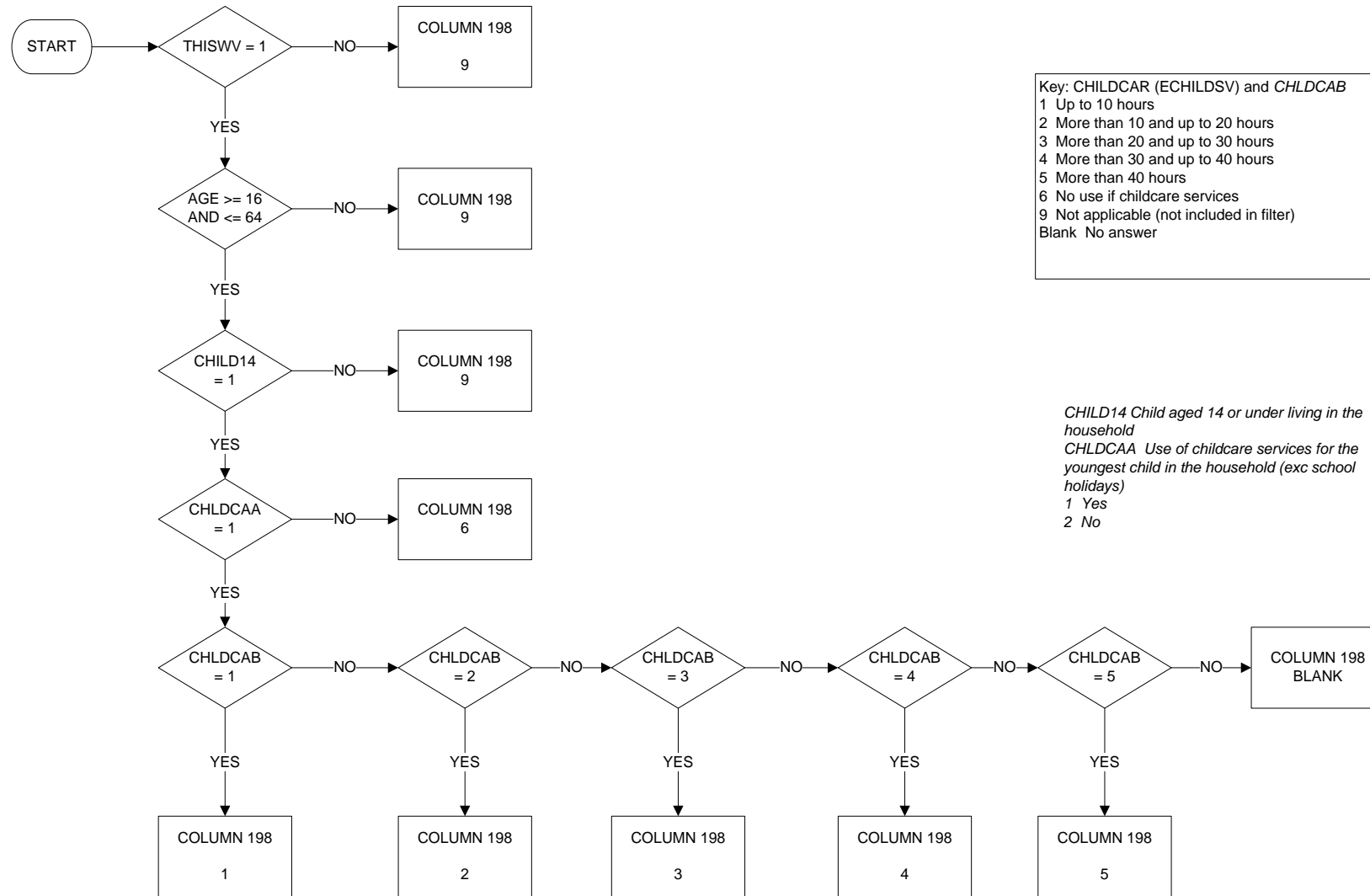

Key: CHILDCAR (ECHILDSV) and CHLDCAB  
 1 Up to 10 hours  
 2 More than 10 and up to 20 hours  
 3 More than 20 and up to 30 hours  
 4 More than 30 and up to 40 hours  
 5 More than 40 hours  
 6 No use if childcare services  
 9 Not applicable (not included in filter)  
 Blank No answer

CHILD14 Child aged 14 or under living in the household  
 CHLDCAA Use of childcare services for the youngest child in the household (exc school holidays)  
 1 Yes  
 2 No

IMPFACIL (EIMPFACIL) Impact of availability and affordability of care facilities on not working or working part-time  
(Eurostat AHM 2010 Col 199)

Start date: Jan 2010  
End date: Dec 2010

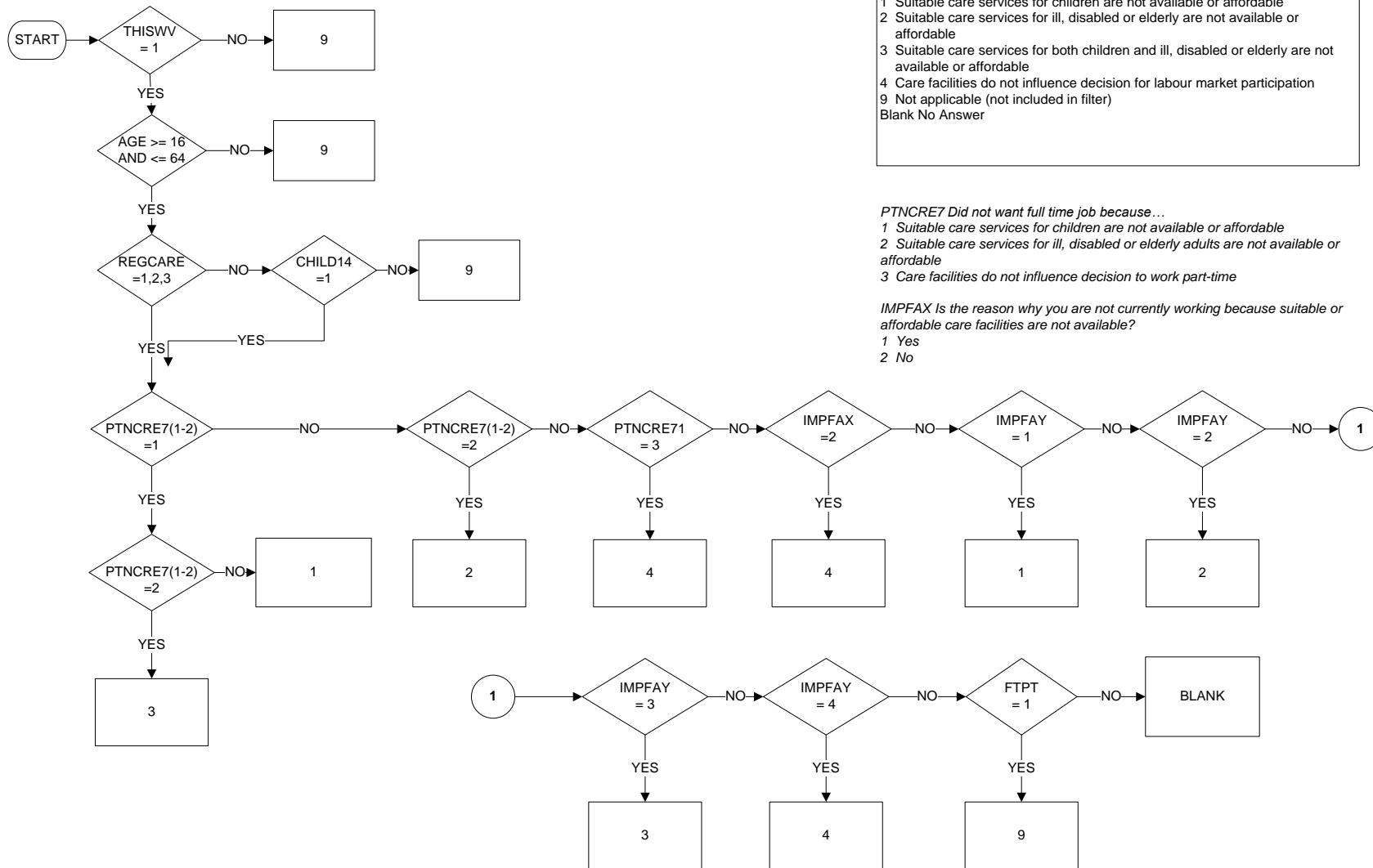

Key: IMPFACIL (EIMPFACIL) and IMPFAY  
 1 Suitable care services for children are not available or affordable  
 2 Suitable care services for ill, disabled or elderly are not available or affordable  
 3 Suitable care services for both children and ill, disabled or elderly are not available or affordable  
 4 Care facilities do not influence decision for labour market participation  
 9 Not applicable (not included in filter)  
 Blank No Answer

PTNCRE7 Did not want full time job because...  
 1 Suitable care services for children are not available or affordable  
 2 Suitable care services for ill, disabled or elderly adults are not available or affordable  
 3 Care facilities do not influence decision to work part-time

IMPFAF Is the reason why you are not currently working because suitable or affordable care facilities are not available?  
 1 Yes  
 2 No

NOWRECHI (ERECHIPT) Main reason (linked with childcare) not working or working part-time  
(Eurostat AHM 2010 Col 200)

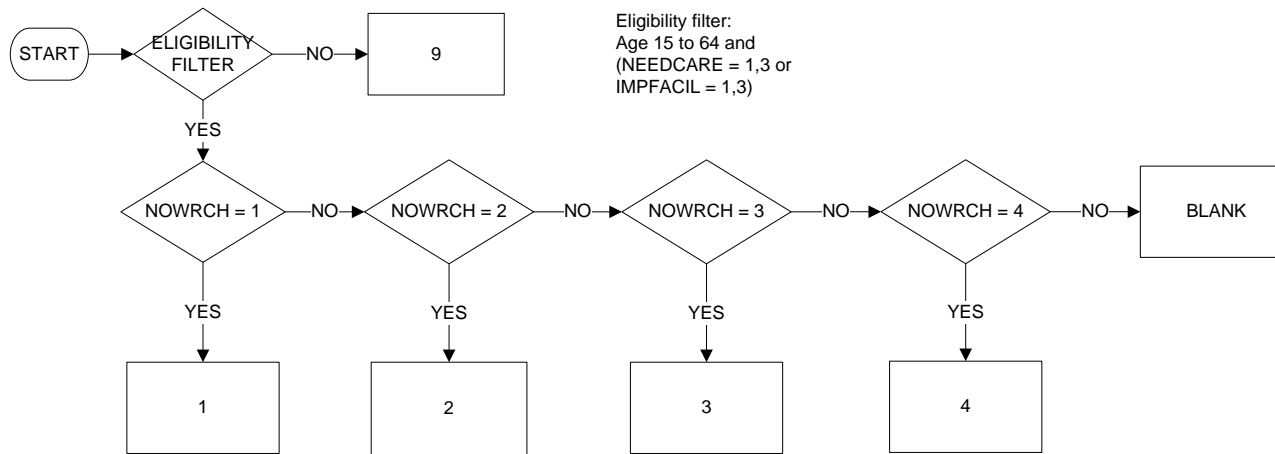

Eligibility filter:  
Age 15 to 64 and  
(NEEDCARE = 1,3 or  
IMPFACIL = 1,3)

Key: NOWRECHI (ERECHIPT) and NOWRCH  
 1 No childcare services available  
 2 Available childcare services are too expensive  
 3 Available childcare services are not of sufficient quality  
 4 Other reasons linked with lack of suitable childcare services  
 9 Not applicable (not included in filter)  
 Blank No Answer



NOWRECAR (ERECARPT) Main reason (linked with care of other dependents) for not working or working part-time  
(Eurostat AHM 2010 Col 201)

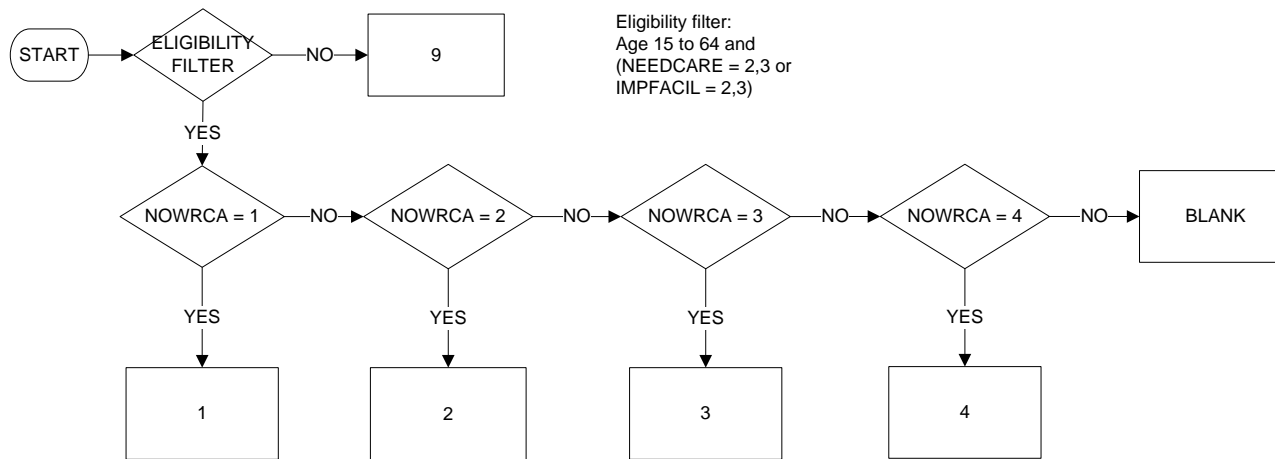

Eligibility filter:  
Age 15 to 64 and  
(NEEDCARE = 2,3 or  
IMPFACIL = 2,3)

Key: NOWRECAR (ERECARPT) and NOWRCA  
 1 No care services available  
 2 Available care services are too expensive  
 3 Available care services are not of sufficient quality  
 4 Other reasons linked with lack of suitable care services  
 9 Not applicable (not included in filter)  
 Blank No Answer

VARHOURS (EVARHOUR) Main reason (linked with care of other dependents) for not working or working part-time  
(Eurostat AHM 2010 Col 202)

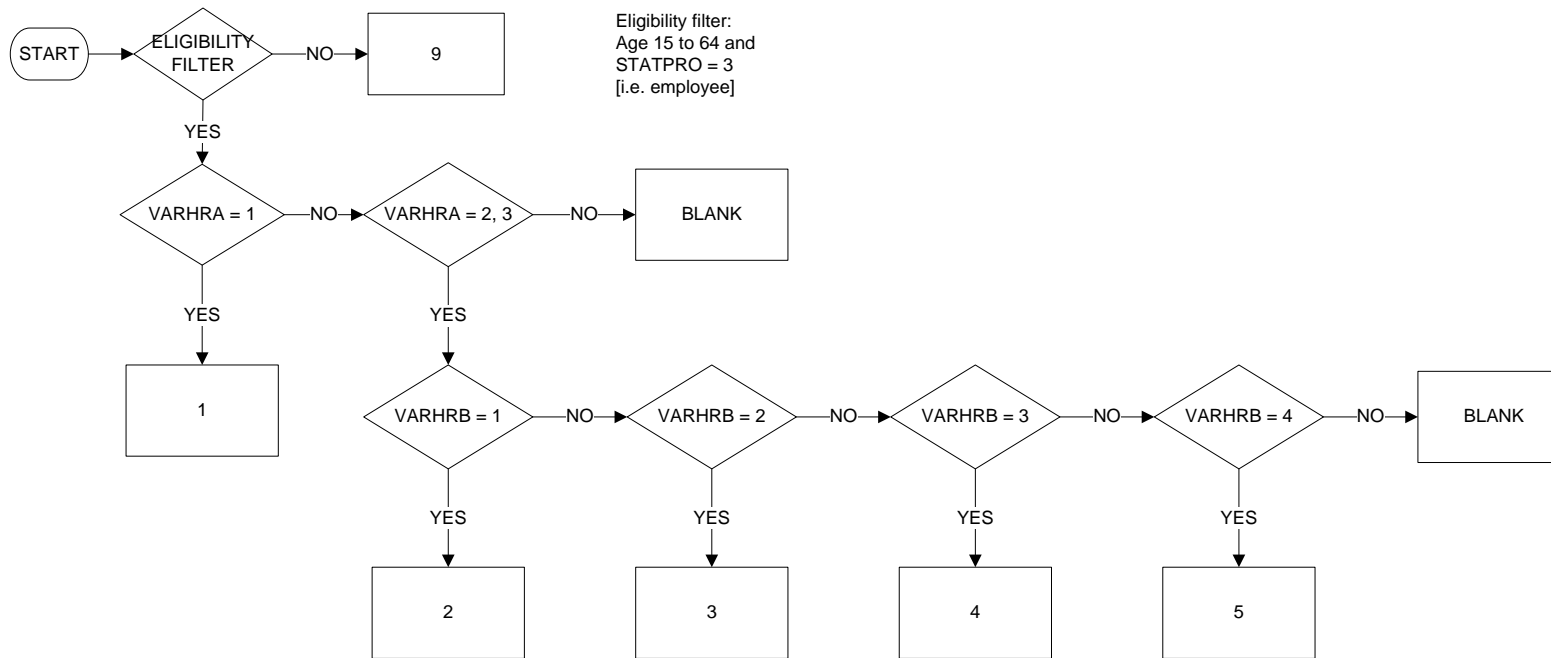

Eligibility filter:  
Age 15 to 64 and  
STATPRO = 3  
[i.e. employee]

Key: VARHOURS (EVARHOUR)  
 1 Fixed start and end of working day or varying working times as decided by employer  
*Schedule decided by employee within one of the following schemes:*  
 2 Flexitime/Working time banking  
 3 Daily number of hours fixed but some flexibility within the day  
 4 Determines own work schedule (no formal boundaries at all)  
 5 Other  
 9 Not applicable (not included in filter)  
 Blank No Answer

POSSTEND (EPOSTEND) Possible to vary start and/or end of working day for family reasons (at least one hour)  
(Eurostat AHM 2010 Col 203)

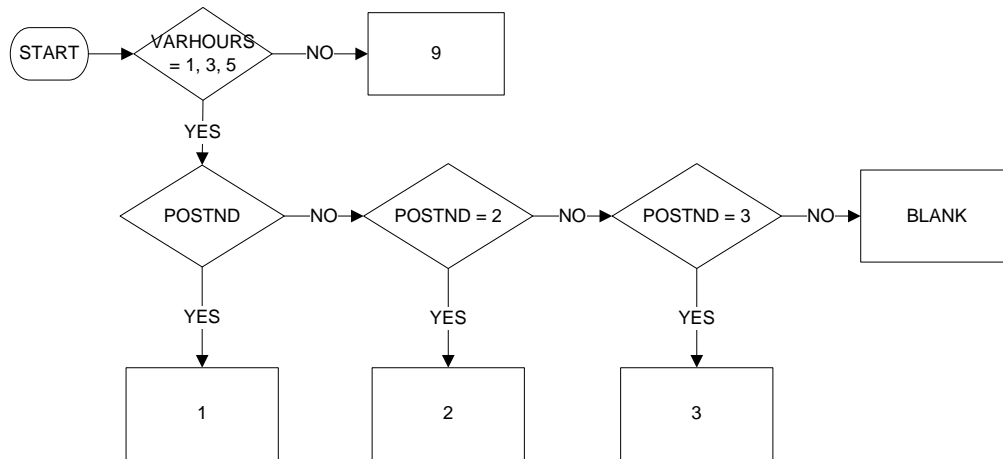

Key: POSSTEND (EPOSTEND)  
 1 Generally possible  
 2 Rarely possible  
 3 Not possible  
 9 Not applicable (not included in filter)  
 Blank No Answer

POSORGWT (EPOSGWT) Possible to organise working time in order to take whole days off for family reasons (without using holidays) (Eurostat AHM 2010 Col 204)

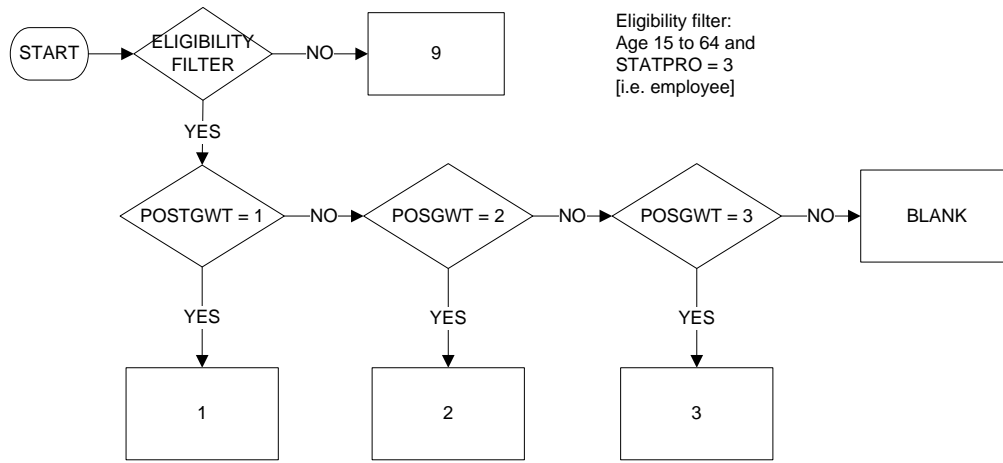

Key: POSORGWT (EPOSGWT)  
1 Generally possible  
2 Rarely possible  
3 Not possible  
9 Not applicable (not included in filter)  
Blank No Answer

REDWORK (EREDWORK) Reduced working hours to take care of the youngest child in the household for at least one month (excluding maternity leave) (Eurostat AHM 2010 Col 205)

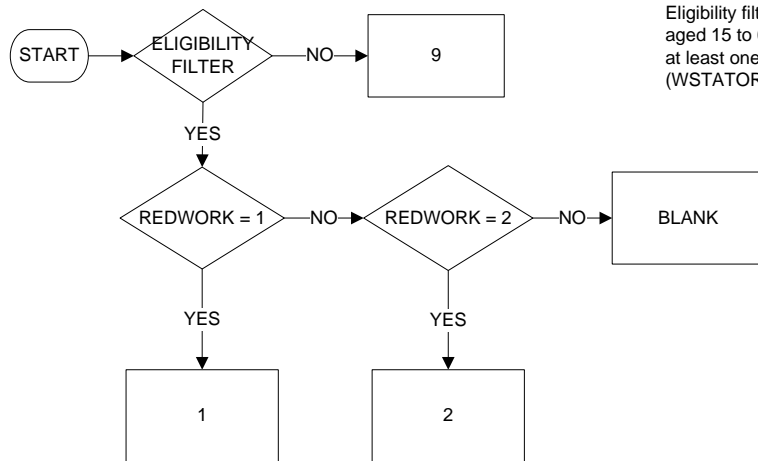

Eligibility filter:  
aged 15 to 64 with  
at least one own/spouse's child up to the 8th birthday living in the household and  
(WSTATOR = 1,2 or (EXISTPR = 1 and REFYEAR-YEARPR <= age of the youngest child + 1))

Key: REDWORK (EREDWORK)  
1 Yes  
2 No  
9 Not applicable (not included in filter)  
Blank No Answer

**STOPWORK (ESTOPWRK) Stopped working to take care of the youngest child in the household for at least one month (excluding maternity leave) (Eurostat AHM 2010 Col 206)**

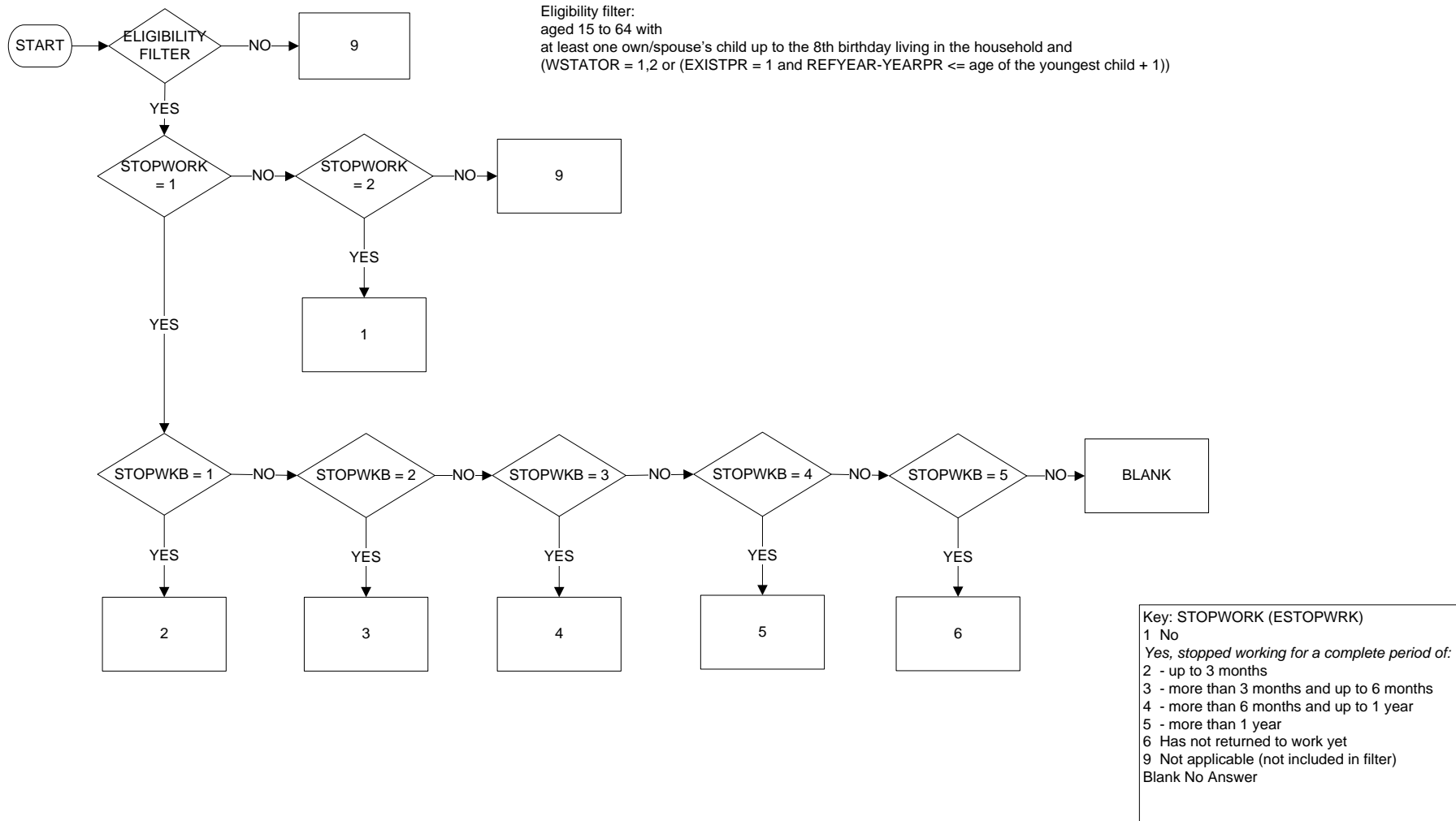

PARLEAVE (EPARLEAV) Full-time parental leave of at least one month taken to care for the youngest child in the household (excluding maternity leave)(Eurostat AHM 2010 Col 207)

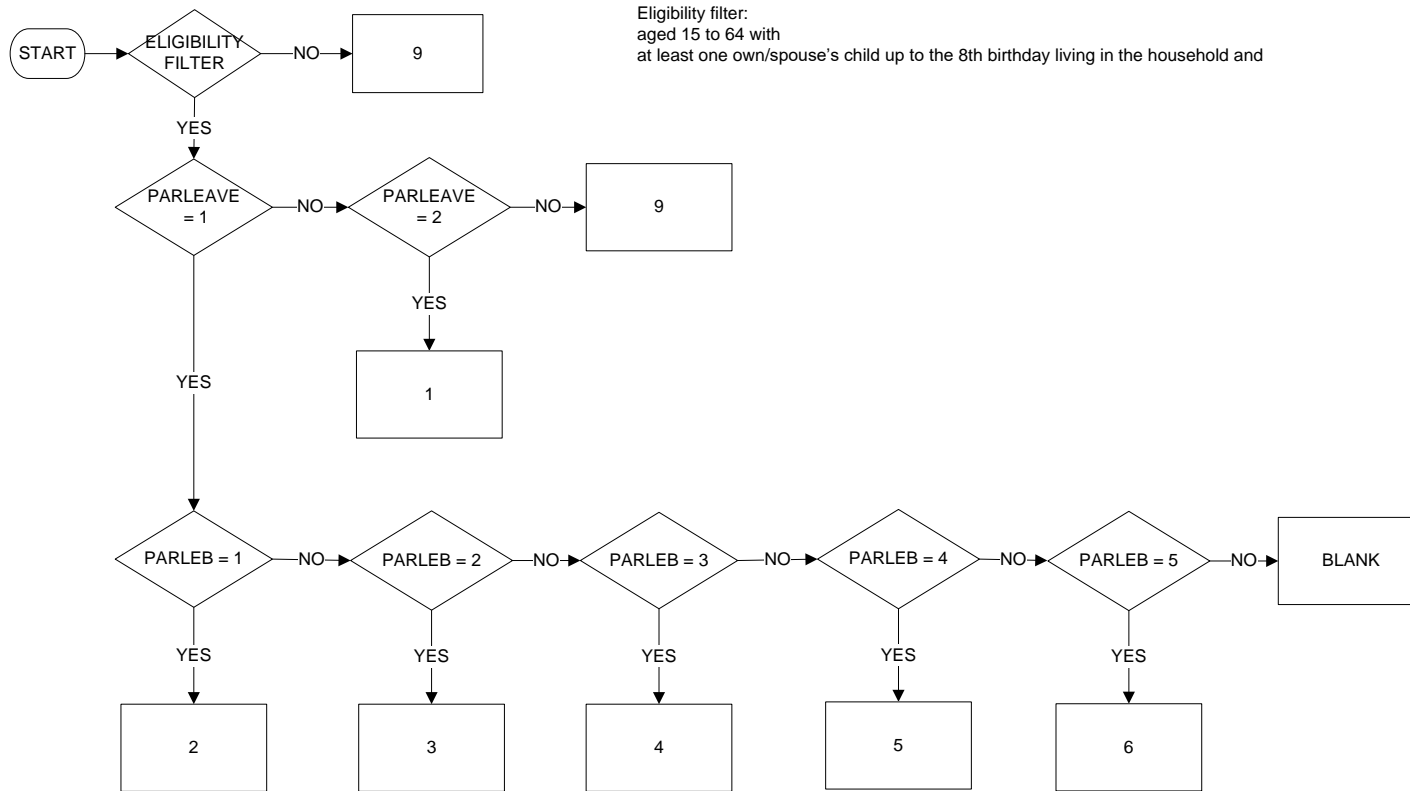

Eligibility filter:  
aged 15 to 64 with  
at least one own/spouse's child up to the 8th birthday living in the household and

Key: PARLEAVE (EPARLEAV)  
 1 No, has not taken full-time parental leave for at least one month  
 Yes, has taken full-time parental leave for a complete period of:  
 2 - up to 3 months  
 3 - more than 3 months and up to 6 months  
 4 - more than 6 months and up to 1 year  
 5 - more than 1 year  
 6 Leave is still ongoing  
 9 Not applicable (not included in filter)  
 Blank No Answer

## Explanatory Notes for LFS 2010 ad hoc module

### REGCARE Col 197

#### Description

Person regularly takes care of other children up to 14 (other than own spouse's children living in the household) or of ill, disabled, elderly relatives/friends aged 15 or more in need of care.

The aim of REGCARE is to identify all care responsibilities undertaken by the person interviewed since all care responsibilities are susceptible to pose an obstacle for the labour market participation of the person. As it is generally assumed that parents with children up to 14 years (living in the household) have care responsibilities for those children, REGCARE addresses regular care for other children up to 14 and for relatives/friends aged 15 or more in need of care only. Care provided as professional care minder, as voluntary work or pure financial support are excluded.

#### Definition

“Caring”, “care”, and “carer”: the variable focuses on the carers and not on the persons who are cared for (employment perspective linked with care responsibilities). Carers are defined as people who look after or provide help to children or to friends/relatives in need of care because they are sick/elderly/incapacitated/disabled (help, assistance, support, surveillance).

Examples of caring tasks for other children up to 14: personal care, homework, playing games, reading, taking out, and surveillance.

Examples of caring tasks for friends/relatives in need of care aged 15 or more: personal care (e.g. dressing, washing), physical help (e.g. walking), helping with paperwork or financial matters, domestic help (e.g. housework, laundry) and company.

“Regularly” is defined as on a fixed pattern (every day, every week ...) and frequently (not only occasionally, for instance not only once in 3 months). The reference period is the current situation.

“Other children” correspond to other than own/spouse's children living in the household that is to say to:

- own/spouse's children living outside the household
- other children (not own/spouse's) living inside or outside the household.

#### Implementation rules

- For own/spouse's children living in the household see the general remark above.
- Adopted children should be considered as own children, foster children as other children.
- Children aged 14 years old should be considered.
- Care for children aged 15 or more who are not ill/disabled is out of the scope of this variable.
- The adults taken care of can live inside or outside the household.
- If the care consists only of financial support or if the care is a volunteer work for a charity or for another organisation, then it should not be considered for this variable.
- Care as a job should be excluded (this means that care done in a professional capacity is excluded). Persons who provide care as a job, even if it is only a few hours per week, should be coded “No” unless they care for people in their spare time as well.
- Persons who receive allowances to take care of disabled relatives should be considered as carers (codes 2 or 3).



- Children up to 14 who have a handicap, a disability or a health problem are considered as “children” (code 1, or 3 if also care of dependant adults takes place).

Note: Disabled persons who are obviously not able to take regularly care of others need not to be asked as this could be annoying for them. The respective coding '4' could be assigned automatically.

## **CHILDCAR Col 198**

### **Description**

Use of childcare services per week for the youngest child living in the household (including paid childminders, pre-school; apart from compulsory school).

The variable addresses the standard situation outside holidays or other particular arrangements (e.g. emergency arrangements due to sick child or other problems).

- If the youngest child is a school-going child only services outside compulsory school hours are to be considered.
- Children aged 14 years old should be considered.
- Codes 1 to 5: Average total number of hours per week for all childcare services used during a typical week (omitting school holidays or emergency arrangements).
- Code 6: Generally, no childcare services are used. This includes situations where partners/relatives/neighbours/friends (unpaid) care for the child OR if children up to 14 always take care of themselves/each other OR if the person works at home/cares for the child at the work place OR if no childcare is used at all (e.g. compulsory school hours correspond to working hours).

Note: if a child (sister/brother) aged more than 14 takes care of the children up to 14, then no childcare services are used and the coding should be 6.

Note: for consistency reasons at household level father and mother should give the same answer. In a situation where both father and mother are available for a direct interview, it might be recommendable to ask only one of the two persons and to fill the variable CHILDCAR for the other person with the information already collected.

Note: countries should decide at national level on the use of different formulations for families with at least one younger and families with only older children, where the latter might not need normal childcare any more.

## **IMPFACIL Col 199**

### **Description**

Impact of availability and affordability of care facilities on not working or working part-time.

This variable extends the coverage of the core-variable NEEDCARE in the context of this module to further groups and is therefore defined in the same way as NEEDCARE.

The intention of IMPFACIL and NEEDCARE is the identification of (negative) impacts of missing suitable care facilities on the labour market participation. If it is considered to be more appropriate for the national implementation to add a positive code, for instance for respondents who decide to work

part-time because of the availability of childcare, this is of course possible. For the transmission to Eurostat these answers should be coded as '4' – Care facilities do not influence decision for labour market participation. Positive codes of this kind might be added to NEEDCARE in the future after a review of the variable in the light of the 2010 ad hoc module results.

## **NOWRECHI Col 200**

Main reason (linked with childcare) for not working or working part-time.

- Code 1: this code should be used when the care is not available as needed. This means that there is no childcare service for the children in the area (accessible) at all (including: available services are too far away) OR no childcare service available (no place available / full ...) OR not enough care service for children who need more time of care (e.g. a child is cared for in the morning but lack of care services in the afternoon) OR the opening hours are in general not convenient. This code should therefore also be used if childcare services are available at normal times, e.g. approximately from 7h00 to 19h00, but the care would be needed at special times, that is to say approximately before 7h00 in the morning, at night, after 19h00 in the evening, during the weekend or during school holidays.
- Code 2: a person who is not working and who might expect a salary which is not high enough compared to the cost of the care should be coded here (the salary can be higher than the cost of the care but not high enough to encourage the person to work).
- Code 3: “quality not sufficient” from the person’s point of view includes educational contents not sufficient, too many children and not enough carers, person not confident (does not trust), ... Should also be used in case of lack of suitable childcare services for children (up to 14) with special needs.
- Code 4: This is a residual category and it applies only when the conditions in the cases 1 – 3 do not apply.

## **NOWRECAR Col 201**

Main reason (linked with care of other dependants) for not working or working part-time.

- Code 1: this code should be used when the care is not available as needed. This means that there is no care service for the person at all (including: available services are too far away) OR no care service available (no place available / full ...) OR not enough care (need of a prolongation of the care service) OR the opening hours are in general not convenient. This code should therefore also be used if care services are available at normal times, e.g. approximately from 7h00 to 19h00, but the care would be needed at special times, that is to say approximately before 7h00 in the morning, at night, after 19h00 in the evening, during the weekend, during holidays, 24 hours/24 hours.
- Code 2: too expensive for the person helped OR for the person who helps. A person who could expect a salary which is not high enough compared to the cost of the care he/she would have to support should be coded here (the salary can be higher than the cost of the care but not high enough to encourage the person to work).
- Code 3: “quality not sufficient” from the interviewed person’s point of view OR from the helped person’s point of view. Includes persons not confident (do not trust).
- Code 4: This is a residual category and it applies only when the conditions in the cases 1 – 3 do not apply.

## VARHOURS Col 202

Variable working hours.

- Code 1: Fixed start and end are defined as a regular (not necessarily constant) long-term pattern of fixed daily working times without the possibility to start or end the working day later/earlier. All schemes which allow the employer but not the employee to vary the working hours should be coded 1 as well. In particular, shift work should be coded 1, even if the employee can change shifts, as the varying pattern is basically defined by the employer and not the employee. The same applies to annualised hours contracts.
- Code 2: Flexitime / working time banking is a system of accumulation and settlement of debit and credit hours around a standard number of weekly or monthly working hours. Over a longer period, the average number of working hours is equal to the number of contractually agreed working hours. Working time banking as an arrangement of total autonomy when to start and finish work.
- Code 3: This code covers the concept of staggered working hours, a situation where workers may start earlier and finish later outside a range of hours according to regulation or collective agreement when presence is compulsory. Contrary to flexitime / working time banking there are no account systems of credit and debit hours allowing employees to take time off. The number of hours worked each day is equal to the contractual number. Staggered working allows the normal working hours to be varied to suit an individual's needs (as long as service needs/requirements are assured), whilst working the daily contracted hours for the post. Banded start/end, for instance working from 10am-6pm rather than 9am-5pm, is one special example of staggered working hours. This code also includes cases where the daily working hours can be considered as fixed, but in practice some flexibility regarding the daily working hours is given, and it is not controlled whether a person works exactly the daily number of hours. One example of this is work done mainly during office hours because at that time clients have to be served, but outside these hours some flexibility is given.
- Code 4: This code should be used if the employee can define his own work schedule without any formal boundaries.
- Code 5: This is a residual category and it applies only when the patterns described in codes 1 - 4 do not apply. One example is the frequent case of a fixed start of the day with a variable end, i.e. a worker has to work until the work is finished (no other category precisely matches this case). Another example is teachers for whom the teaching hours are defined, whereas the preparation and follow-up working hours can be organised by the teachers themselves. Other individual agreements which do not fit into one of the other categories should also be coded here.

Note: the order of codes reflects the expected frequency of occurrence. The order of increasing flexibility is 1, 3, 2 and 4. The coding should always reflect the maximum flexibility given, e.g. respondents with staggered working hours combined with a system of credit and debit hours should be coded as 2. Countries are of course free to use the order of flexibility in the questionnaires to highlight this.

Note: National Statistical Institutes should adapt the concepts described above further to the national situation if they consider this as necessary to get good results. They should in particular find descriptions of the different types of varying working time arrangements which are easily understandable for the respondents in their country. If certain arrangements listed do not exist in a country, this should be taken into account when designing the questionnaire in order not to confuse respondents.

Note: even if self-employed might face similar problems as employed, it would be too difficult to cover them. Many self-employed might also be annoyed or puzzled by questions on variable working hours.

### **POSTEND Col 203**

Possible to vary start and/or end of working day for family reasons (at least one hour).

- Code 1: the person can generally start later and/or finish earlier for family reasons (outside particular periods of urgent work ...).
- Code 2: the person can start later and/or finish earlier for family reasons, but rarely and not generally. This covers cases of emergencies.
- Code 3: the person can not start later and/or finish earlier for family reasons. Respondents for whom this question is not relevant because of their special workplace, e.g. oil-platform workers, should also be coded here.

### **POSSRGWT Col 204**

Possible to organise working time in order to take whole days off for family reasons (without using holidays).

- Code 1: the person can generally organise the working time in order to take whole days off for family reasons (outside particular periods of urgent work ...; even if a limit for the number of days exists). Persons who have the general possibility to organise their working time in order to take whole days off should be coded 1 because they can do it in particular for family reasons.
- Code 2: the person can organise the working time in order to take whole days off for family reasons, but rarely and not generally. This covers cases of emergencies.
- Code 3: this code applies to persons who can not organise the working time in order to take whole days off, e.g. teachers.

### **REDWORK Col 205**

Reduced working hours to take care of the youngest child in the household for at least one month (excluding maternity and paternity leave).

- Code 1: All forms of reduction of working hours on a daily or weekly basis are covered (for instance, persons taking every Monday off during two months using a parental leave). Standard holidays or flexitime systems (balance of overtime) are excluded if these are the only arrangements used. The reduction should however be relatively significant and regular, i.e. occur for at least one month (exceptional cases do not need to be surveyed). Arrangements of less than one month duration are not included. Special cases such as separated parents who alternately spend one week with their child (reducing working hours or not working at all) and work e.g. full-time the next week (when the separated partner cares for the child) should also be coded here in case this corresponds to a reduction of working hours as defined above.

The long reference period (child up to the 8th birthday living in the household) allows covering parental leave rights: replies are therefore not only expected from persons currently working, but also from persons unemployed or inactive who worked in the past. In case of multiple jobs, the reduction concerns any or all jobs (reduction of working hours in the main or second job only, total interruption of the second job and same patterns for the main job, etc.).

- Code 2: this code should also include the following cases:
  - o Persons on maternity or paternity leave,
  - o Persons having reduced their working time only using standard holidays or flexitime systems (balance of overtime).

- Note: reductions of working time caused by temporary care absence should be included if they can be considered as regular reduction as defined above. It is not relevant whether the care absence is paid or unpaid. The only arrangements which are definitely excluded in REDWORK are those based entirely on standard holidays and flexitime compensation.

## **STOPWORK Col 206**

Stopped working to take care of the youngest child in the household for at least one month (excluding maternity and paternity leave).

One month can also be defined as 4 consecutive weeks.

Persons who left their job (with or without fixed duration) and who stopped working or looking for a job in order to look after the youngest child are included.

## **PARLEAVE Col 207**

Full-time parental leave of at least one month taken to care for the youngest child in the household (excluding maternity and paternity leave).

The focus of PARLEAVE is on full-time parental leave for the youngest child. It might be combined with the variable STOPWORK for persons who are working or who worked after or shortly before the birth of the youngest child (cp the respective filter), but as parental leave entitlements are not in all Member States linked to employment, the filter of PARLEAVE is not restricted to these groups. However, the filter used during the interviews might be restricted to those employed or not employed with work experience (as in STOPWORK) if parental leave is strictly related to employment in a given country. For countries in which parental leave is not restricted to employment a similar approach is recommended: a split into two questions, namely one targeting the same group as STOPWORK and another one for the remainder of the persons to cover all other cases.

- Code 1: this code applies in particular to persons who never took any parental leave or who took only part-time parental leave. It should also include the following cases:
  - Persons who never worked (in countries in which parental leave entitlements are linked to employment),
  - Persons on maternity or paternity leave,
  - Persons having interrupted their work entirely with standard holidays or flexitime systems (balance of overtime).
- Codes 2 to 6: the duration of the full-time parental leave should be relatively significant, i.e. at least one month in a block. Interruptions of less than one month, standard holidays or flexitime systems (balance of overtime) are excluded if these are the only arrangements used. However, the codes 2 to 6 would cover persons who took at least one month, combining fulltime parental leave with other arrangements, e.g. standard holidays or flexitime systems (balance of overtime), as it might be difficult for the respondent to distinguish all different concepts and periods exactly.

In case several parental leave periods of more than one month exist, in general the length of the longest period should be provided in line with the provisions for STOPWORK. However, the total duration of all periods of this kind can be provided if this gives a clearer picture of the situation of the respondent (cp. STOPWORK above). The parental leave take-up rate is not affected by this approach, and the results should be better comparable with STOPWORK as the same criteria are applied. In case of multiple jobs, the parental leave might concern one job only. The exact duration of the parental

leave is not asked from persons who are still on full-time parental leave, as they might not know the date of its termination yet.

**Specifications of the 2009 ad hoc module on the entry of young people into the labour market**

Column	Code	Description	Filter
203 PARHAT	1 2 3 9 Blank	<b>Highest level of education successfully completed by father or mother</b> Low: ISCED 0, 1, 2 and 3c short Medium: ISCED 3-4 (without 3c short) High: ISCED 5-6 Not applicable (persons aged less than 15 or more than 34) No answer	Everybody aged 15-34
204-207 PARFOR	.... 9999 Blank	<b>Country of birth of father and mother</b> (For Germany: nationality/former nationality of father and mother when they have in the reference week the German nationality) For coding, see ISO country classification 4 digits (father - 2 first digits, mother - 2 last digits) Not applicable No answer	Everybody aged 15-34
208 HATVOC	1 2 3 4 5 9 Blank	<b>Orientation of the highest level of formal education attained (HATLEVEL)</b> General education Vocational education mainly (or solely) school based Combination of school and work place based vocational education Vocational education mainly work place based Vocational education, with no distinction possible between 2, 3 and 4 Not applicable No answer	Everybody aged 15-34 and HATLEVEL=21-43
209-214 STOPDATE	MMYYYY 999999 Blank	<b>Month and year of leaving formal education for the last time</b> Month and year Not applicable No answer	Everybody aged 15-34 and EDUCSTAT=2 and HATLEVEL≠00
215 WORKEDUC	0 1 2 3 4 5 6 7 9 Blank	<b>Work during studies in formal education</b> No work or work less than 1 month per year Work (only) as part of educational programme Work while studying but outside educational programmes Work (only) during an interruption of studies Work as combination of 1 and 2 Work as combination of 1 and 3 Work as combination of 2 and 3 Work as combination of 1, 2 and 3 Not applicable No answer	Everybody aged 15-34
216-221 JOBSTART	000000 000001 MMYYYY 999999 Blank	<b>Month and year of start of the first job of more than 3 months after leaving formal education for the last time</b> Never had a job of more than 3 months Current job is my first job Month and year Not applicable No answer	Col.209-214 ≠ 999999 and blank
222-224 JOB DUR	... 999 Blank	<b>Duration of the first job of more than 3 months (after leaving formal education for the last time)</b> Number of months Not applicable No answer	Col. 216-221 ≠ 000000 and 000001 and 999999
225 FINDMETH	1 2	<b>Method which allowed to find the first job of more than 3 months (after leaving formal education for the last time)</b> Via educational institution Via PES (Public Employment Services)	Col. 216-221 ≠ 000000 and 999999

## Labour Force Survey – United Kingdom

Column	Code	Description	Filter
	3 4 5 6 7 8 9 Blank	Via ads in press or on the Internet Submission of direct (spontaneous) job application to employer Via family and friends Job found after previous experience (summer/student job, apprenticeship, traineeship, voluntary job) in the same company Launching private business Other Not applicable No answer	
226-229 JOBBOCC	.... 9999 Blank	<b>Occupation of the first job of more than 3 months (after leaving formal education for the last time)</b> ISCO-88 (COM) coded at 3 or if possible 4 digits level Not applicable No answer	Col. 216-221 ≠ 000000 and 000001 and 999999
230 JOBCONTR	1 2 3 4 5 6 9 Blank	<b>Type of contract of the first job of more than 3 months (after leaving formal education for the last time)</b> Self-employed Employee, permanent full-time Employee, permanent part-time Employee, temporary full-time Employee, temporary part-time Family worker Not applicable No answer	Col. 216-221 ≠ 000000 and 000001 and 999999
231 TRANSACT	1 2 3 4 5 6 7 8 9 Blank	<b>Main activity after leaving formal education for the last time and before starting the first job of a duration of at least 3 months</b> Employed - work in job(s) of short duration (maximum 3 months) Compulsory military or community service Not employed, actively looking for the job Not employed, not looking actively for a job because of: Family responsibilities Participation in non-formal education Voluntary activities Health problems Other reasons Not applicable No answer	Col.209-214 ≠ 999999 and blank and {first job started more than 3 months after the date in Col.209-214 or Col.216-221 =000000}
232/237	0000-9999 00-99	<b>Weighting factor for the LFS module 2009 (optional)</b> Columns 232-235 contain whole numbers Columns 236-237 contain decimal places	Everybody aged 15-34
238 (PARFOR)	9999 Blank	<b>Nationality at birth of parents (optional)</b> For coding, see ISO country classification Not applicable No answer	Everybody aged 15-34



PARHAT (EHEDPAR): Highest level of education successfully completed by father or mother  
Eurostat AHM 2009 Column 203

Page 1 of 1  
Start date: Jan 2009  
End date: Dec 2009

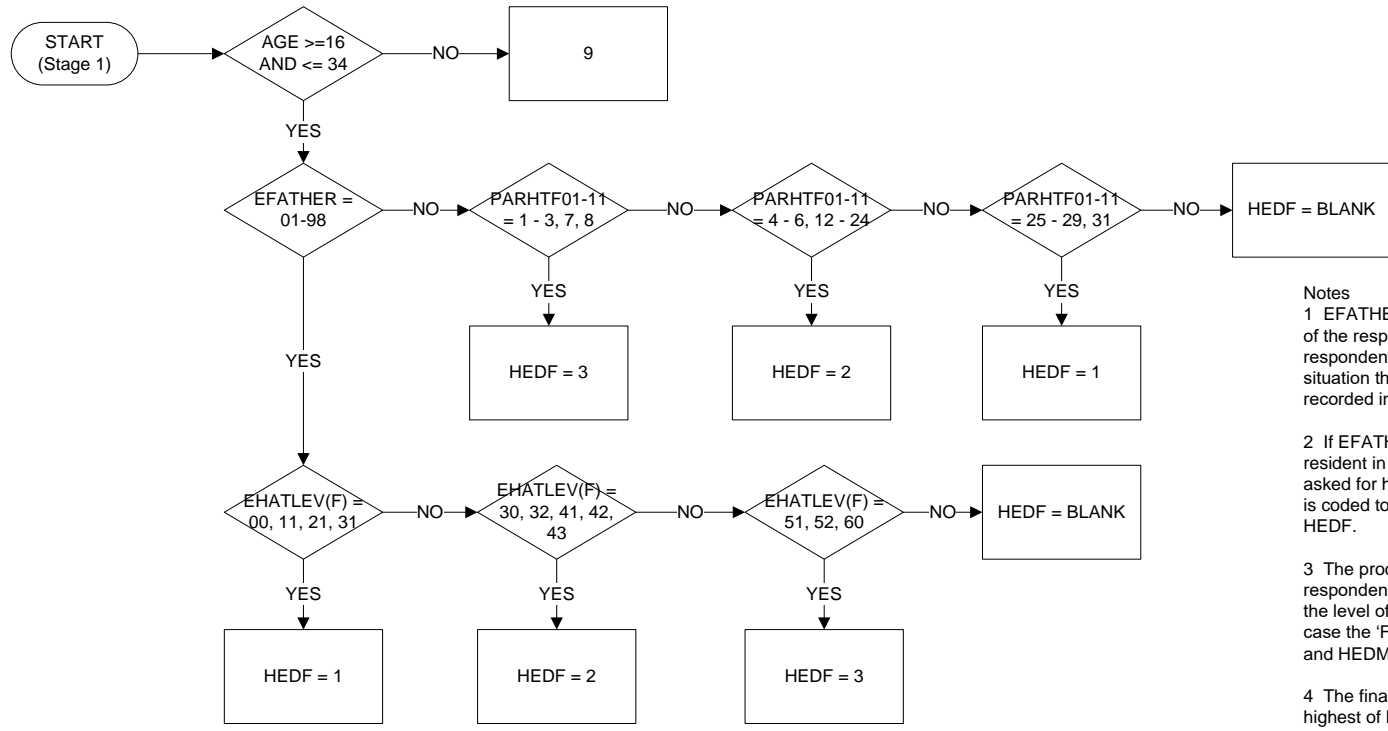

Notes  
1 EFATHER indicates the sequence number in the household of the respondent's father. If in the range 01-98 then the respondent's father is a member of the household. In this situation the father's level of education is taken from the data recorded in the father's own interview (EHATLEV).

2 If EFATHER is 99 then the respondent's father is not resident in the household. In this situation the respondent is asked for his/her father's level of education (PARHTF) and this is coded to one of three levels in the temporary variable HEDF.

3 The process described in the Stage 1 relates to the respondent's father; the same process is repeated to establish the level of education of the respondent's mother. In which case the 'F' suffix is replaced by an 'M' suffix, e.g. PARHTM and HEDM.

4 The final value for PARHAT is established by selecting the highest of HEDF and HEDM in Stage 2.

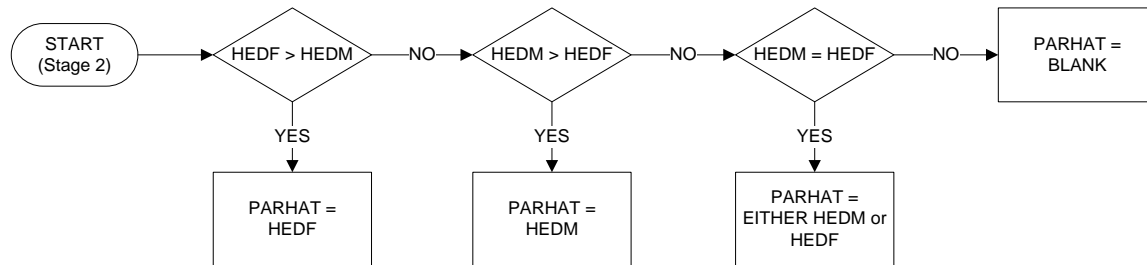

Key	
1 Low:	ISCED 0, 1, 2 and 3c short
2 Medium:	ISCED 3-4 (ex 3c short)
3 High:	ISCED 5-6

PARFOR Country of birth of father and mother  
Eurostat AHM 2009 Columns 204-207

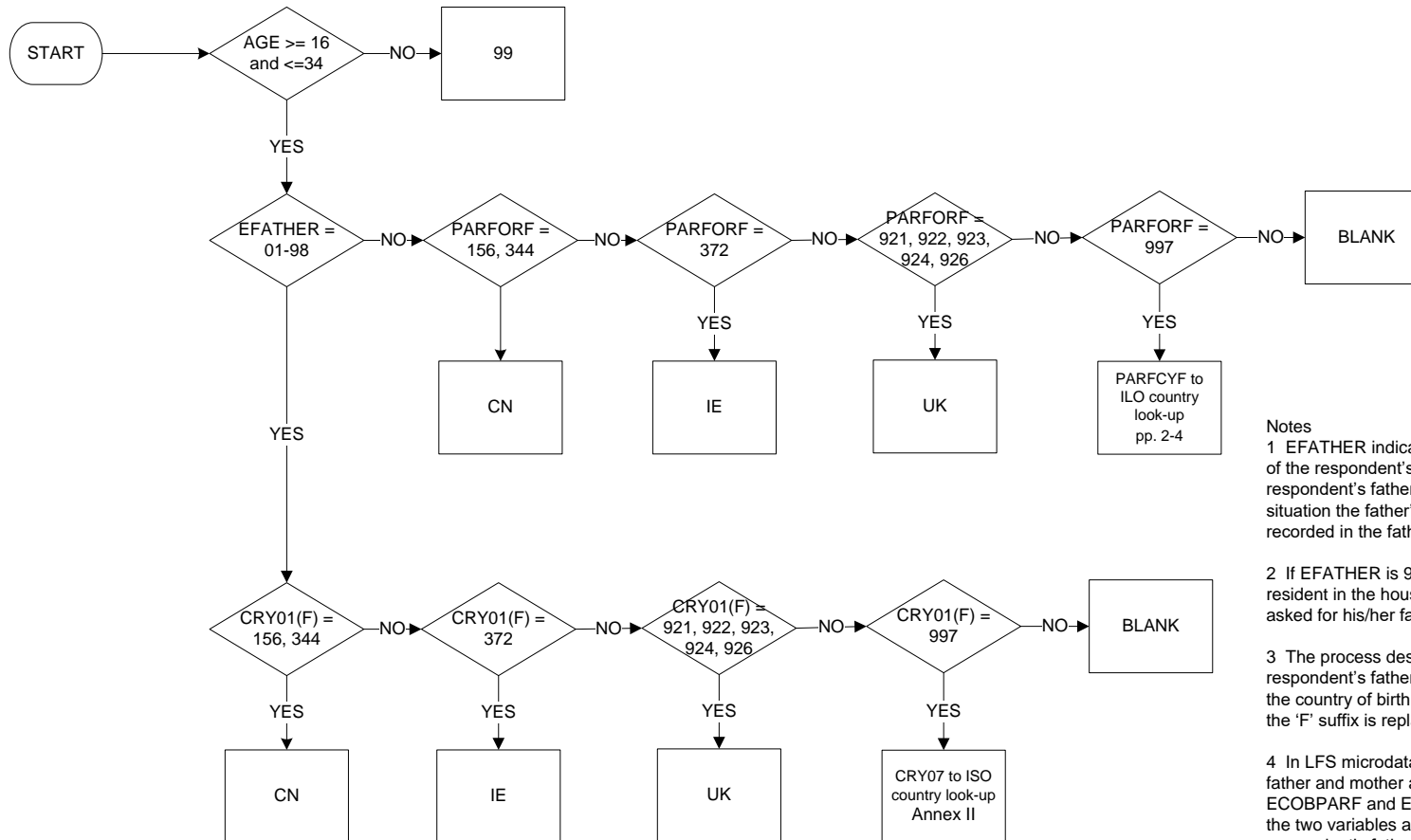

Notes

1 EFATHER indicates the sequence number in the household of the respondent's father. If in the range 01-98 then the respondent's father is a member of the household. In this situation the father's country of birth is taken from the data recorded in the father's own interview (CRY01 or CRY07).

2 If EFATHER is 99 then the respondent's father is not resident in the household. In this situation the respondent is asked for his/her father's country of birth.

3 The process described in the flowchart relates to the respondent's father; the same process is repeated to establish the country of birth of the respondent's mother. In which case the 'F' suffix is replaced by an 'M' suffix.

4 In LFS microdata the respective CoBs of the respondent's father and mother are presented as two distinct variables: ECOBPARF and ECOBPARM. In Eurostat data the values in the two variables are concatenated. For example, if the respondent's father's CoB is UK and the mother's CoB is IE then the resulting Eurostat value will be UKIE.

HATVOC (EHLEVED): Orientation of the highest level of formal education  
Eurostat AHM 2009 Column 208

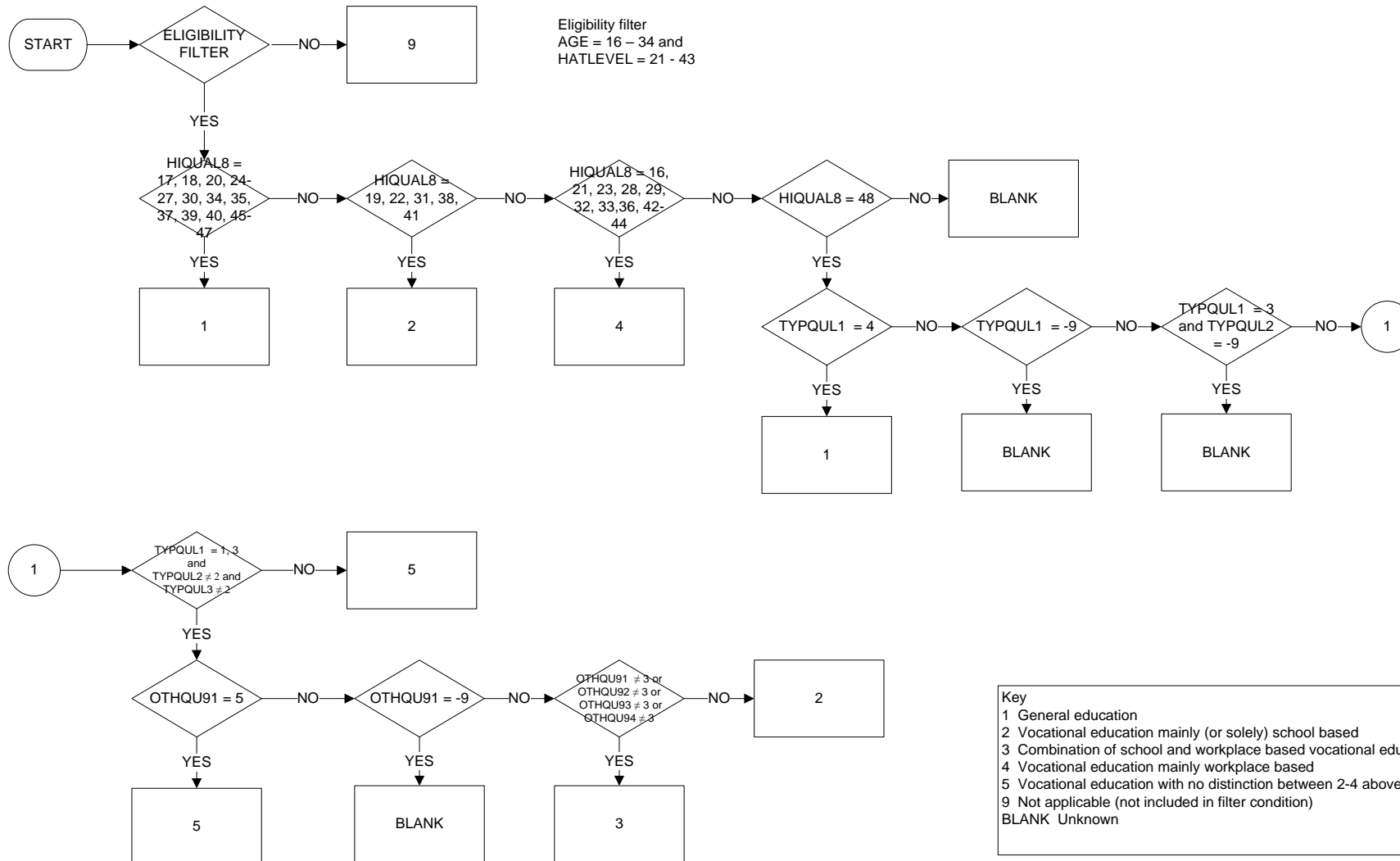

STOPDATE (ELEAVEDM/Y): Month and year of leaving formal education for the last time  
Eurostat AHM 2009 Columns 209-214

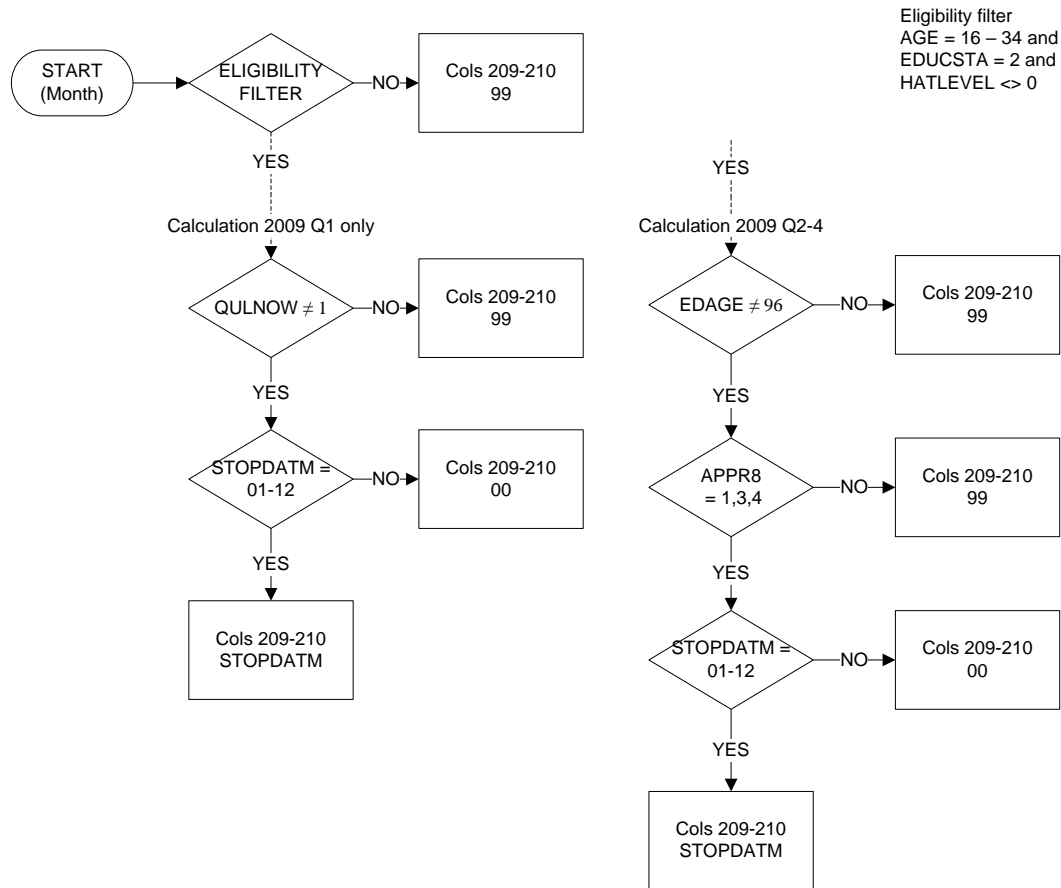

STOPDATE (ELEAVEDM/Y): Month and year of leaving leaving formal education for the last time  
Eurostat AHM 2009 Columns 209-214

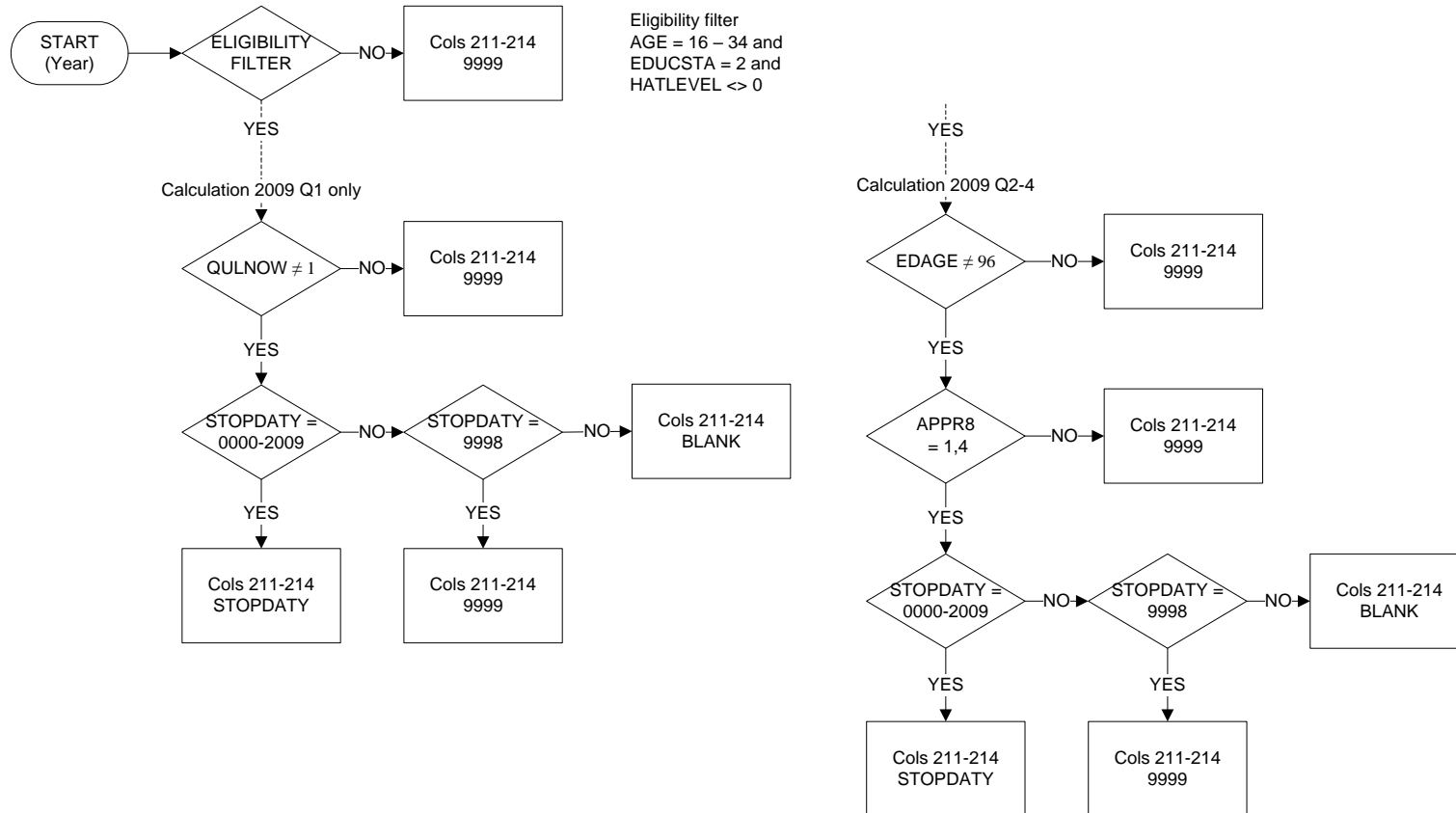

WORKEDUC (EWORKED): Work during studies in formal education  
Eurostat AHM 2009 Columns 215

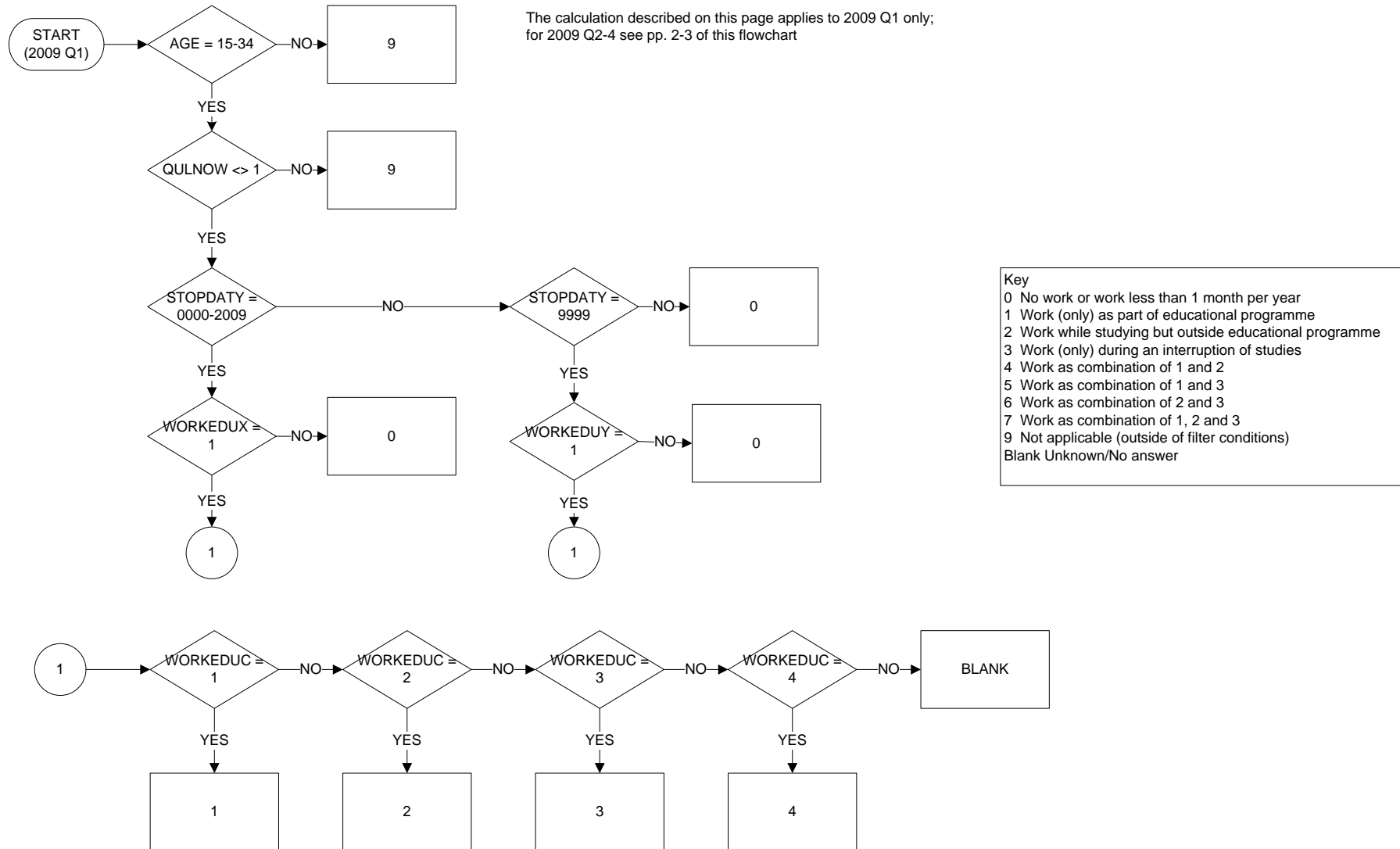

WORKEDUC (EWORKED): Work during studies in formal education  
Eurostat AHM 2009 Columns 215

Page 2 of 3  
Start date: Jan 2009  
End date: Dec 2009

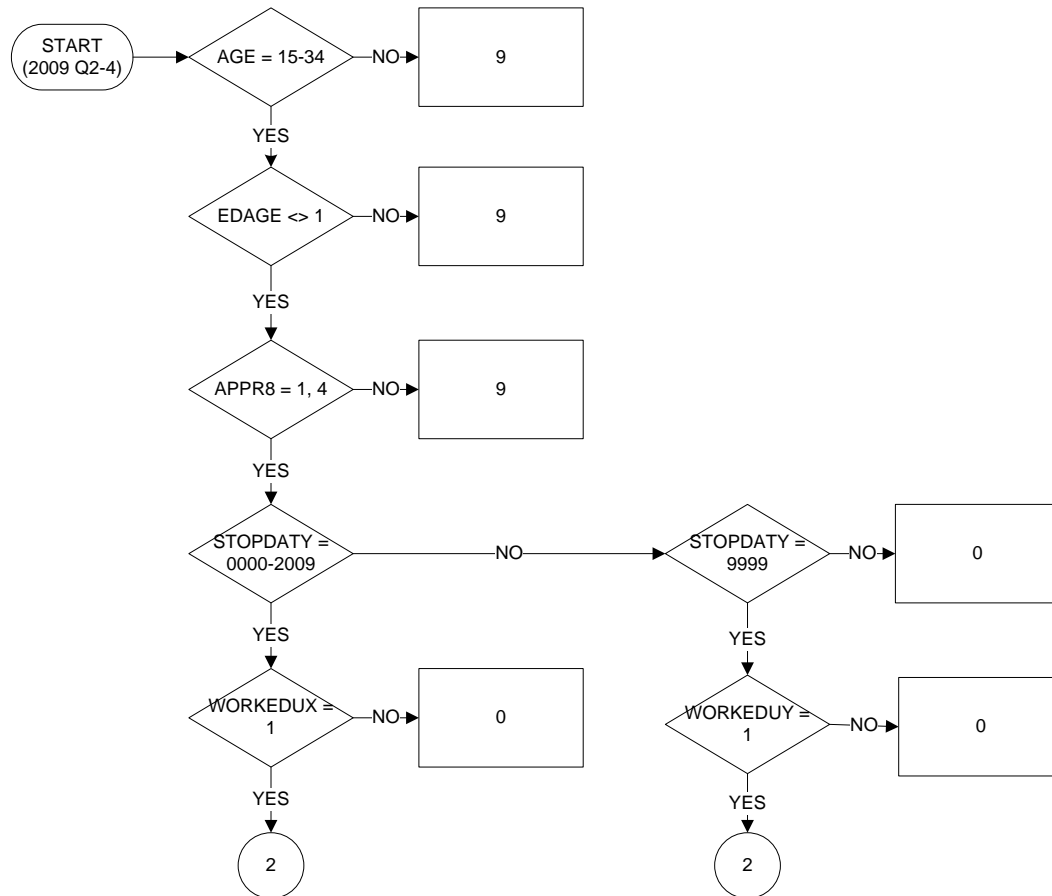

WORKEDUC (EWORKED): Work during studies in formal education  
Eurostat AHM 2009 Columns 215

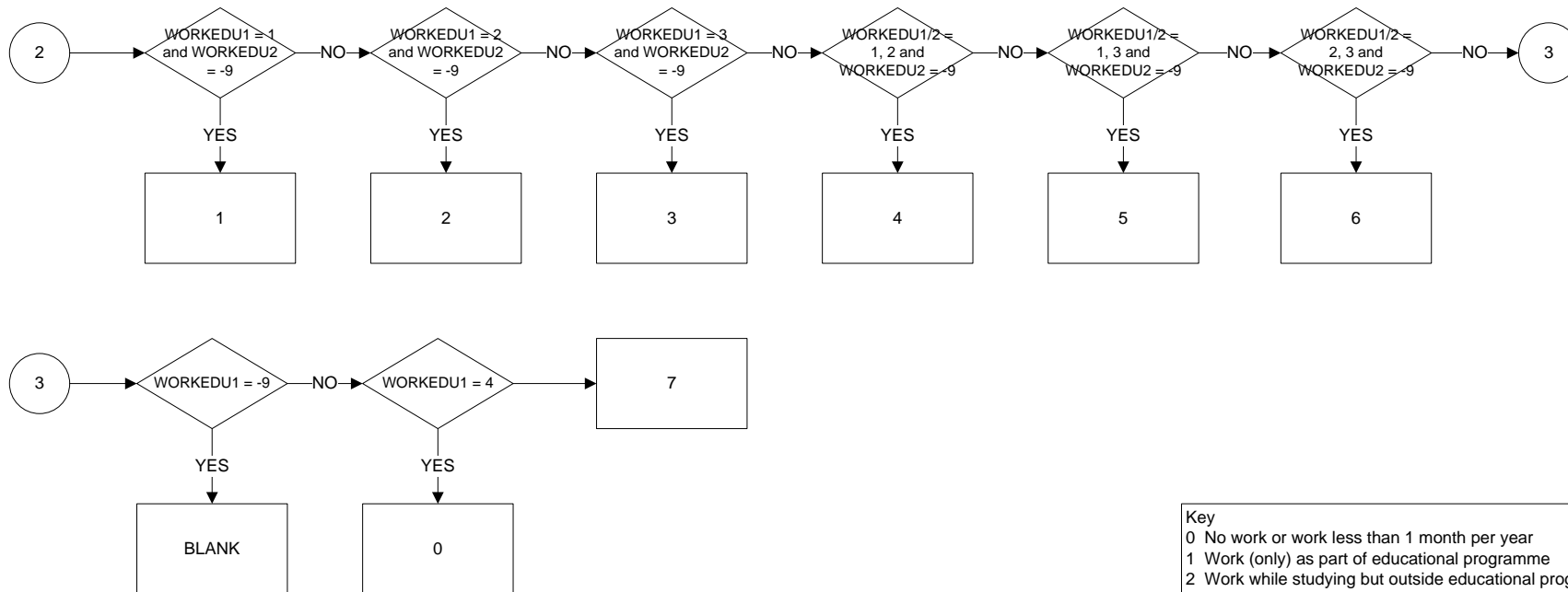

Key  
 0 No work or work less than 1 month per year  
 1 Work (only) as part of educational programme  
 2 Work while studying but outside educational programme  
 3 Work (only) during an interruption of studies  
 4 Work as combination of 1 and 2  
 5 Work as combination of 1 and 3  
 6 Work as combination of 2 and 3  
 7 Work as combination of 1, 2 and 3  
 9 Not applicable (outside of filter conditions)  
 Blank Unknown/No answer



JOBSTART (EFSTJOBM/Y): Month and year of start of the first job of more than 3 months after leaving formal education for the last time  
Eurostat AHM 2009 Columns 216-221

Calculation 2009 Q1 only

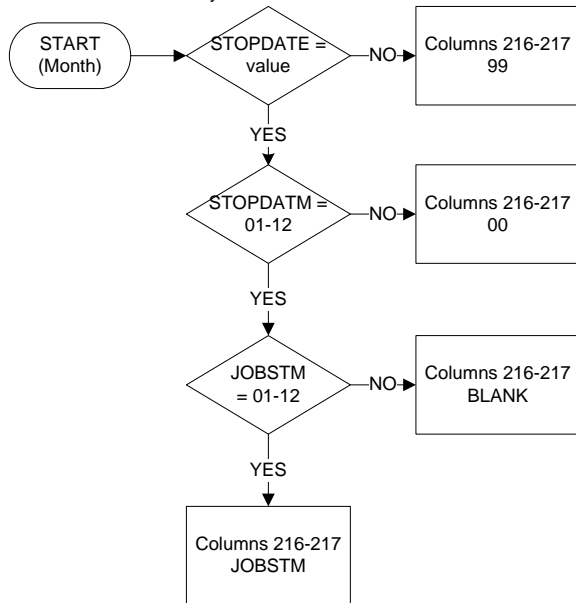

Calculation 2009 Q2 – Q4

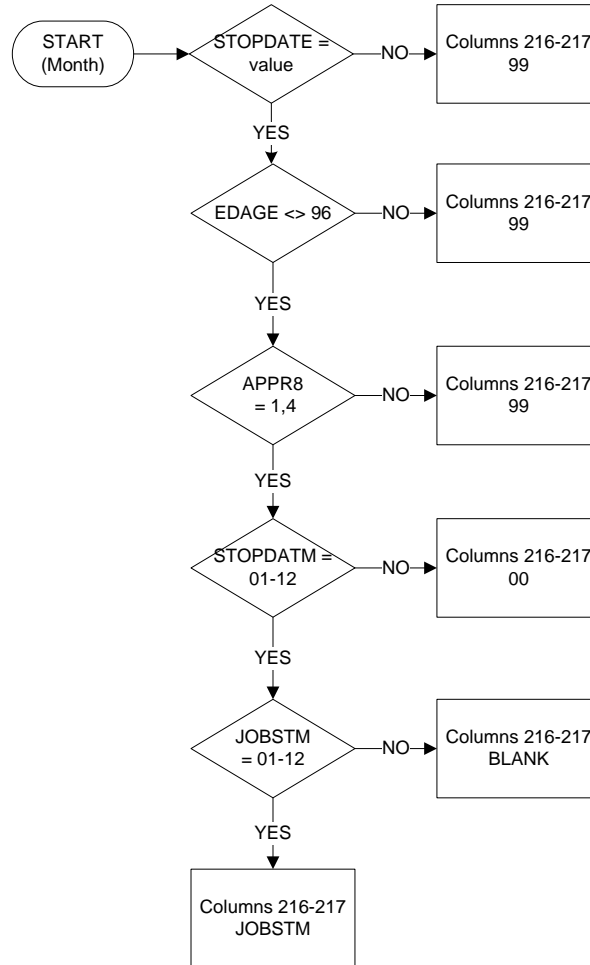

JOBSTART (EFSTJOBM/Y): Month and year of start of the first job of more than 3 months after leaving formal education for the last time  
Eurostat AHM 2009 Columns 216-221

Calculation 2009 Q1 only

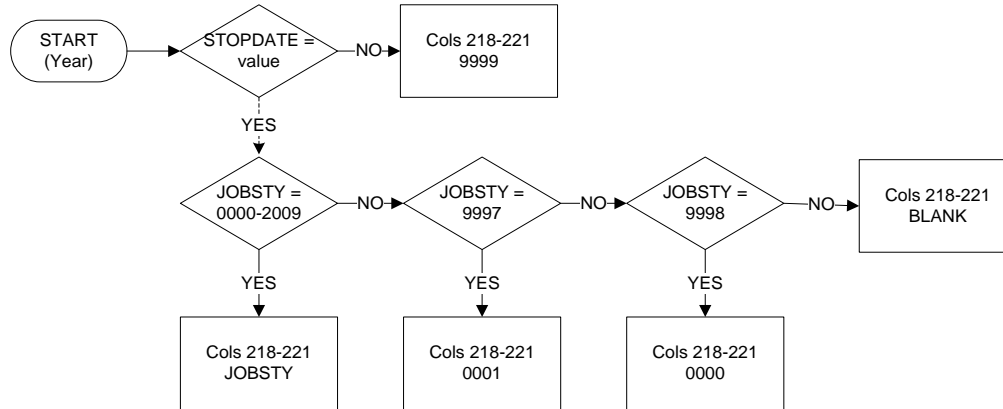

Calculation 2009 Q2 – Q4

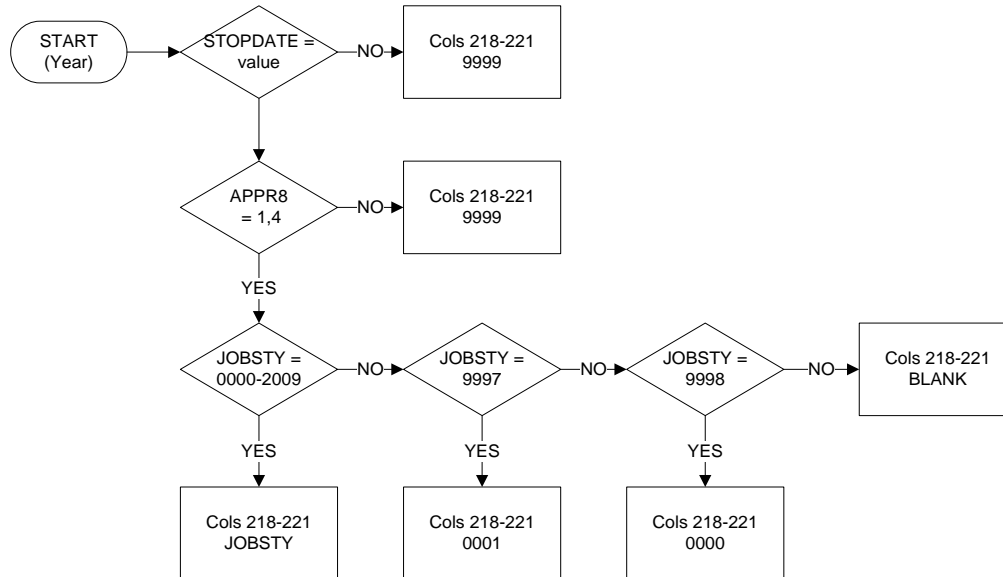

Key	
000000	Never had a job of more than three months
000001	Current job is first job
MMYYYY	Month and year
999999	Not applicable (outside filter conditions)
BLANK	Unknown / No answer

EJOB DUR (JOB DUR): Duration of the first job of more than 3 months (after leaving formal education for the last time)  
Eurostat AHM 2009 Columns 222-224

Page 1 of 1  
Start date: Jan 2009  
End date: Dec 2009

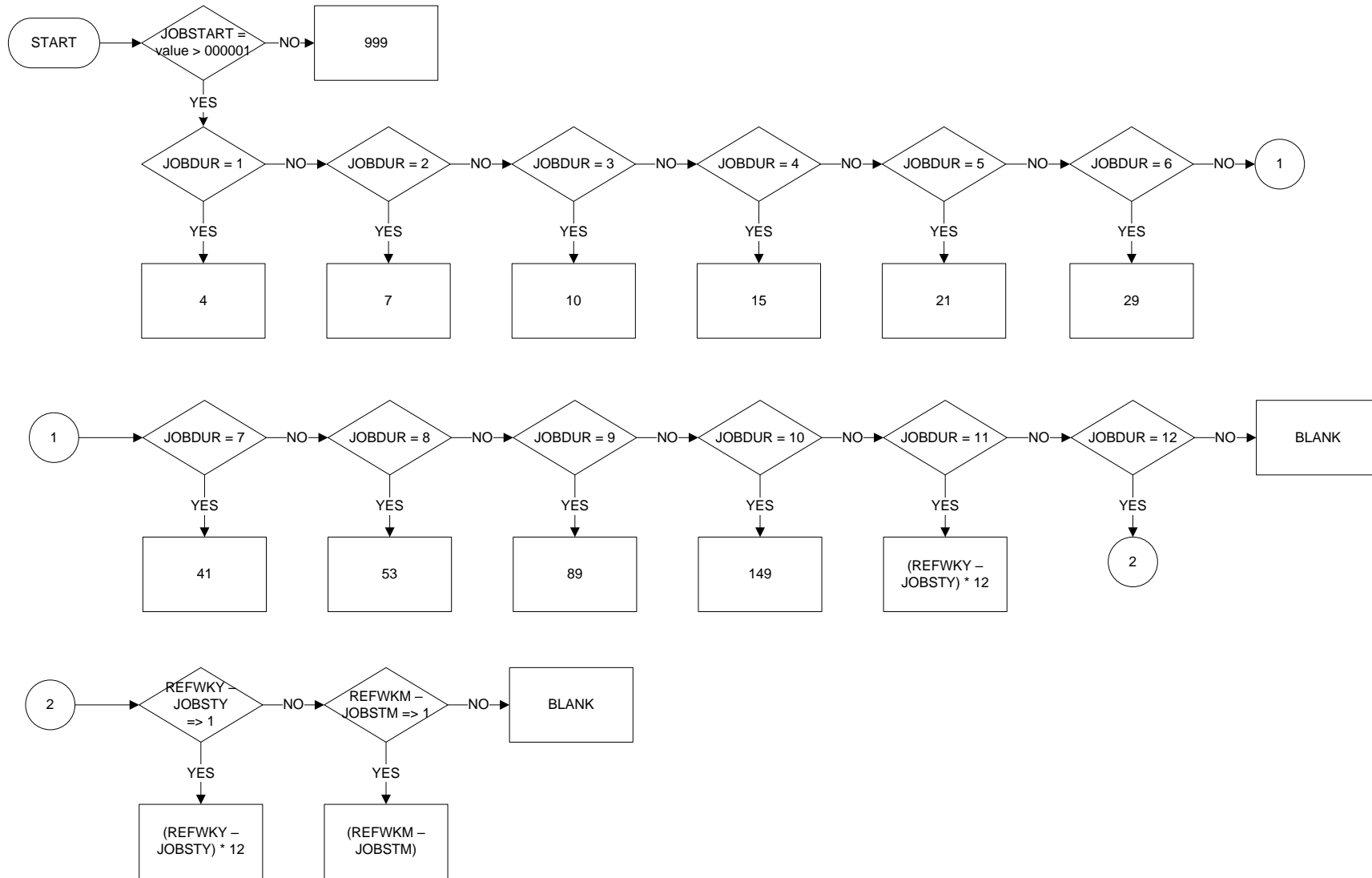

FINDMETH (EFINDJOB): Method which allowed to find the first job of more than 3 months (after leaving formal education for the last time)  
Eurostat AHM 2009 Column 225

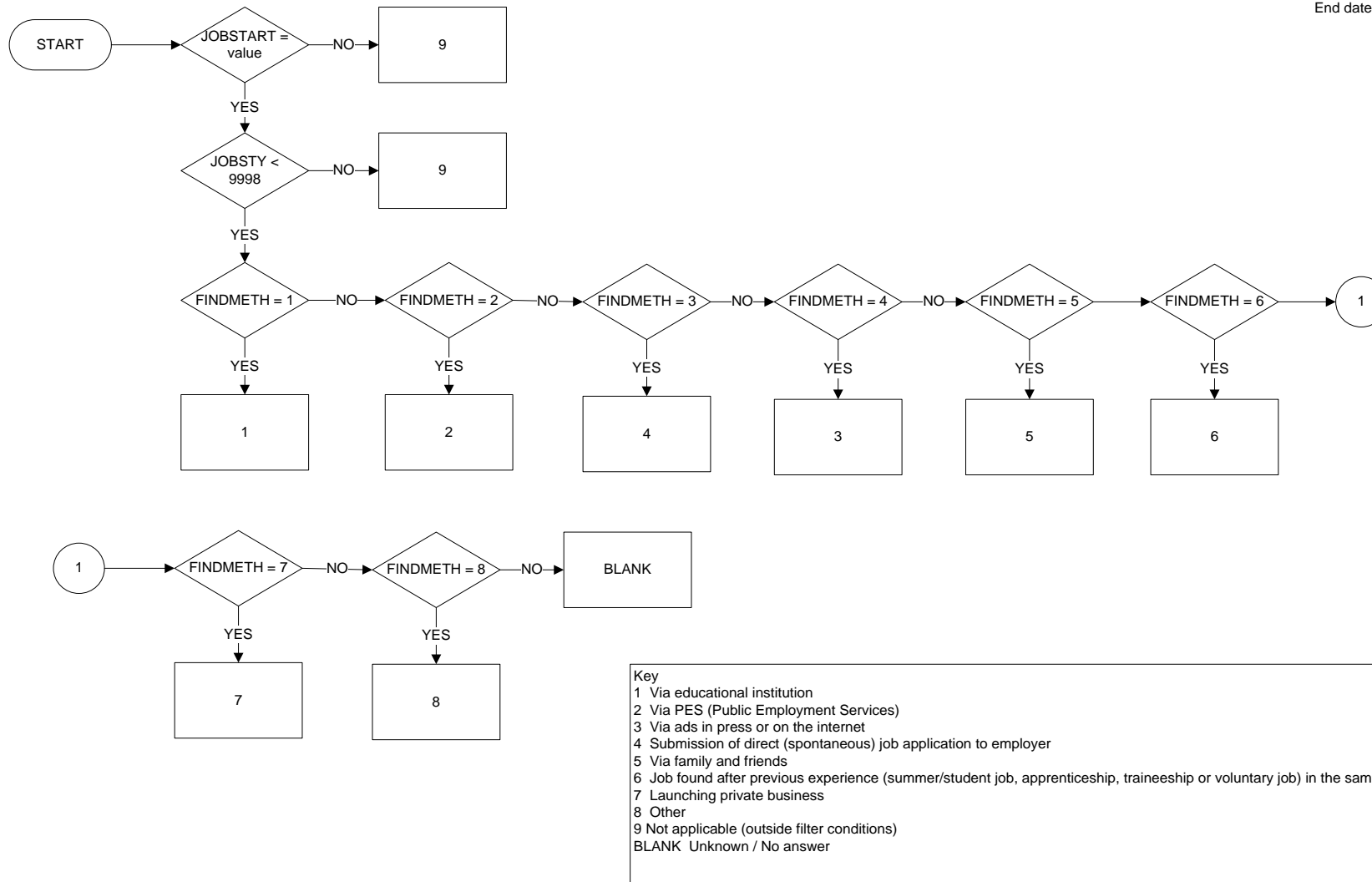

EJISCO (JOB OCC): Occupation of the first job of more than 3 months (after leaving formal education for the last time)  
Eurostat AHM 2009 Column 226-229

Page 1 of 1  
Start date: Jan 2009  
End date: Dec 2009

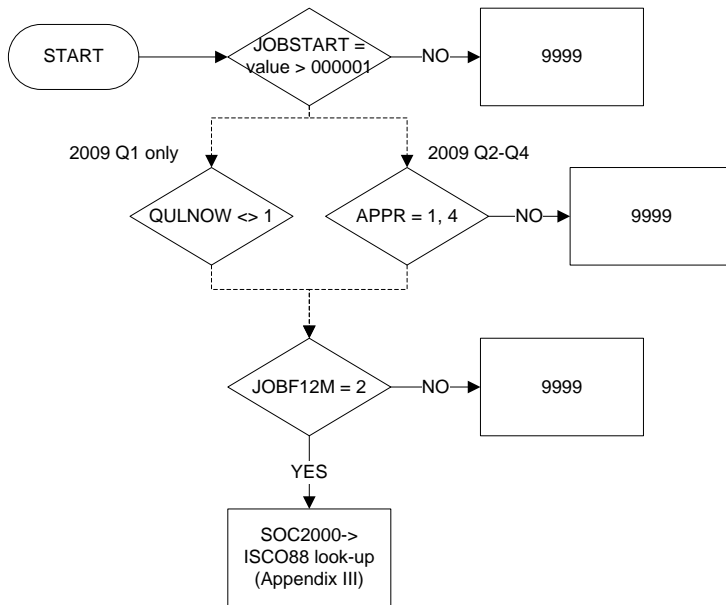

JOBCONTR (ECONTRTY): Type of contract of the first job of more than 3 months (after leaving formal education for the last time)  
Eurostat AHM 2009 Columns 230

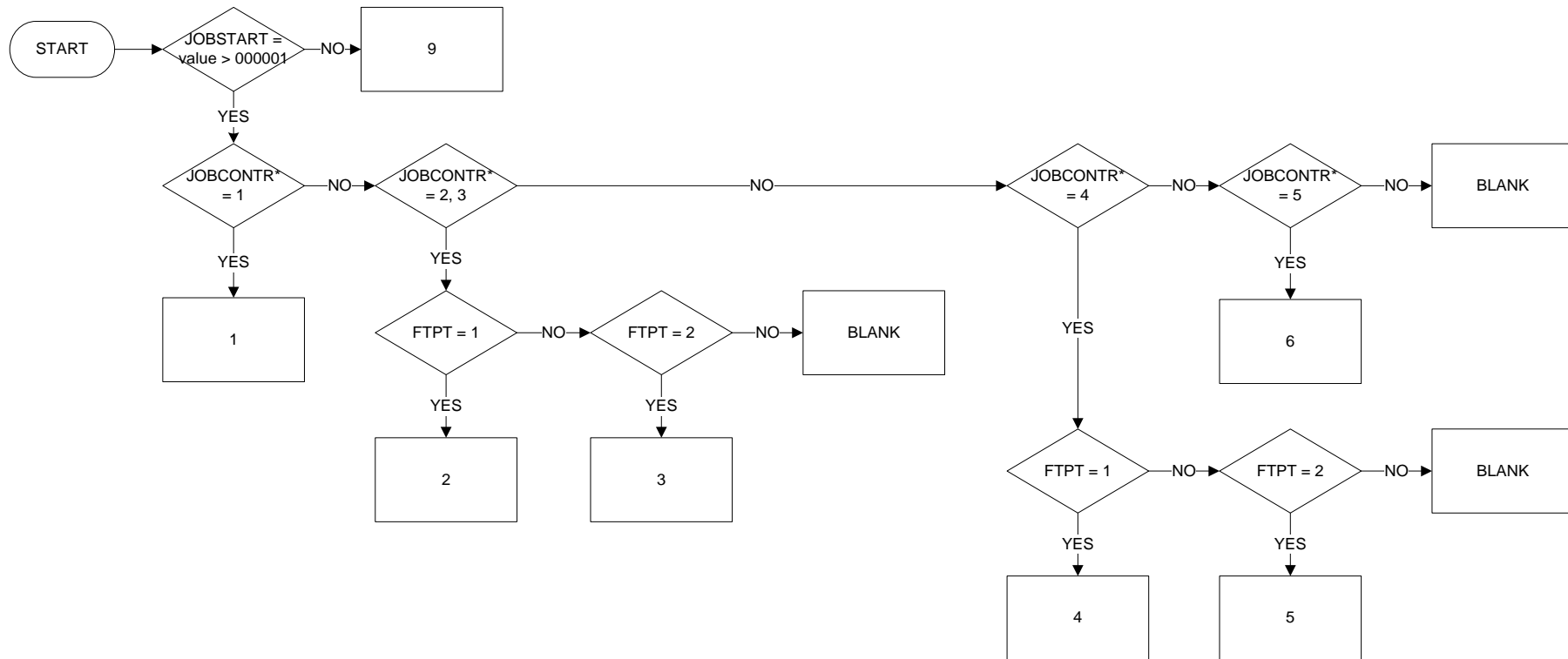

Key  
 1 Self-employed  
 2 Employee, permanent full-time  
 3 Employee, permanent part-time  
 4 Employee, temporary full-time  
 5 Employee, temporary part-time  
 6 Family worker  
 9 Not applicable (outside of filter conditions)  
 BLANK Unknown / No answer

Note  
 \* - denotes the questionnaire variable JOBCONTR. For details see LFS User Guide volume 2 2009, p. 122

TRANSACT (ETRANACT): Main activity after leaving formal education for the last time and before starting the first job of a duration of at least 3 months  
Eurostat AHM 2009 Columns 231

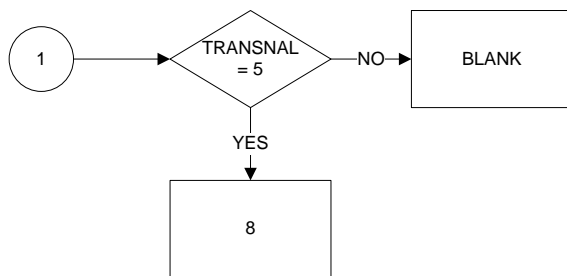
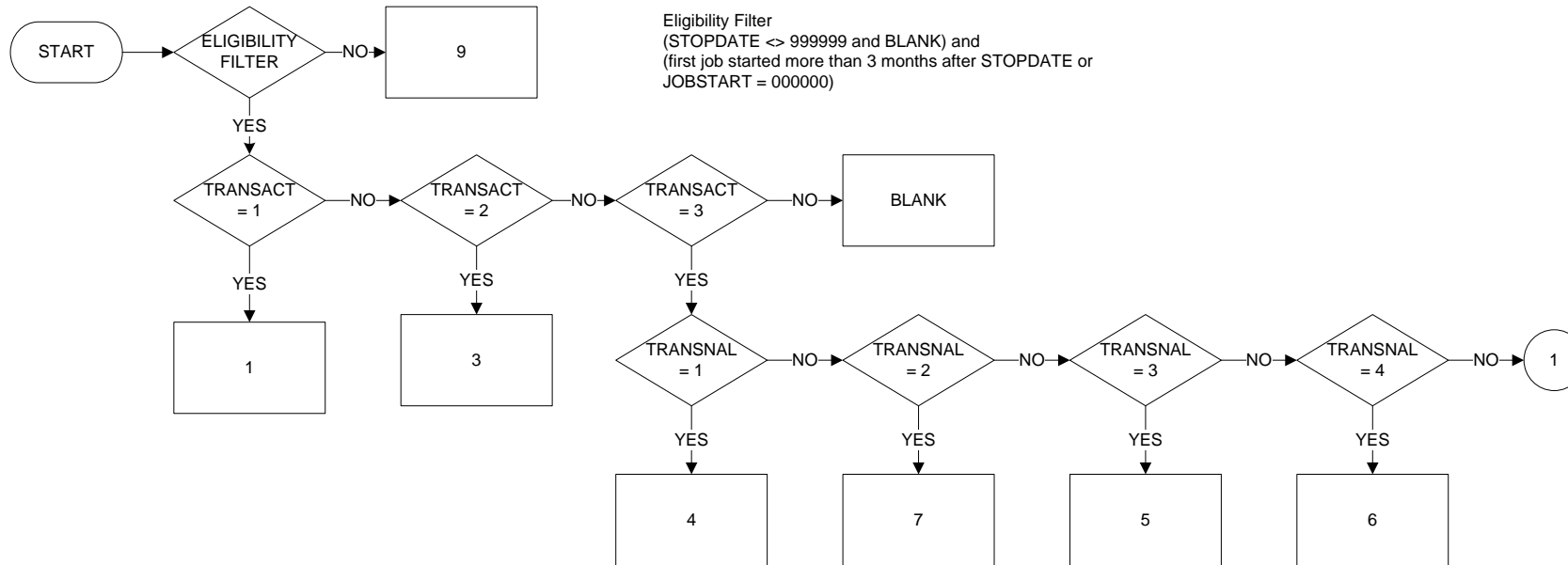

Key	
1	Employed – work in job(s) of short duration (max 3 months)
2	Compulsory military or community service
3	Not employed, actively looking for a job
Not employed, not looking for a job because...	
4	Family responsibilities
5	Participation in non-formal education
6	Voluntary activities
7	Health problems
8	Other reasons
9	Not applicable (Outside of filter condition)
BLANK	Unknown / No answer

## Explanatory Notes for LFS 2009 ad hoc module

### PARHAT Col 203

Highest level of education successfully completed by father or mother

This variable will need two questions (about father and mother separately).

Parents:

- If the father and the mother belong to the household, the information on their highest level of education can be taken from the core LFS without asking the question.
- Response to this question should be spontaneous.

If interviewee asks about which parents (biological or not) should be considered, the interviewer should ask him firstly on those with whom the person grew up (e.g. step mother/father rather than biological one not living in the same household). This question can also concern other persons with whom the interviewee spent most childhood (e.g. grand-parents).

In the case of doubts, parents could be defined as those living with the person around the age of 15 (the information on the educational level of parents should however correspond to the highest level achieved and not to the level achieved at the time the child was 15 years old). If the interviewee grew up with a single person, his/her educational level should be considered as "highest". People brought up in institutions should be coded blank.

- The level of education is coded according to the International Standard Classification of Education (ISCED 97). The NEACs (National Educational Attainment Classification) or other national classifications provide information about educational attainment according to the specific national situation. They constitute the basis for the recoding of national levels into the ISCED.
- At the European level, data on educational attainment of parents will only be coded according to three broad categories (low - medium - high). However, in the national questionnaires countries should collect the information at a sufficient level of detail in educational attainment that allows the allocation to the three categories, e.g. with regard to ISCED 3C short (less than 2 years of duration) which should be considered as low educational attainment.
- The expression "level successfully completed" must be associated with obtaining a certificate or a diploma, when there is a certification. Persons who have not completed their studies should be coded according to the highest level they have completed and should not be coded with a blank.

### PARFOR Col 204/207

Country of birth of father and mother

The first 2 digits correspond to the country of birth of the father and the 2 others to the country of birth of the mother. In the case of unknown country, code 00 for the mother or father should be used. The definition of parents should be the same as the one used in the previous variable.

This variable should be provided according to the coding given in Annex IV of the LFS explanatory notes (derived from ISO). If possible the exact country should be indicated; where this is not possible, one of the general groupings in bold print should be used. EU and EFTA Member States but also candidate and other European countries must be coded individually.



For the purpose of this question, current national boundaries should be considered, rather than any applying at the time of the respondent parents' birth. Some countries (those with colonial past or tradition of emigration) could add a variable on nationality at birth of parents with the aim to identify better foreign background of the young person: This variable is however optional.

### **HATVOC Col 208**

Orientation of the highest level of formal education attained (HATLEVEL)

This information will be collected only for persons with educational attainment at ISCED levels 2, 3 and 4.

Coding for this variable should be done together with the variables HATLEVEL and HATFIELD, using national classification of educational programmes, and preferably without asking any further questions.

The categories proposed are established according to the ISCED definitions applied in the UOE data collection and the VET (Vocational Education and Training) data collection as agreed by Member States (EUROSTAT/E3/2000/VET02, incl. a definition for VET).

1. General education: less than 25% of the programme content was vocational.
2. Vocational (and pre-vocational education): at least 25% of the programme content is vocational (specifically oriented towards a specific class of occupations or trades and leading to a labour-market relevant qualification).
  - *Vocational education and training mainly school-based*: at least 75% of the vocational education/training hours spent in a school, college or a training centre; the rest in a working environment (enterprise or other).
  - *Vocational education and training mainly workplace based*: at least 75% of the vocational education/training hours spent in a working environment (enterprise or other); the rest in a school, college or a training centre.
  - *Combination of school and workplace based vocational education and training* (e.g. dual system, alternate programmes): less than 75% of the vocational education/training hours spent in a school, college or a training centre, the rest in a working environment (enterprise or other)
    - remainder of the two above

If the information about the orientation of education can not be obtained directly from the list of programmes used for the variable HATLEVEL, indication done above on the criteria of distinction of different types of vocational education will be adopted to national situation with the aim to help the respondent. At least basic distinction between general and vocational education (code 1 versus 5) should be assured.

## **STOPDATE Col 209/214**

Month and year of leaving formal education for the last time

"Leaving" means leaving studies in formal education for the last time before the interview, regardless of whether the programme was successfully completed or not and even though the interviewee can have the intention to return to education in the future ("interruption").

Due to the difficulties faced by some countries for the identification of the date of leaving formal education for the last time, bilateral contacts between National Statistical Institutes and Eurostat are strongly encouraged. Examples or remarks which might be of interest for other Member States are uploaded on the FAQ webpage in reference at the beginning of this document.

As this variable serves as a reference point and filter for the variables concerning the first job, it is very important to obtain this information and to reduce non-answers to minimum.

The first 2 digits should be used for the month and the 4 following digits for the year (example: 052005 corresponds to May 2005). In the case of unknown month, code 00 for the month should be used.

## **WORKEDU Col 215**

Work during studies in formal education

The question should be asked to the persons who have already finished their formal education as well as to the current students. The whole period of studies should be taken into account (not only the last level of education).

"Work" means here a job for pay or profit, of a minimal duration of about 1 month per year, on average: this can be expressed as approximately 4 weeks full-time, 8 weeks part-time or 150 hours within a year (not as 1 month adding up all employment spells for the whole period of studies). The purpose being to avoid reporting on very minor jobs but without increasing the burden on respondents, a reference to at least one month for a given year would be acceptable.

Two main purposes justify this variable:

- to detect the 1<sup>st</sup> experience in the labour market (search for a job, schedules, pay..) which can have a positive impact on the entry into the labour market after the studies
- to distinguish the work performed as a part of the educational programmes completed (since this will not be possible for all countries via the variable HATVOC)

Code 1: "Work as part of educational programme" means that a workplace based element is a compulsory part of the curriculum, such as in apprenticeship or dual system programmes or compulsory internships. Working during school holidays should be coded 2.

Interruptions of studies should be those of at least one school/academic year.

### **JOBSTART Col 216/221**

Month and year of start of the first job of more than 3 months after leaving formal education for the last time

Only jobs for pay or profit of more than 3 months should be taken into account. This job could have started before leaving education although it was still the first job after leaving education. In that case JOBSTART will be before STOPDATE. If the current job is a first job but of the duration of less than 3 months (counted in the reference week), code 000000 should be used. Apprenticeship/unpaid traineeship, compulsory military or community service and summer jobs should be excluded.

The first 2 digits should be used for the month and the 4 following digits for the year (ex: 052005 correspond to May 2005). In the case of unknown month code 00 for the month should be used.

### **JOB DUR Col 222/224**

Duration of the first job of more than 3 months (after leaving formal education for the last time)

Only jobs for pay or profit of more than 3 months should be taken into account. This job could have started before leaving education although it was it was the first job after leaving education. In that case, the duration should be counted from JOBSTART. Apprenticeship/unpaid traineeship, compulsory military or community service and summer jobs should be excluded.

The question could be asked in terms of exact months first and in case of difficulties in time bands of 3 months could be proposed and the average point of the band could be provided.

### **FINDMETH Col 225**

Method which allowed to find the first job of more than 3 months (after leaving formal education for the last time)

We are asking about the main successful method which allowed the respondent to find the first job.

Code 2 means that the person was informed of the existence of this first job by the Public Employment Services. The information can come directly or via the internet site of the PES.

### **JOB OCC Col 226/229**

Occupation of the first job of more than 3 months (after leaving formal education for the last time)

The variable should be coded according to the ISCO 88-COM classification, at 3- or 4-(optional)-digits-level. For those countries that are not able to provide information at a 4 digit level the fourth digit should be coded '0'. We ask for the occupation when the first job started.

## **JOBCONTR Col 230**

Type of contract of the first job of more than 3 months (after leaving formal education for the last time)

Please see explanatory notes for the 2008 LFS explanatory notes for the variable STAPRO (professional status).

Employees with a temporary contract are employees whose main job will terminate either after a period fixed in advance, or after a period not known in advance, but nevertheless defined by objective criteria, such as the completion of an assignment or the period of absence of an employee temporarily replaced. In case that there was a probationary period when starting the job followed by a contract of unlimited duration, the job should nevertheless be reported as a permanent job.

This variable is about the type of the 1<sup>st</sup> contract, even it has changed after, but excluding probationary periods (see previous bullet). The distinction between full-time and part-time work should be made on the basis of a spontaneous answer given by the respondent.

## **TRANSACT Col 231**

Main activity after leaving formal education for the last time and before starting the first job of a duration of at least 3 months

We are asking about the main activity. In case of various activities, respondent could choose the activity with the longest duration. Holidays after stopping education should be excluded (the question asks about the period after stopping formal education and after holidays if the person took them).

“Work” means a job for pay or profit. Unpaid apprenticeship should be included in "other reasons".

## **Col 232/237**

Weighting factor

Columns 232/237 should be filled for the countries where the weighting factor for the LFS module 2009 is different to the weighting factor for the core LFS (e.g. proxies allowed in the core LFS but not for the module, specific non-response rate high for the module compared to the core LFS ...).

## **PARFOR Col 238**

Nationality at birth of father and mother (optional)

The first 2 digits correspond to the nationality of the father and the 2 others to the nationality of the mother. Nationality should be interpreted as citizenship. Citizenship is defined as the particular legal bond between an individual and his/her state acquired by birth or naturalisation, whether by declaration, option, marriage or other means according to national legislation. It corresponds to the country issuing the passport. The concept of nationality should not be mixed up with any concept of ethnic origin.

For persons with dual or multiple citizenships, and who hold the citizenship of the country of residence, that citizenship should be coded. In case of multiple citizenship, where it includes one citizenship of a

member state of the European Union, that citizenship should be coded. In other situations the first answer of the respondent should be coded.

This variable should be provided according to the coding given in Annex IV of the LFS explanatory notes (derived from ISO). If possible the exact nationality should be indicated; where this is not possible, one of the general groupings in bold print should be used. EU and EFTA Member States but also candidate and other European countries must be coded individually.

**Specifications of the 2008 ad hoc module on the labour market situation of migrants and their immediate descendants**

Column	Code	Description	Filter
203/206	YEARCITI  9996 9997 9998 9999 Blank	<i>Year of acquisition of citizenship</i> 4 digits Year unknown but national by acquisition National at birth National since the creation of the country/redefinition of borders Not applicable (person aged under 15 or over 74 or (person aged 15-74 and C17/18 ≠ C170/171)) No answer	Everybody aged 15-74 and C17/18 = C170/171
207/208	COBFATH  98 99 blank	<i>Country of birth of father</i> <i>(For Germany: nationality/former nationality of father when he has in the reference week the German nationality)</i> For coding see ISO classification Country unknown but father born abroad Not applicable (person aged under 15 or over 74) No answer	Everybody aged 15-74
209/210	COBMOTH  98 99 blank	<i>Country of birth of mother</i> <i>(For Germany: nationality/former nationality of father when he has in the reference week the German nationality)</i> For coding see ISO classification Country unknown but father born abroad Not applicable (person aged under 15 or over 74) No answer	Everybody aged 15-74
211/212	TOTRESID 01-98 99 Blank	<i>Total number of years of residence in host country</i> 2 digits Not applicable (person aged under 15 or over 74 and C19/20 = 00)) No answer	Everybody aged 15-74 and C19/20 ≠ 00
213	MIGREAS 1 2 3 4 5 6 7 8 9 Blank	<i>Main reason the person had for migrating (last migration)</i> Employment, intra-corporate transfer Employment, job found before migrating other than code 1 Employment, no job found before migrating Study International protection Accompanying family / family reunification Family formation Other Not applicable (person aged under 15 or over 74 or (person aged 15-74 and C19/20 = 00) or (person aged 15-74 and C19/20 ≠ 00 and (C162/165 – C11/14 – C19/20) < 15)) No answer	Everybody aged 15-74 and C19/20 ≠ 00 and (C162/165 – C11/14 – C19/20) ≥ 15

Column	Code	Description	Filter
214	DURLIM 0 1-5 6 7 8 9 Blank	<i>Whether the duration of the current residence permit/visa/certificate is limited (optional for France)</i> Yes, less than 1 year Yes, number of years Yes, limited duration of more than 5 years Yes, but do not know the duration No Not applicable (person aged under 15 or over 74 or (person aged 15-74 and C17/18 = C170/171)) No answer	Everybody aged 15-74 and C17/18 ≠ C170/171
215	RESTRACC 1 2 3 4 5 6 7 8 9 Blank	<i>Whether current legal access to the labour market is restricted</i> Yes, access restricted to employment for specific employers/sectors/occupations Yes, access restricted to self-employment Yes, access not allowing self-employment Yes, combination of 1 and 2 Yes, combination of 1 and 3 Yes, combination of 1 and 3 No Does not know Not applicable (person aged under 15 or over 74 or (person aged 15-74 and C17/18 = C170/171) or (person aged 15-74 and C17/18 ≠ C170/171 and C116 = 2, blank)) No answer	Everybody aged 15-74 and C17/18 ≠, C170/171 and (C24 = 1, 2 or C99 = 1, 2, 4 or (C99 = 3 and C116 = 1))
216	ESTQUALI 1 2 3 4 5 9 Blank	<i>Use of facilities for establishing what highest qualification equates to in the host country system</i> Yes, established what qualification equates to Yes, but not established what qualification equates to or procedure not yet completed No, no need because highest qualification obtained in the host country No, no need for reason other than code 3 No for other reason Not applicable (person aged under 15 or over 74 or (person aged 15-74 and C19/20 = 00) or (person aged 15-74 and C19/20 ≠ 00 and C116 = 2, blank)) No answer	Everybody aged 15-74 and C19/20 ≠ 00 and (C24 = 1, 2 or C99 = 1, 2, 4 or (C99 = 3 and C116 = 1))

## Labour Force Survey – United Kingdom

Column	Code	Description	Filter
217	IMPLANG 1 2 9 Blank	<i>Need to improve host country language skills to get an appropriate job</i> Yes No Not applicable (person aged under 15 or over 74 or (person aged 15-74 and C19/20 = 00) or (person aged 15-74 and C19/20 ≠ 00 and C116 = 2, blank)) No answer	Everybody aged 15-74 and C19/20 ≠ 00 and (C24 = 1, 2 or C99 = 1, 2, 4 or (C99 = 3 and C116 = 1))
218	HELPFING 1 2 3 4 5 6 9 Blank	<i>Main help received in the host country in finding the current job or setting up own business</i> Relatives/friends Public employment office Private employment agencies Migrant or ethnic organisation Other None Not applicable (person aged under 15 or over 74 or (person aged 15-74 and C24 = 3, 4, 5)) No answer	Everybody aged 15-74 and C24 = 1, 2
219/220	SERVINT 01 02 03 04 05 06 07 08 09 99 Blank	<i>Use of services for labour market integration in the two years following the last arrival</i> Yes, contact with an adviser for job guidance/counselling or job search assistance Yes, participation to labour market training/programmes Yes, participation to host country language tuition Yes, combination of 1 and 2 Yes, combination of 1 and 3 Yes, combination of 2 and 3 Yes, combination of 1, 2 and 3 No, not entitled to No, for reason other than code 8 Not applicable (person aged under 15 or over 74 or (person aged 15-74 and C19/20 = 00) or (person aged 15-74 and C19/20 ≠ 00 and C19/20 > 10) or (person aged 15-74 and C19/20 ≠ 00 and C19/20 ≤ 10 and (C162/165 – C11/14 – C19/20) < 15)) No answer	Everybody aged 15-74 and C19/20 ≠ 00 and C19/20 ≤ 10 and (C162/165 – C11/14 – C19/20) ≥ 15
221/226	0000 - 9999 00 - 99	<i>Weighting factor for the 2008 LFS module (optional)</i> Columns 220-223 contain whole numbers Columns 224-226 contain decimal places	Everybody aged 15-74



YEARCITI (ECITIZEN): Year of acquisition of citizenship  
Eurostat AHM 2008 Column 203-206

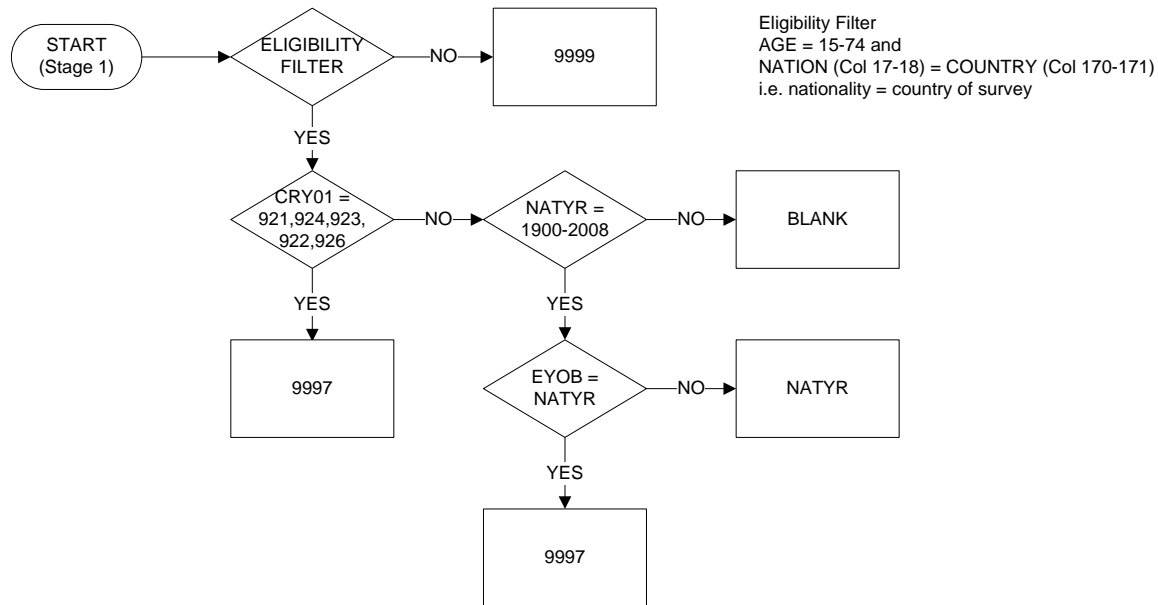

Key	
1900 – 2008	Year of acquisition of citizenship
9996	Year unknown but national by acquisition
9997	National at birth
9999	Not applicable (outside filter conditions)
BLANK	Unknown / No answer

COBFATH (ECOBFAT) Country of birth of father  
Eurostat AHM 2008 Columns 207-208

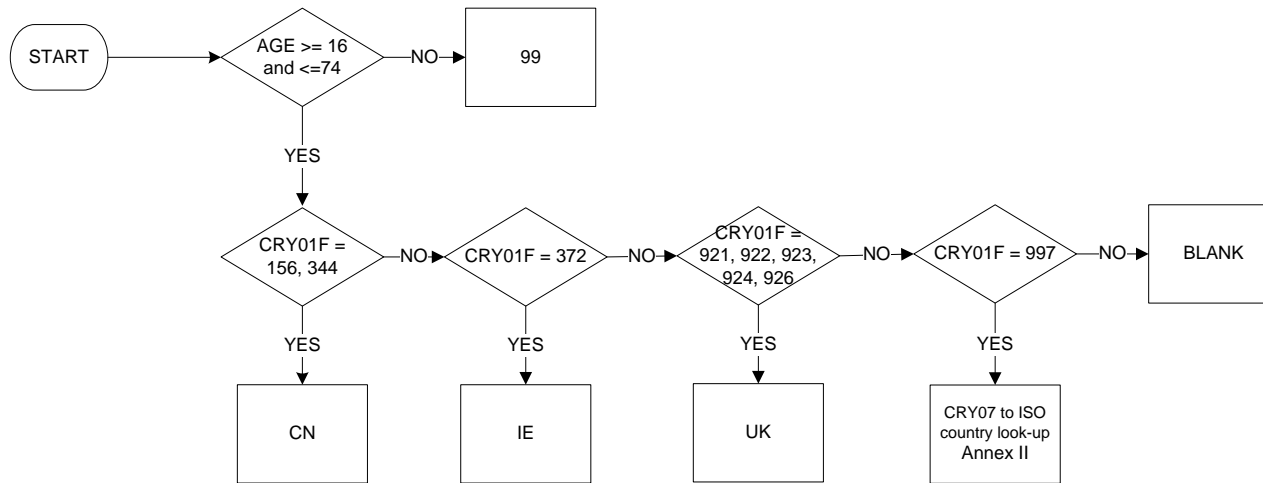

<b>CRY01F</b>	
156	China
344	Hong Kong
372	Republic of Ireland
921	England
922	Northern Ireland
923	Scotland
924	Wales
926	UK, Britain NOS
997	Other

COBMOTH (ECOBMOT) Country of birth of mother  
Eurostat AHM 2008 Columns 209-210

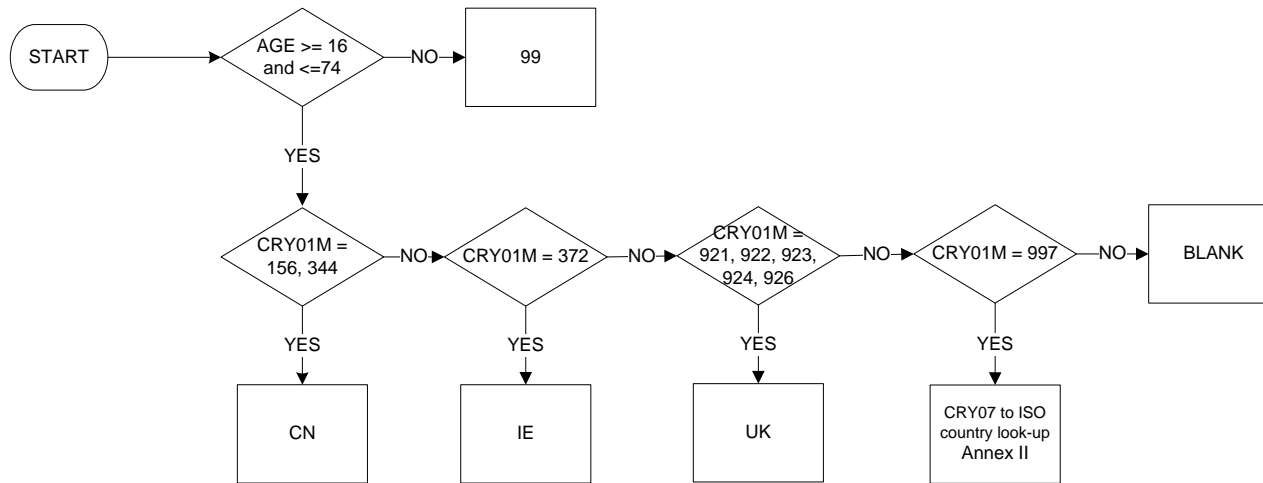

<b>CRY01M</b>	
156	China
344	Hong Kong
372	Republic of Ireland
921	England
922	Northern Ireland
923	Scotland
924	Wales
926	UK, Britain NOS
997	Other

TOTRESID (EUKYRS): Total number of years of residence in the host country  
Eurostat AHM 2008 Columns 211-212

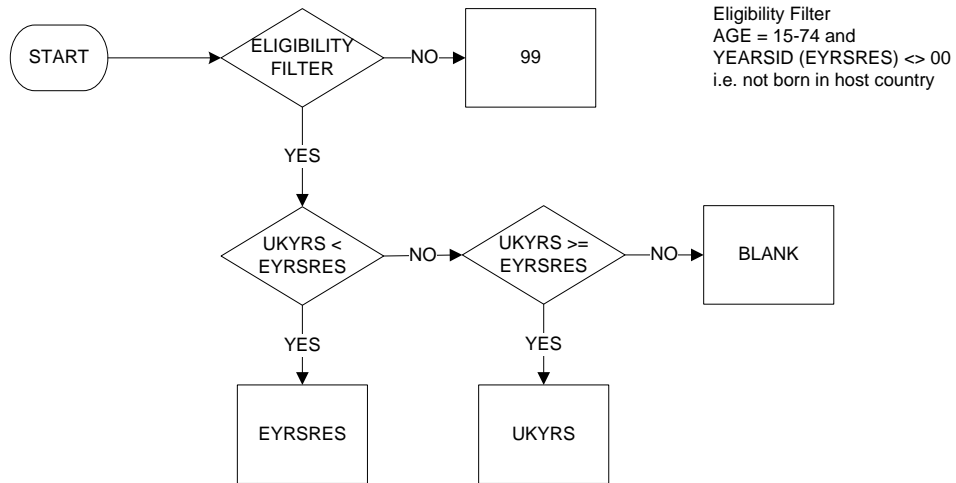

MIGREAS (EWHYUK): Main reason for migrating  
Eurostat AHM 2008 Columns 213

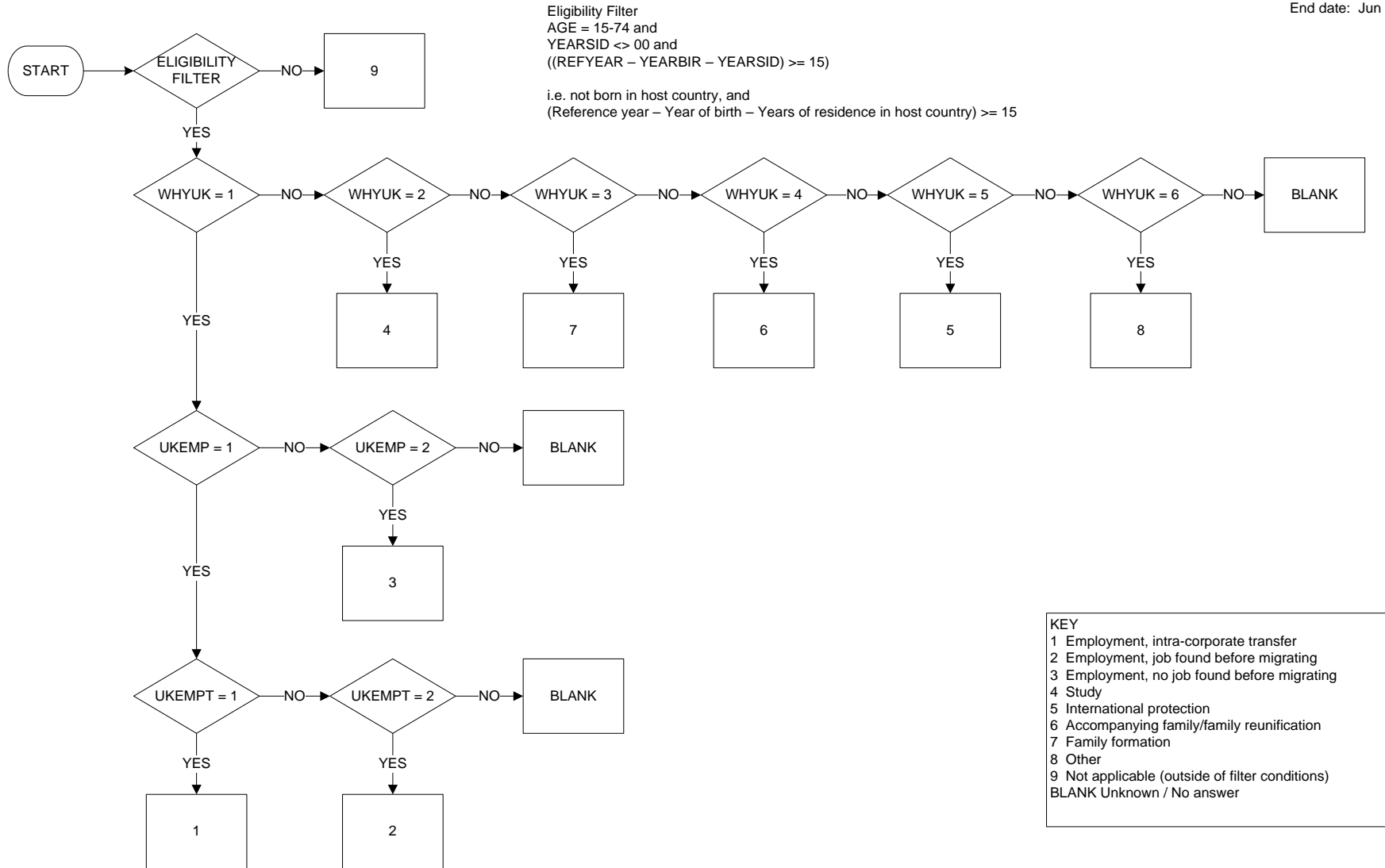

DURLIM (EPERMIT): Whether the duration of the current residence permit/visa/certificate is limited  
Eurostat AHM 2008 Columns 214

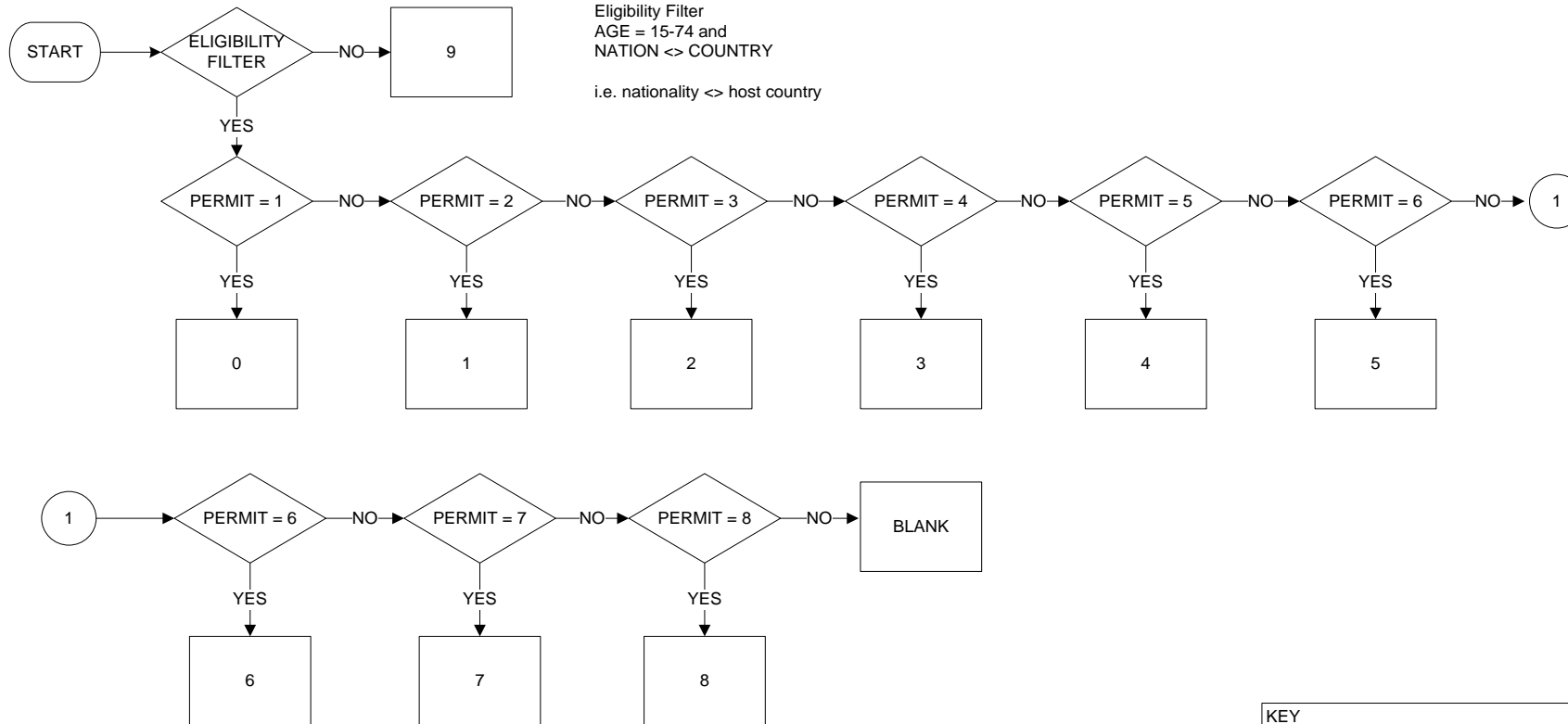

KEY	
0	Yes, less than 1 year
1-5	Yes, number of years
6	Yes, limited duration of more than 5 years
7	Yes, but do not know duration
8	No
9	Not applicable (outside of filter conditions)
BLANK	Unknown / No answer

RESTRACC (EACCESS): Whether current legal access to the labour market is restricted  
Eurostat AHM 2008 Columns 215

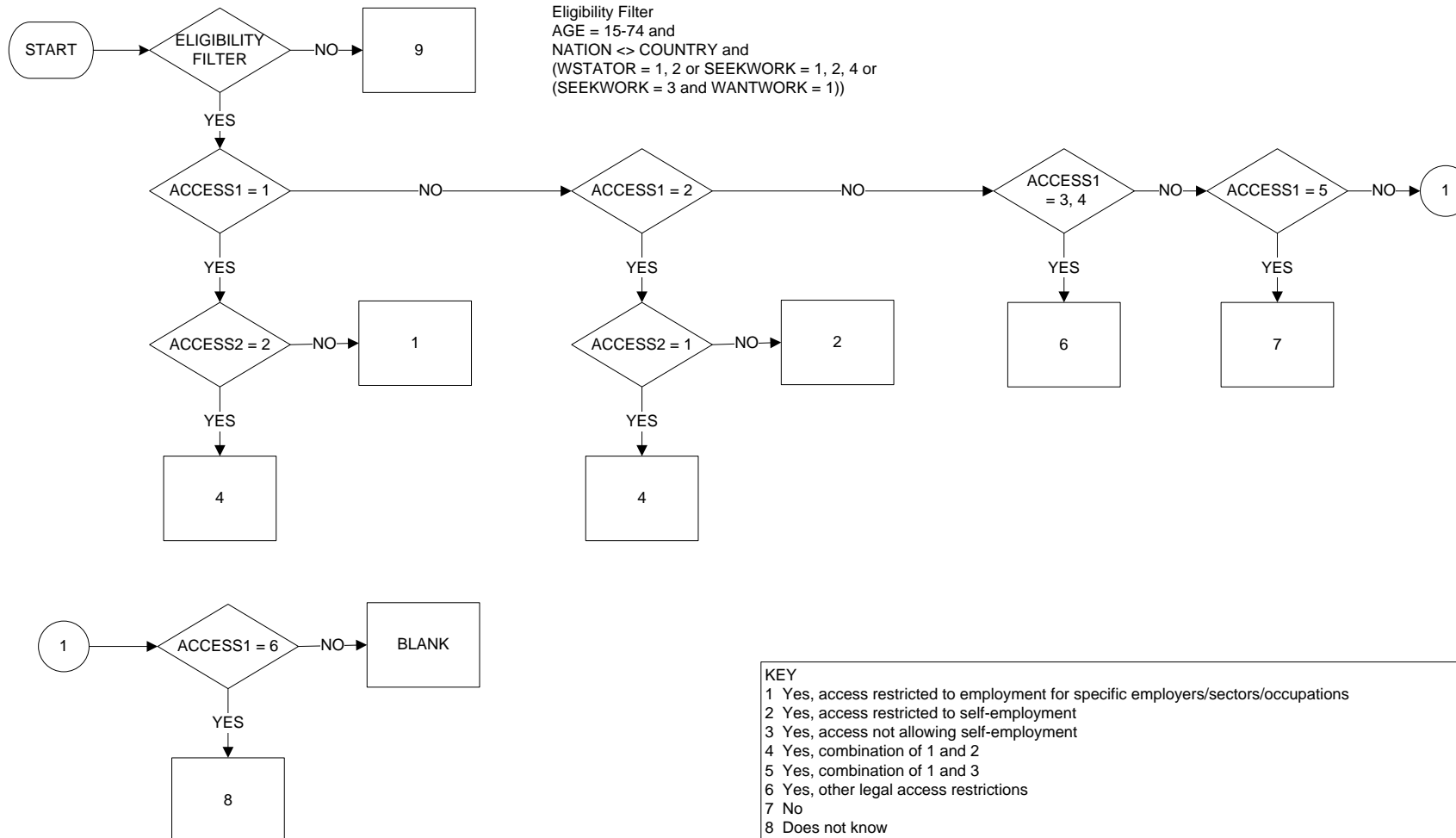

**KEY**  
 1 Yes, access restricted to employment for specific employers/sectors/occupations  
 2 Yes, access restricted to self-employment  
 3 Yes, access not allowing self-employment  
 4 Yes, combination of 1 and 2  
 5 Yes, combination of 1 and 3  
 6 Yes, other legal access restrictions  
 7 No  
 8 Does not know  
 9 Not applicable (person aged under 15 or over 74 or UK citizen or not working or not looking for/wanting work)  
 BLANK Unknown / No answer

ESTQUALI (EQUALUK): Use of facilities for establishing what highest qualification equates to in the host country system  
Eurostat AHM 2008 Columns 216

Page 1 of 1  
Start date: Apr 2008  
End date: Jun 2008

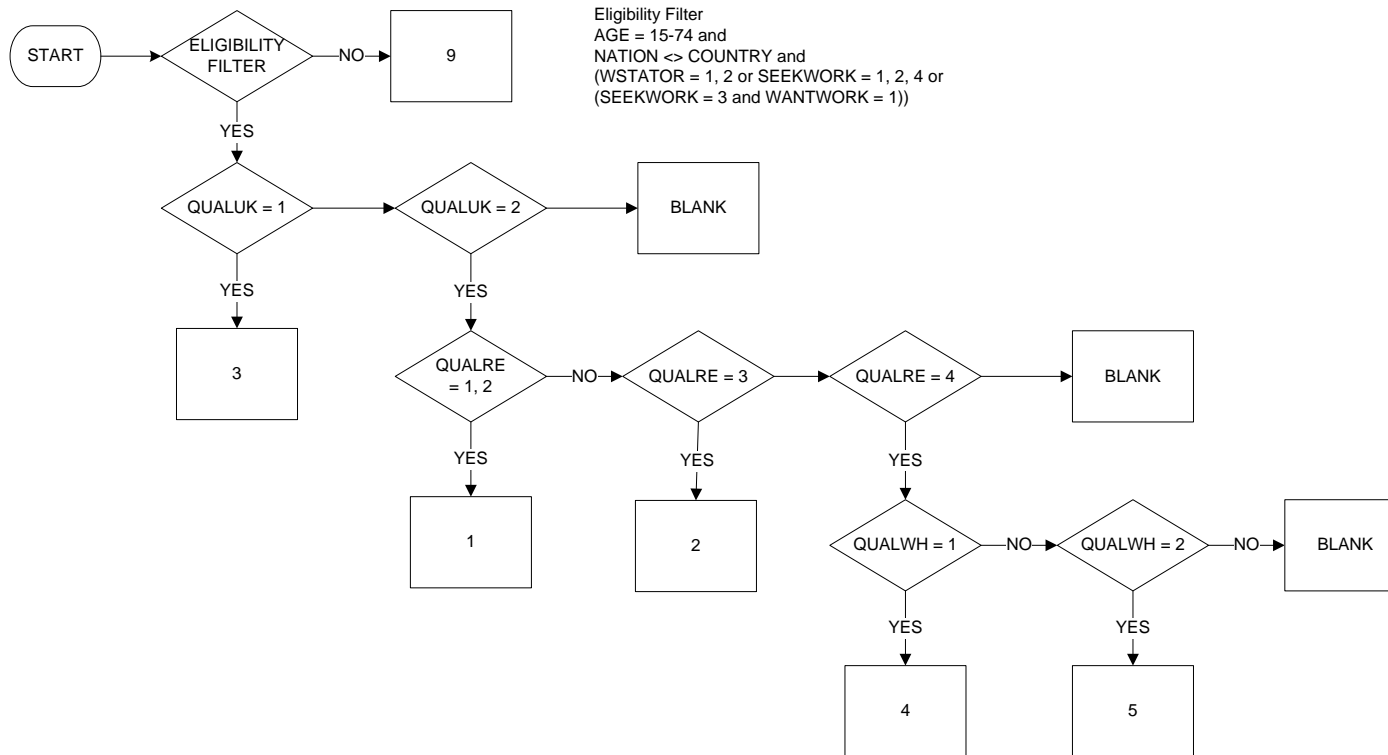

KEY  
 1 Yes, established what qualification equates to  
 2 Yes, but not established what qualification equates to or procedure not yet completed  
 3 No, no need because highest qualification obtained in the host country  
 4 No, no need for reason other reason other than code 3  
 5 No, for other reason  
 9 Not applicable (person aged under 15 or over 74 or not born in the UK and resident for less than one year or not working or not looking for/wanting work)  
 BLANK Unknown / No answer



IMPLANG (ELANGJB): Need to improve host country language skills to get an appropriate job  
Eurostat AHM 2008 Columns 217

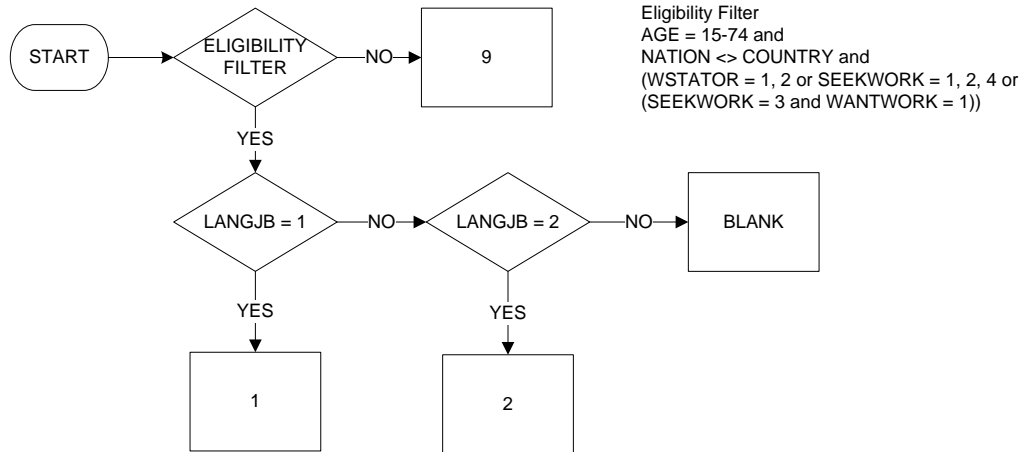

KEY  
1 Yes  
2 No  
9 Not applicable (person aged under 15 or over 74 or not born in the UK and resident for less than one year or not working or not looking for/ wanting work)  
BLANK Unknown / No answer

HELPFING (EHHELP): Main help received in the host country in finding the current job or setting up own business  
Eurostat AHM 2008 Columns 218

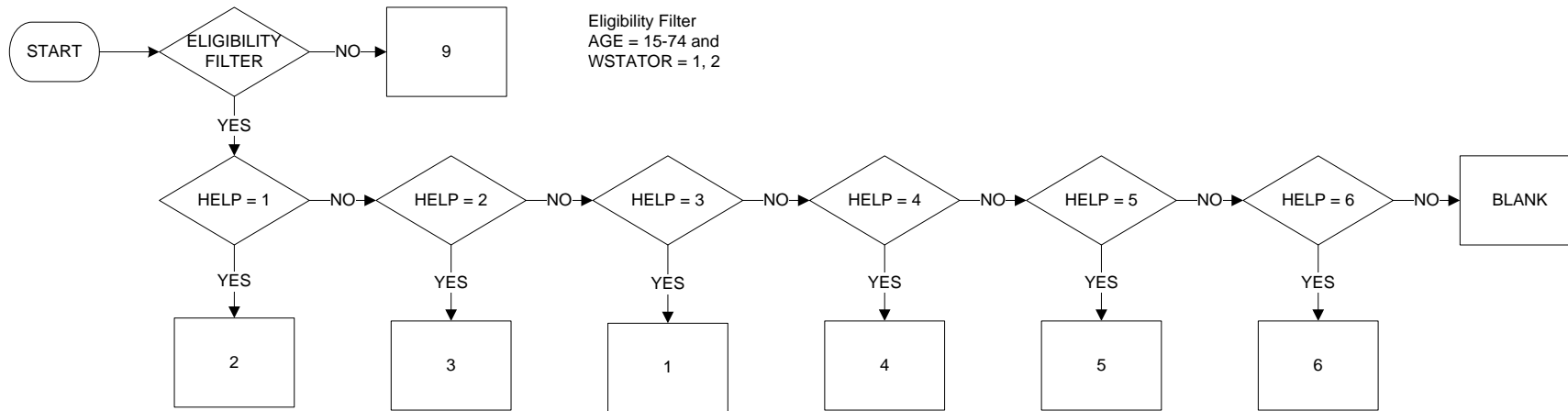

KEY	
1	Relatives/friends
2	Public employment office
3	Private employment service
4	Migrant or ethnic organisation
5	Other
6	None
9	Not applicable (person aged under 15 or over 74 or not in work)
BLANK	Unknown / No answer

SERVINT (ESERV): Use of services for labour market integration in the two years following the last arrival  
Eurostat AHM 2008 Columns 219-220

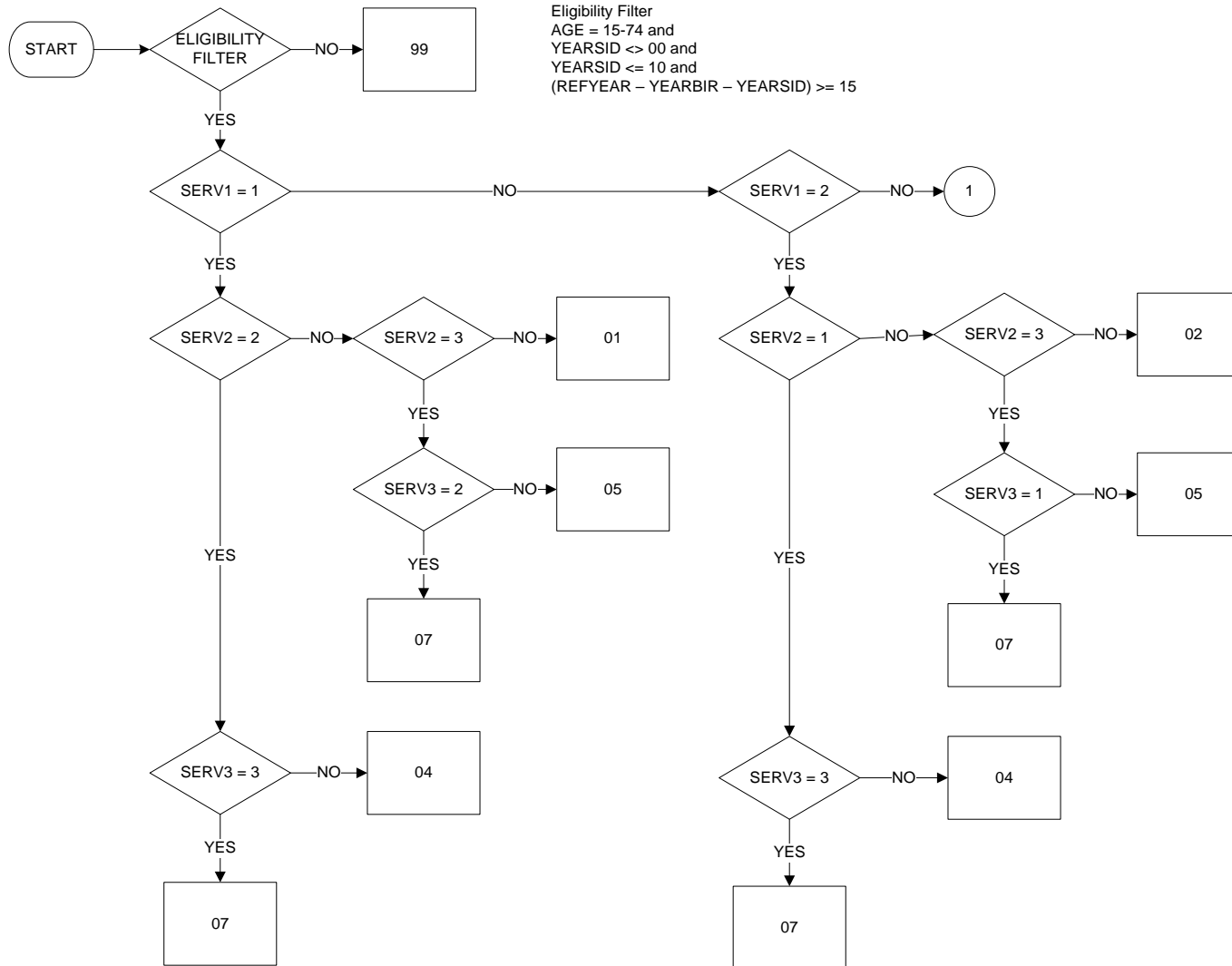

SERVINT (ESERV): Use of services for labour market integration in the two years following the last arrival  
Eurostat AHM 2008 Columns 219-220

Page 2 of 2  
Start date: Apr 2008  
End date: Jun 2008

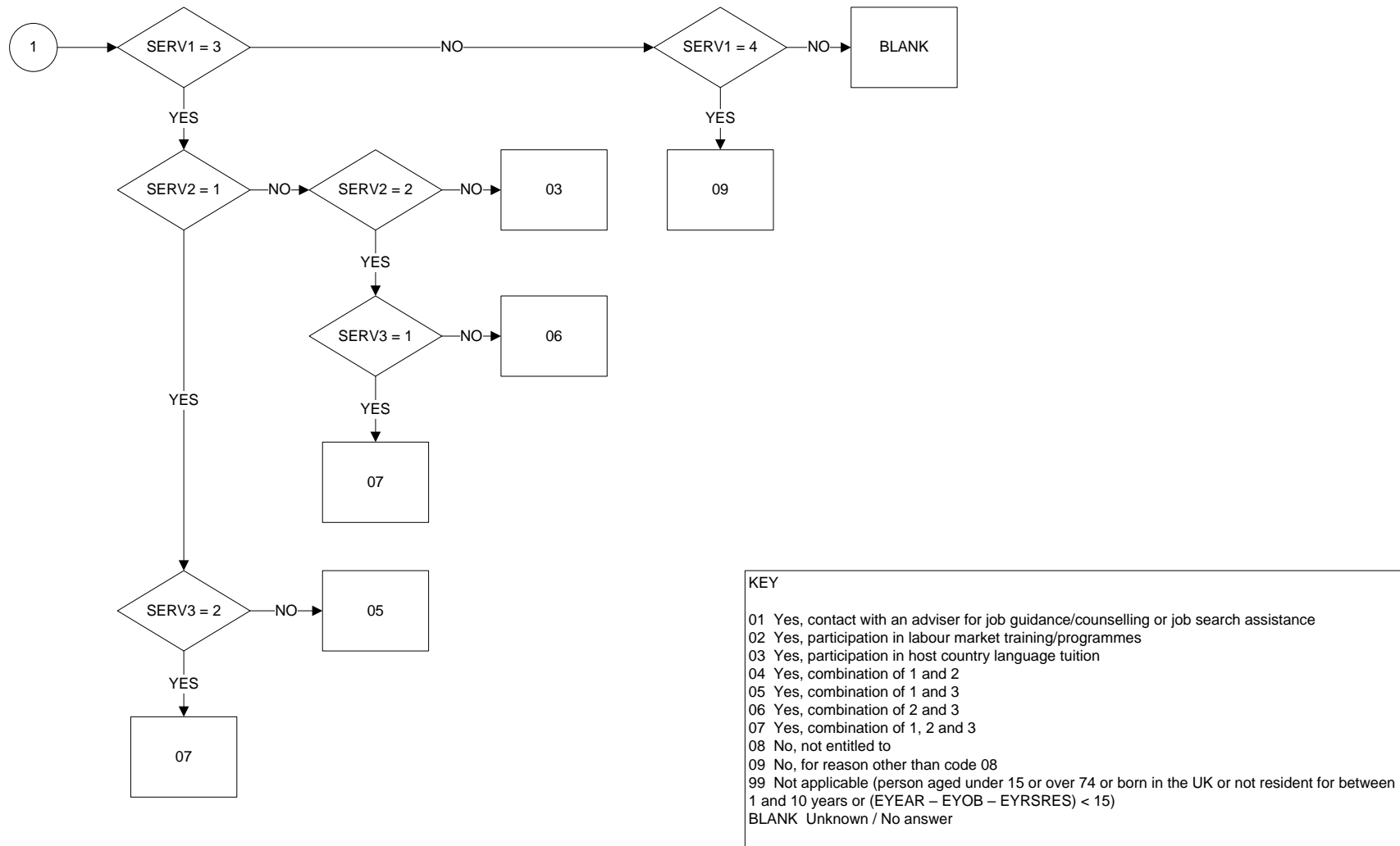

## Explanatory notes for LFS 2008 ad hoc module

### YEARCITI Col 203/206

Year of citizenship acquisition

Citizenship is defined as the particular legal bond between an individual and his/her State, acquired by birth or naturalization, whether by declaration, option, marriage or other means according to the national legislation. Reference should always be made to existing citizenships.

Code 9998: expected in case of break-up of countries, redefinition of borders ...

About dual citizenship: This variable aims to know only about the citizenship of the host country. In case a migrant has a foreign citizenship but also acquired the citizenship of the host country, then the year of citizenship acquisition should be filled. In case a person had a dual citizenship at birth -a foreign and the host country citizenship-, then code 9997 (national at birth) applies.

Note: "National/non national" and "citizen/non citizen" of the host country have exactly the same meaning (legal aspect).

### COBFATH Col 207/208 and COBMOTH Col 209/210

Country of birth of father and mother

Information on the country of birth of parents (father and mother) should be asked for following the same indications given in the core LFS for the variable *Country of birth*. Current borders apply.

For coding, see Annex IV of the LFS explanatory notes. The coding to be used for columns 207/208 and 209/210 shall be the same as for columns 17/18, 21/22, 39/40 and 150/151 of the core LFS (Annex II to Commission Regulation (EC) No 430/2005).

Reference should be made to legal parents. In case of adoption, this recommendation would favour the parents of adoption. Indeed, adopted children are brought up in the host country and live in a family with "native" culture and traditions (perspective of integration).

### TOTRESID Col 211/212

Total number of years of residence in the host country

Years during which person had residence (taking up residence, establishment) in the host country should be taken into account. For example, short visits for tourism or to see family should be excluded.

*For persons with up to one year's residence in total in this Member State, 01 should be coded; between one year and two years, 02; ... (may be revised – see PL comment).*

Only interruptions of residence of more than one year should be considered as an exit of the host country.

For example:

- a person took up residence for 6 months and then went back to his/her country for 2 years and then took up residence again in the host country 2 years ago: the total duration is 2 ½ years and should be coded '03'.
- a person took up residence for 6 months and then went back to his/her country for 9 months and then took up residence again in the host country 5 years ago: the total duration is 6 years and 3 months and should be coded '07'.

Control of the data: C19/20 <= C211/212. In case the last arrival in order to take up residence is also the first one, the same code should be used for C19/20 and C211/212.

## **MIGREAS Col 213**

Reason the person mostly had for migrating (last migration)

Main reason for migrating for the last migration (the most recent) should be recorded.

The individual reason that the person interviewed had for migrating is requested. Different reasons in the same household are expected (e.g. father = employment, mother and child = family).

In case where multiple reasons apply, the main reason should be recorded (spontaneous choice from the person interviewed). The main reason for migrating at the moment of the migration should be recorded.

'Real' reason for migrating (i.e. the one declared by respondents) should be asked for (and not legal reason). All response options should be shown/read out to the interviewed persons for a better harmonisation of the data collected.

- Codes 1, 2 and 3: Entering the country with or without any job perspective has probably not the same impact on the labour market integration. It is important to have this information separately.
- Code 3: Including search for job and including persons who intended to set up own business.
- Code 4: Including trainees, apprentices, interns.
- Code 5: "Forced" migration - Humanitarian migration, including political refugees, asylum seekers, other populations under protection (1951 Geneva Convention on refugee status; Other forms of international protection -temporarily protected, persons in asylum procedure etc.).
- Code 6: It includes accompanying family (e.g. spouse/children) of an entering worker/student, entry of spouse and/or children of a resident. Nuclear family (parents, dependant children) is taken into account as well as other dependant parents and dependant close children relatives (the main criteria is the dependency criteria).
- Code 7: Family formation, creation (marriage).
- Code 8: "Other" should refer to other voluntary migration. E.g. retired persons who came in the host country for their retirement, migrations for the climate, for health reasons, for better medical or health services, less insecurity (outside code 5), "housing" reasons for frontier-worker migrants...

## **DURLIM Col 214**

Whether the duration of the current resident permit/visa/certificate is limited

Codes 1 to 6 are of most interest.

Any kind of authorisation issued by the authorities of a Member State allowing to stay legally in its territory should be taken into account (e.g. residence permit/visa/certificate). Visas often refer to short duration (normally less than 3 months but can be less than 1 year).

The duration refers to the total duration of the authorisation (total length of validity) and not to the duration which is still valid. In case of successive permits, the duration of the current permit should be taken into account.

Coding for situations where residence permits are formally limited but automatically prolonged: the formal situation (limitation) should be taken into account.

EU citizens are often allowed to stay in the MS for unlimited duration (sometimes with the establishment of a certificate). Code 7 should apply in these cases.

Countries should be able to filter out nationals of countries that are free to live in the host country without authorisation for unlimited durations. These cases should be coded 7.

When designing the questionnaire, special care has to be taken due to the sensitivity of the topic.

No recommendation is made at the European level concerning the coding of illegal migrants because of the sensitivity of this issue in some countries. Codes 1 to 6 are of most interest, the MS are free to leave the coding of illegal migrants as their legal statistical rules allow them.

## **RESTRACC Col 215**

Whether current legal access to the labour market is restricted

Codes 1 to 5 have priority on code 6 'Other legal access restrictions'.

Code 6 includes any other kinds of legal restrictions not included in codes 1 to 5 (e.g. geographical restrictions, no access ...), except time restrictions (see C214).

The MS have the possibility to build this variable using information from the core LFS, when feasible and when information is available. E.g. national rules on migrants' legal access to the labour market may be specific for some kinds of population that may be identified using variables from the core LFS. The use of administrative data is also possible to the extent that information can be linked with LFS data.

When designing the questionnaire, special care has to be taken due to the sensitivity of the topic.

No recommendation is made at the European level concerning the coding of illegal migrants or legal migrants working illegally because of the sensitivity of this issue in some countries. The MS are free to leave the coding as their legal statistical rules allow them.

## **ESTQUALI Col 216**

Use of means for establishing what highest qualification equates to in the host country system

"Use of means": all national or international reputable providers of certificates clarifying what qualifications (obtained abroad) equate to in the host country system should be taken into account. E.g. national authorities, professional or university bodies, NARIC (National Academic Recognition Information Centre) ... Such procedures are included whether they are free or not.

"Qualification": including educational qualifications and professional qualifications (vocational/training) - as in the ISCED system.

Code 1: persons obtained a certificate/document establishing what qualification equates to in the host country system.

Code 4: e.g. person does not need such a certificate for the work he/she does/wishes to do ...

Code 5: e.g. person was not aware of any such possibility, person thought it is too complicated, procedure too expensive or time consuming ...

## **IMPLANG Col 217**

Need to improve host country language skills to get an appropriate job

All host nation languages should be taken into account as well as other co-official languages.

Time dimension: current situation applies.

"Appropriate job": type of job person would normally do/search for if language skills were not an issue (i.e. more in line with their qualifications/skills/previous work experiences).

"Need": the need should be the focus and not the willingness.

Code 2 includes:

- Cases where persons' abilities in host country language(s) are good
- Cases where persons' abilities in host country language(s) are not good but where it is not a problem because his/her job is appropriate, or their language skills would, in their view, not affect their ability to get an appropriate job.

## **HELPFING Col 218**

Main help received in the host country in finding the current job or setting up own business

Codes 1 to 5:

- Should only be recorded help provided by persons living/organisations set up IN the host country. E.g. migrants helped by relatives living in the country of origin should be coded 6.
- Migrants that were helped by persons/organisations of the host country but before they arrived in the host country should be included. E.g. a migrant who found his job in the host country before migrating thanks to a relative living in the host country.



Code 6 includes:

- Cases where persons were helped by persons/organisations in the country of origin
- Cases where persons were not helped at all (including those who didn't need any help)

Public employment office: including private organisations mandated by public employment office.

'Other': e.g. employers, business contacts, commune ...

## **SERVINT Col 219/220**

Use of services for labour market integration in the 2 years following the last arrival

“Participation to labour market training/programmes”: including work experience schemes, professional training programmes/integration programmes. Training programmes/measures to assist integration in labour market, including that specific to helping migrants adapt to the labour market in the host country (e.g. participation in work experience schemes, vocational training).

“Participation to host country language tuition”: reading/writing/speaking/understanding.

Public and private services should be included. E.g. services provided by public employment office or by other public services, services provided by associations, employers, Trade Unions ...

"Use of services for labour market integration": e.g. students who were in school without having used services for labour market integration are excluded from codes 1 to 7.

Code 8 'No, not entitled to': means no due to legal barriers.

## **Col 221/226**

Weighting factor for the LFS module 2008

Columns 221/226 should be filled for the countries where the weighting factor for the LFS module 2008 is different to the weighting factor for the core LFS (e.g. proxies allowed in the core LFS but not for the module, specific non-response rate high for the module compared to the core LFS ...).

**Annex I – ISO country classification in the LFS from 2012 onwards**

Code	Country	Group
AD	Andorra	Other European countries
AE	United Arab Emirates	Near and Middle East
AF	Afghanistan	South and South East Asia
AG	Antigua and Barbuda	Central America and Caribbean
AI	Anguilla	Central America and Caribbean
AL	Albania	Other European countries
AM	Armenia	Near and Middle East
AN	Netherlands Antilles	Central America and Caribbean
AO	Angola	Other Africa
AR	Argentina	South America
AT	Austria	European Union
AU	Australia	Australia, Oceania and Other Territories
AW	Aruba	Central America and Caribbean
AZ	Azerbaijan	Near and Middle East
BA	Bosnia Herzegovina	Other European countries
BB	Barbados	Central America and Caribbean
BD	Bangladesh	South and South East Asia
BE	Belgium	European Union
BF	Burkina Faso	Other Africa
BG	Bulgaria	European Union
BH	Bahrain	Near and Middle East
BI	Burundi	Other Africa
BJ	Benin	Other Africa
BL	Saint Barthelemy	Central America and Caribbean
BM	Bermuda	North America
BN	Brunei	South and South East Asia
BO	Bolivia	South America
BR	Brazil	South America
BS	Bahamas	Central America and Caribbean
BT	Bhutan	South and South East Asia
BW	Botswana	Other Africa
BY	Belarus	Other European countries
BZ	Belize	Central America and Caribbean
CA	Canada	North America
CD	Republic Democratic of Congo	Other Africa
CF	Central African Republic	Other Africa
CG	Congo	Other Africa
CH	Switzerland	Candidate and EFTA countries
CI	Ivory Coast	Other Africa
CL	Chile	South America
CM	Cameroon	Other Africa
CN	China	East Asia
CO	Colombia	South America
CR	Costa Rica	Central America and Caribbean
CS	Czechoslovakia <sup>1</sup>	Other European countries
CU	Cuba	Central America and Caribbean
CV	Cape Verde	Other Africa
CY	Cyprus	European Union
CZ	Czech Republic	European Union
DE	Germany	European Union
DJ	Djibouti	Other Africa
DK	Denmark	European Union
DM	Dominica	Central America and Caribbean
DO	Dominican Republic	Central America and Caribbean
DZ	Algeria	North Africa
EC	Ecuador	South America
EE	Estonia	European Union

EG	Egypt	North Africa
EL	Greece	European Union
ER	Eritrea	Other Africa
ES	Spain	European Union
ET	Ethiopia	Other Africa
FI	Finland	European Union
FJ	Fiji	Australia, Oceania and Other Territories
FK	Falkland Islands (Malvinas)	South America
FM	Micronesia	Australia, Oceania and Other Territories
FO	Faroe Islands	Other European countries
FR	France	European Union
GA	Gabon	Other Africa
GD	Grenada	Central America and Caribbean
GE	Georgia	Near and Middle East
GG	Guernsey	Other European countries
GH	Ghana	Other Africa
GI	Gibraltar	Other European countries
GL	Greenland <sup>2</sup>	North America
GM	Gambia	Other Africa
GN	Guinea	Other Africa
GQ	Equatorial Guinea	Other Africa
GT	Guatemala	Central America and Caribbean
GW	Guinea-Bissau	Other Africa
GY	Guyana	South America
HN	Honduras	Central America and Caribbean
HR	Croatia	Candidate and EFTA countries
HT	Haiti	Central America and Caribbean
HU	Hungary	European Union
ID	Indonesia	South and South East Asia
IE	Ireland	European Union
IL	Israel	Near and Middle East
IM	Isle of Man	Other European countries
IN	India	South and South East Asia
IQ	Iraq	Near and Middle East
IR	Iran	Near and Middle East
IS	Iceland	Candidate and EFTA countries
IT	Italy	European Union
JE	Jersey	Other European countries
JM	Jamaica	Central America and Caribbean
JO	Jordan	Near and Middle East
JP	Japan	East Asia
KE	Kenya	Other Africa
KG	Kyrgyzstan	Near and Middle East
KH	Cambodia	South and South East Asia
KI	Kiribati	Australia, Oceania and Other Territories
KM	Comoros	Other Africa
KN	Saint Kitts and Nevis	Central America and Caribbean
KP	Dem. People's Republic of Korea (North)	East Asia
KR	Republic of Korea (South)	East Asia
KW	Kuwait	Near and Middle East
KY	Cayman Islands	Central America and Caribbean
KZ	Kazakhstan	Near and Middle East
LA	Laos	South and South East Asia
LB	Lebanon	Near and Middle East
LC	Saint Lucia	Central America and Caribbean
LI	Liechtenstein	Candidate and EFTA countries
LK	Sri Lanka	South and South East Asia
LR	Liberia	Other Africa
LS	Lesotho	Other Africa
LT	Lithuania	European Union
LV	Latvia	European Union
LY	Libya	North Africa

LU	Luxembourg	European Union
MA	Morocco	North Africa
MC	Monaco	Other European countries
MD	Republic of Moldova	Other European countries
ME	Montenegro	Candidate and EFTA countries
MF	Saint Martin	Central America and Caribbean
MH	Marshall Islands	Australia, Oceania and Other Territories
MK	FYR Macedonia	Candidate and EFTA countries
ML	Mali	Other Africa
MM	Myanmar	South and South East Asia
MN	Mongolia	East Asia
MR	Mauritania	Other Africa
MS	Montserrat	Central America and Caribbean
MT	Malta	European Union
MU	Mauritius	Other Africa
MV	Maldives	South and South East Asia
MW	Malawi	Other Africa
MX	Mexico	Central America and Caribbean
MY	Malaysia	South and South East Asia
MZ	Mozambique	Other Africa
NA	Namibia	Other Africa
NC	New Caledonia	Australia, Oceania and Other Territories
NE	Niger	Other Africa
NG	Nigeria	Other Africa
NI	Nicaragua	Central America and Caribbean
NL	Netherlands	European Union
NN	Recognised non-citizen <sup>3</sup>	-
NO	Norway	Candidate and EFTA countries
NP	Nepal	South and South East Asia
NR	Nauru	Australia, Oceania and Other Territories
NZ	New Zealand	Australia, Oceania and Other Territories
OM	Oman	Near and Middle East
PA	Panama	Central America and Caribbean
PE	Peru	South America
PF	French Polynesia	Australia, Oceania and Other Territories
PG	Papua New Guinea	Australia, Oceania and Other Territories
PH	Philippines	South and South East Asia
PK	Pakistan	South and South East Asia
PL	Poland	European Union
PM	Saint Pierre and Miquelon	North America
PN	Pitcairn	Australia, Oceania and Other Territories
PR	Puerto Rico <sup>4</sup>	Central America and Caribbean
PS	Palestine <sup>4</sup>	Near and Middle East
PT	Portugal	European Union
PW	Palau	Australia, Oceania and Other Territories
PY	Paraguay	South America
QA	Qatar	Near and Middle East
RO	Romania	European Union
RS	Serbia	Other European countries
RU	Russian Federation	Other European countries
RW	Rwanda	Other Africa
SA	Saudi Arabia	Near and Middle East
SB	Soloman Islands	Australia, Oceania and Other Territories
SC	Seychelles	Other Africa
SD	Sudan	Other Africa
SE	Sweden	European Union
SG	Singapore	South and South East Asia
SH	Saint Helena	Other Africa
SI	Slovenia	European Union
SK	Slovak Republic	European Union
SL	Sierra Leone	Other Africa
SM	San Marino	Other European countries

SN	Senegal	Other Africa
SO	Somalia	Other Africa
SR	Suriname	South America
SS	South Sudan	Other Africa
ST	Sao Tome and Principe	Other Africa
SU	Soviet Union <sup>1</sup>	Other European countries
SV	El Salvador	Central America and Caribbean
SY	Syria	Near and Middle East
SZ	Swaziland	Other Africa
TC	Turks and Caicos Islands	Central America and Caribbean
TD	Chad	Other Africa
TF	French Southern Territories	South America
TG	Togo	Other Africa
TH	Thailand	South and South East Asia
TJ	Tajikistan	Near and Middle East
TL	East Timor	South and South East Asia
TM	Turkmenistan	Near and Middle East
TN	Tunisia	North Africa
TO	Tonga	Australia, Oceania and Other Territories
TR	Turkey	Candidate and EFTA countries
TT	Trinidad and Tobago	Central America and Caribbean
TU	Tunisia	North Africa
TV	Tuvalu	Australia, Oceania and Other Territories
TW	Taiwan	East Asia
TZ	Tanzania	Other Africa
UA	Ukraine	Other European countries
UG	Uganda	Other Africa
UK	United Kingdom	European Union
US	United States of America	North America
UY	Uruguay	South America
UZ	Uzbekistan	Near and Middle East
VA	Vatican City	Other European countries
VC	Saint Vincent and the Grenadines	Central America and Caribbean
VE	Venezuela	South America
VG	British Virgin Islands	Central America and Caribbean
VN	Vietnam	South and South East Asia
VU	Vanuatu	Australia, Oceania and Other Territories
WF	Wallis and Futuna	Australia, Oceania and Other Territories
WS	Samoa	Australia, Oceania and Other Territories
XK	Kosovo (UNSCR1244)	Other European countries
YE	Yemen	Near and Middle East
YT	Mayotte	Other Africa
YU	Yugoslavia <sup>1</sup>	Other European countries
ZA	South Africa	Other Africa
ZM	Zambia	Other Africa
ZW	Zimbabwe	Other Africa
05	-	North Africa
06	-	Other Africa
07	-	North America
08	-	Central America and Caribbean
09	-	South America
10	-	East Asia
11	-	Near and Middle East
12	-	South and South East Asia
13	-	Australia, Oceania and Other Territories
14	-	Other + Stateless

### Notes

- <sup>1</sup> Country of Birth only
- <sup>2</sup> Country of Birth, Work and Residence-one-year-ago only
- <sup>3</sup> Nationality only
- <sup>4</sup> Not in census list

**Annex II - CRY07 to ISO country look-up (including 2014 amendments)**

<b>CRY07</b>		<b>ILO Country code</b>	
4	Afghanistan	AF	Afghanistan
8	Albania	AL	Albania
10	Antarctica	14	Other + Stateless
12	Algeria	DZ	Algeria
16	American Samoa	13	Australia, Oceania and Other Territories
20	Andorra	AD	Andorra
24	Angola	AO	Angola
28	Antigua and Barbuda	AG	Antigua and Barbuda
31	Azerbaijan	AZ	Azerbaijan
32	Argentina	AR	Argentina
36	Australia	AU	Australia
40	Austria	AT	Austria
44	Bahamas, The	BS	Bahamas
48	Bahrain	BH	Bahrain
50	Bangladesh	BD	Bangladesh
51	Armenia	AM	Armenia
52	Barbados	BB	Barbados
56	Belgium	BE	Belgium
60	Bermuda	BM	Bermuda
64	Bhutan	BT	Bhutan
68	Bolivia	BO	Bolivia
70	Bosnia and Herzegovina	BA	Bosnia Herzegovina
72	Botswana	BW	Botswana
74	Bouvet Island	14	Other + Stateless
76	Brazil	BR	Brazil
84	Belize	BZ	Belize
86	British Indian Ocean Territory	13	Australia, Oceania and Other Territories
90	Solomon Islands	SB	Soloman Islands
92	British Virgin Islands	08	Central America and Caribbean
96	Brunei	BN	Brunei
100	Bulgaria	BG	Bulgaria
104	Burma	MM	Myanmar
108	Burundi	BI	Burundi
112	Belarus	BY	Belarus
116	Cambodia	KH	Cambodia
120	Cameroon	CM	Cameroon
124	Canada	CA	Canada
132	Cape Verde	CV	Cape Verde
136	Cayman Islands	08	Central America and Caribbean
140	Central African Republic	CF	Central African Republic
144	Sri Lanka	LK	Sri Lanka
148	Chad	TD	Chad
152	Chile	CL	Chile
156	China	CN	China
158	China (Taiwan)	TW	Taiwan
162	Christmas Island	12	South and South East Asia
166	Cocos (Keeling) Islands	12	South and South East Asia
170	Colombia	CO	Colombia
174	Comoros	06	Other Africa
175	Mayotte	06	Other Africa
178	Congo	CG	Congo
180	Congo (Democratic Republic)	CD	Republic Democratic of Congo
184	Cook Islands	13	Australia, Oceania and Other Territories
188	Costa Rica	CR	Costa Rica
191	Croatia	HR	Croatia
192	Cuba	CU	Cuba
203	Czech Republic	CZ	Czech Republic
204	Benin	BJ	Benin

**CRY07**

208	Denmark
212	Dominica
214	Dominican Republic
218	Ecuador
222	El Salvador
226	Equatorial Guinea
231	Ethiopia
232	Eritrea
233	Estonia
234	Faroe Islands
238	Falkland Islands
239	South Georgia and South Sandwich Island
242	Fiji
246	Finland
248	Aland Islands
250	France
254	French Guiana
258	French Polynesia
260	French Southern Territories
262	Djibouti
266	Gabon
268	Georgia
270	Gambia, The
275	West Bank (Including East Jerusalem)
276	Germany
288	Ghana
292	Gibraltar
296	Kiribati
300	Greece
304	Greenland
308	Grenada
312	Guadeloupe
316	Guam
320	Guatemala
324	Guinea
328	Guyana
332	Haiti
334	Heard Island and McDonald Islands
336	Vatican City
340	Honduras
344	Hong Kong (Special Administrative Region)
348	Hungary
352	Iceland
356	India
360	Indonesia
364	Iran
368	Iraq
372	Ireland
376	Israel
380	Italy
384	Ivory Coast
388	Jamaica
392	Japan
398	Kazakhstan
400	Jordan
404	Kenya
408	Korea (North)
410	Korea (South)

**ILO Country code**

DK	Denmark
DM	Dominica
DO	Dominican Republic
EC	Ecuador
SV	El Salvador
GQ	Equatorial Guinea
ET	Ethiopia
ER	Eritrea
EE	Estonia
14	Other + Stateless
09	South America
09	South America
FJ	Fiji
FI	Finland
FI	Finland
FR	France
09	South America
PF	French Polynesia
14	Other + Stateless
DJ	Djibouti
GA	Gabon
GE	Georgia
GM	Gambia
PS	Palestine
DE	Germany
GH	Ghana
GI	Gibraltar
13	Australia, Oceania and Other Territories
EL	Greece
GL	Greenland
GD	Grenada
08	Central America and Caribbean
13	Australia, Oceania and Other Territories
GT	Guatemala
GN	Guinea
GY	Guyana
HT	Haiti
14	Other + Stateless
VA	Vatican City
HN	Honduras
CN	China
HU	Hungary
IS	Iceland
IN	India
ID	Indonesia
IR	Iran
IQ	Iraq
IE	Ireland
IL	Israel
IT	Italy
CI	Ivory Coast
JM	Jamaica
JP	Japan
KZ	Kazakhstan
JO	Jordan
KE	Kenya
KP	Dem. People's Republic of Korea (North)
KR	Republic of Korea (South)

**CRY07**

414	Kuwait
417	Kyrgyzstan
418	Laos
422	Lebanon
426	Lesotho
428	Latvia
430	Liberia
434	Libya
438	Liechtenstein
440	Lithuania
442	Luxembourg
446	Macao (Special Administrative Region)
450	Madagascar
454	Malawi
458	Malaysia
462	Maldives
466	Mali
470	Malta
474	Martinique
478	Mauritania
480	Mauritius
484	Mexico
492	Monaco
496	Mongolia
498	Moldova
499	Montenegro
500	Montserrat
504	Morocco
508	Mozambique
512	Oman
516	Namibia
520	Nauru
524	Nepal
528	Netherlands
530	Netherlands Antilles
531	Curacao
533	Aruba
534	St Maarten (Dutch part)
535	Bonaire, St Eustatius and Saba
540	New Caledonia
548	Vanuatu
554	New Zealand
558	Nicaragua
562	Niger
566	Nigeria
570	Niue
574	Norfolk Island
578	Norway
580	Northern Mariana Islands
581	US Minor Outlying Islands
583	Micronesia
584	Marshall Islands
585	Palau
586	Pakistan
591	Panama
598	Papua New Guinea
600	Paraguay
604	Peru

**ILO Country code**

KW	Kuwait
KG	Kyrgyzstan
LA	Laos
LB	Lebanon
LS	Lesotho
LV	Latvia
LR	Liberia
LY	Libya
LI	Liechtenstein
LT	Lithuania
LU	Luxembourg
CN	China
MG	Madagascar
MW	Malawi
MY	Malaysia
MV	Maldives
ML	Mali
MT	Malta
08	Central America and Caribbean
MR	Mauritania
MU	Mauritius
MX	Mexico
MC	Monaco
MN	Mongolia
MD	Republic of Moldova
ME	Montenegro
08	Central America and Caribbean
MA	Morocco
MZ	Mozambique
OM	Oman
NA	Namibia
13	Australia, Oceania and Other Territories
NP	Nepal
NL	Netherlands
AN	Netherlands Antilles
08	Central America and Caribbean
08	Central America and Caribbean
08	Central America and Caribbean
08	Central America and Caribbean
NC	New Caledonia
VU	Vanuatu
NZ	New Zealand
NI	Nicaragua
NE	Niger
NG	Nigeria
13	Australia, Oceania and Other Territories
13	Australia, Oceania and Other Territories
NO	Norway
13	Australia, Oceania and Other Territories
US	United States of America
FM	Micronesia
13	Australia, Oceania and Other Territories
13	Australia, Oceania and Other Territories
PK	Pakistan
PA	Panama
PG	Papua New Guinea
PY	Paraguay
PE	Peru



**CRY07**

608	Philippines
612	Pitcairn, Henderson, Ducie and Oeno Isla
616	Poland
620	Portugal
624	Guinea-Bissau
626	East Timor
630	Puerto Rico
634	Qatar
638	Reunion
642	Romania
643	Russia
646	Rwanda
652	St Barthelemy
654	St Helena
659	St Kitts and Nevis
660	Anguilla
662	St Lucia
663	St Martin
666	St Pierre and Miquelon
670	St Vincent and The Grenadines
674	San Marino
678	Sao Tome and Principe
682	Saudi Arabia
686	Senegal
688	Serbia
690	Seychelles
694	Sierra Leone
702	Singapore
703	Slovakia
704	Vietnam
705	Slovenia
706	Somalia
710	South Africa
716	Zimbabwe
728	South Sudan
729	Sudan
732	Western Sahara
740	Surinam
744	Svalbard and Jan Mayen
748	Swaziland
752	Sweden
756	Switzerland
760	Syria
762	Tajikistan
764	Thailand
768	Togo
772	Tokelau
776	Tonga
780	Trinidad and Tobago
784	United Arab Emirates
788	Tunisia
792	Turkey
795	Turkmenistan
796	Turks And Caicos Islands
798	Tuvalu
800	Uganda
804	Ukraine
807	Macedonia
818	Egypt

**ILO Country code**

PH	Philippines
13	Australia, Oceania and Other Territories
PL	Poland
PT	Portugal
GW	Guinea-Bissau
TL	East Timor
PR	Puerto Rico
QA	Qatar
FR	France
RO	Romania
RU	Russian Federation
RW	Rwanda
BL	Saint Barthelemy
06	Other Africa
08	Central America and Caribbean
08	Central America and Caribbean
08	Central America and Caribbean
MF	St Martin
PM	Saint Pierre and Miquelon
08	Central America and Caribbean
SM	San Marino
ST	Sao Tome and Principe
SA	Saudi Arabia
SN	Senegal
RS	Serbia
SC	Seychelles
SL	Sierra Leone
SG	Singapore
SK	Slovak Republic
VN	Vietnam
SI	Slovenia
SO	Somalia
ZA	South Africa
ZW	Zimbabwe
SS	South Sudan
SD	Sudan
05	North Africa
SR	Suriname
14	Other + Stateless
SZ	Swaziland
SE	Sweden
CH	Switzerland
SY	Syria
TJ	Tajikistan
TH	Thailand
TG	Togo
13	Australia, Oceania and Other Territories
13	Australia, Oceania and Other Territories
TT	Trinidad and Tobago
AE	United Arab Emirates
TN	Tunisia
TR	Turkey
TM	Turkmenistan
08	Central America and Caribbean
13	Australia, Oceania and Other Territories
UG	Uganda
UA	Ukraine
MK	FYR Macedonia
EG	Egypt

**CRY07**

831	Guernsey
832	Jersey
833	Isle of Man
834	Tanzania
840	United States
850	United States Virgin Islands
854	Burkina
858	Uruguay
860	Uzbekistan
862	Venezuela
876	Wallis and Futuna
882	Samoa
882	Samoa
887	Yemen
891	Kosova and Metohia
894	Zambia
901	Cyprus (European Union)
902	Cyprus (Non-European Union)
903	Cyprus (Not Otherwise Specified)
911	Spain (Except Canary Islands)
912	Canary Islands
913	Spain NOS
951	Kosovo
971	Czechoslovakia NOS
972	USSR NOS
973	Yugoslavia NOS
974	Serbia And Montenegro NOS
981	Europe NOS
982	Africa NOS
983	Middle East NOS
984	Asia (Except Middle East) NOS
985	North America NOS
986	Central America NOS
987	South America NOS
988	Caribbean NOS
989	Antartica And Oceania NOS
991	At Sea
992	In The Air

**ILO Country code**

GG	Guernsey
JE	Jersey
IM	Isle of Man
TZ	Tanzania
US	United States of America
08	Central America and Caribbean
BF	Burkina Faso
UY	Uruguay
UZ	Uzbekistan
VE	Venezuela
13	Australia, Oceania and Other Territories
13	Australia, Oceania and Other Territories
13	Australia, Oceania and Other Territories
YE	Yemen
XK	Kosovo (UNSCR1244)
ZM	Zambia
CY	Cyprus
CY	Cyprus
CY	Cyprus
ES	Spain
ES	Spain
ES	Spain
XK	Kosovo (UNSCR1244)
CZ	Czech Republic
RU	Russian Federation
04	Other Europe
04	Other Europe
14	Other + Stateless
06	Other Africa
11	Near and Middle East
12	South and South East Asia
07	North America
08	Central America and Caribbean
09	South America
08	Central America and Caribbean
14	Other + Stateless
14	Other + Stateless
14	Other + Stateless

**Annex III (a) – SOC2000 to ISCO-88 (COM) look-up**

SOC2000		ISCO88	
1111	Senior officials in national gov	1110	Legislators and senior government officials
1112	Directors & chief execs of maj orgs	1210	Directors and chief executives
1113	Senior officials in local gov	1110	Legislators and senior government officials
1114	Sen. officials spec interest orgs	1140	Senior officials of special-interest organisations
1121	Prod. works & maintenance managers	1222	Production and operations managers in manufacturing
		1312	Managers of small enterprises in manufacturing
1122	Managers in construction	1223	Production and operations managers in construction
		1313	Managers of small enterprises in construction
1123	Managers in mining and energy	1222	Production and operations managers in manufacturing
1131	Financial managers & chartered secs	1231	Finance and administration managers
1132	Marketing and sales managers	1233	Sales and marketing managers
1133	Purchasing managers	1235	Supply and distribution managers
1134	Advertising & public rel managers	1234	Advertising and public relations managers
1135	Pers training & ind rel mngers	1232	Personnel and industrial relations managers
1136	Info & communication technol mngers	1236	Computing services managers
1137	Research and development managers	1237	Research and development managers
1141	Quality assurance managers	1239	Other specialist managers not elsewhere classified
1142	Customer care managers	1239	Other specialist managers not elsewhere classified
1151	Financial institution managers	1227	Production and operations managers in business services enterprises
		1317	Managers of small enterprises of business services enterprises
1152	Office managers	1231	Finance and administration managers
1161	Transport and distribution managers	1226	Production and operations managers in transport, storage, comms
		1316	Managers of small enterprises in transport, storage and comms
1162	Storage and warehouse managers	1226	Production and operations managers in transport, storage, comms
		1316	Managers of small enterprises in transport, storage and comms
1163	Retail and wholesale managers	1224	Production and operations managers in wholesale and retail trade
		1314	Managers of small enterprises in wholesale and retail trade
1171	Officers in armed forces	0100	Armed Forces
1172	Police officers (inspectrs & above)	3450	Police inspectors and detectives
1173	Snr officers fire, amb, prson et al	1229	Production and operations managers not elsewhere classified
1174	Security managers	1239	Other specialist managers not elsewhere classified
1181	Hospital and health service mngers	1229	Production and operations managers not elsewhere classified
1182	Pharmacy managers	1229	Production and operations managers not elsewhere classified
		1319	Managers of small enterprises not elsewhere classified
1183	Healthcare practice managers	1229	Production and operations managers not elsewhere classified
		1319	Managers of small enterprises not elsewhere classified
1184	Social services managers	1229	Production and operations managers not elsewhere classified
1185	Residential and day care managers	1228	Production and operations managers in personal care, cleaning etc
		1318	Managers of small enterprises in personal care, cleaning etc
1211	Farm managers	1221	Production, operations managers in agriculture, hunting, forestry, fishing
		1311	Managers of small enterprises in agriculture, hunting, forestry, fishing
1212	Natural environ & cons managers	1221	Production, operations managers in agriculture, hunting, forestry, fishing
		1311	Managers of small enterprises in agriculture, hunting, forestry, fishing
1219	Mngr anml hsbndry, frst, fish nec.	1221	Production, operations managers in agriculture, hunting, forestry, fishing
		1311	Managers of small enterprises in agriculture, hunting, forestry, fishing
1221	Hotel and accommodation managers	1225	Production and operations managers in restaurants and hotels
		1315	Managers of small enterprises of restaurants and hotels
1222	Conference and exhibition managers	1227	Production and operations managers in business services enterprises
		1317	Managers of small enterprises of business services enterprises
1223	Restaurant and catering managers	1225	Production and operations managers in restaurants and hotels
		1315	Managers of small enterprises of restaurants and hotels
1224	Publicans & managrs licensed prmises	1225	Production and operations managers in restaurants and hotels
		1315	Managers of small enterprises of restaurants and hotels
1225	Leisure and sports managers	1229	Production and operations managers not elsewhere classified
		1319	Managers of small enterprises not elsewhere classified
1226	Travel agency managers	1226	Production and operations managers in transport, storage and comms
		1316	Managers of small enterprises in transport, storage and comms

SOC2000		ISCO88	
1231	Property, housing and land managers	1227	Production and operations managers in business services enterprises
		1317	Managers of small enterprises of business services enterprises
1232	Garage managers and proprietors	1224	Production and operations managers in wholesale and retail trade
		1314	Managers of small enterprises in wholesale and retail trade
1233	Hairdres & beauty slon mngr & props	1228	Production and operations managers in personal care, cleaning etc
		1318	Managers of small enterprises in personal care, cleaning etc
1234	Shopkprs, wholesale & retail deals	1314	Managers of small enterprises in wholesale and retail trade
		1229	Production and operations managers not elsewhere classified
1235	Recyc and refuse disposal managers	1319	Managers of small enterprises not elsewhere classified
		1229	Production and operations managers not elsewhere classified
1239	Mngers and prop. In other srvcs NEC	1319	Managers of small enterprises not elsewhere classified
2111	Chemists	2113	Chemists
2112	Bio scientists and biochemists	2211	Biologists, botanists, zoologists and related professionals
2113	Physts, geologists & meteorologists	2110	Physicists, chemists and related professionals
2121	Civil engineers	2142	Civil engineers
2122	Mechanical engineers	2145	Mechanical engineers
2123	Electrical engineers	2143	Electrical engineers
2124	Electronics engineers	2144	Electronics and telecommunications engineers
2125	Chemical engineers	2146	Chemical engineers
2126	Design and development engineers	2149	Architects, engineers and related professionals NEC
2127	Production and process engineers	2149	Architects, engineers and related professionals NEC
2128	Planning and qlty control engineers	2149	Architects, engineers and related professionals NEC
2129	Engineering professionals n.e.c.	2149	Architects, engineers and related professionals NEC
2131	IT strategy and planning prfsnals	2130	Computing professionals
2132	Software professionals	2130	Computing professionals
2211	Medical practitioners	2221	Medical doctors
2212	Psychologists	2445	Psychologists
2213	Pharmacists & pharmacologists	2224	Pharmacists
2214	Ophthalmic opticians	2229	Health professionals (except nursing) NEC
2215	Dental practitioners	2222	Dentists
2216	Veterinarians	2223	Veterinarians
2311	Higher educ teaching prfsnals	2310	College, university and higher education teaching professionals
2312	Further educ teaching prfsnals	2310	College, university and higher education teaching professionals
2313	educ officers,school inspectrs	2352	School inspectors
2314	Secondary eductn teaching prfsnals	2320	Secondary education teaching professionals
2315	Prim & nurs eductn teaching profs	2330	Primary and pre-primary education teaching professionals
2316	Spec needs educ teaching profs	2340	Special education teaching professionals
2317	Registrs & sen admins ed establish	2359	Other teaching professionals NEC
2319	Teaching professionals n.e.c.	2359	Other teaching professionals NEC
2321	Scientific researchers	2110	Physicists, chemists and related professionals
2322	Social science researchers	2440	Social science and related professionals
2329	Researchers n.e.c.	2310	College, university and higher education teaching professionals
2411	Solic & lawyers, judges & coroners	2420	Legal professionals
2419	Legal professionals n.e.c.	2429	Legal professionals NEC
2421	Chartered and certified accountants	2411	Accountants
2422	Management accountants	2411	Accountants
2423	Mngmnt cons, actuar, econs & statn	2419	Business professionals NEC
2431	Architects	2141	Architects, town and traffic planners
2432	Town planners	2141	Architects, town and traffic planners
2433	Quantity surveyors	2148	Cartographers and surveyors
2434	Chartrd surveyors (not qntity surv)	2148	Cartographers and surveyors
2441	Public service administrative profs	2470	Public service administrative professionals
2442	Social workers	2446	Social work professionals
2443	Probation officers	2446	Social work professionals
2444	Clergy	2460	Religious professionals
2451	Librarians	2432	Librarians and related information professionals
2452	Archivists and curators	2431	Archivists and curators
3111	Laboratory technicians	3111	Chemical and physical science technicians
3112	Electrical & electronic technicians	3114	Electronics and telecommunications engineering technicians

SOC2000		ISCO88	
3113	Engineering technicians	3110	Physical and engineering science technicians
3114	Build & civil eng technicians	3112	Civil engineering technicians
3115	Quality assurance technicians	3119	Physical and engineering science technicians NEC
3119	Science & eng technicians n.e.c.	3119	Physical and engineering science technicians NEC
3121	Archt technols & town plan technics	3119	Physical and engineering science technicians NEC
3122	Draughtspersons	3118	Draughtspersons
3123	Building inspectors	3151	Building and fire inspectors
3131	IT operations technicians	3120	Computer associate professionals
3132	IT user support technicians	3120	Computer associate professionals
3211	Nurses	3231	Nursing associate professionals
3212	Midwives	3232	Midwifery associate professionals
3213	Paramedics	3221	Medical assistants
3214	Medical radiographers	3133	Medical equipment operators
3215	Chiroprpodists	3226	Physiotherapists and related associate professionals
3216	Dispensing opticians	3224	Optometrists and opticians
3217	Pharmaceutical dispensers	3228	Pharmaceutical assistants
3218	Medical and dental technicians	3220	Health associate professionals (except nursing)
3221	Physiotherapists	3226	Physiotherapists and related associate professionals
3222	Occupational therapists	3226	Physiotherapists and related associate professionals
3223	Speech and language therapists	3226	Physiotherapists and related associate professionals
3229	Therapists n.e.c.	3226	Physiotherapists and related associate professionals
3231	Youth and community workers	3460	Social work associate professionals
3232	Housing and welfare officers	3460	Social work associate professionals
3311	NCOs and other ranks	0100	Armed Forces
3312	Police offcirs (sergeant and below)	5162	Police officers
3313	Fire serv off (leading off & below)	5161	Fire-fighters
3314	Prison serv off (below princ off)	5163	Prison guards
3319	Protective servcs assoc prfsnls NEC	5169	Protective services workers NEC
3411	Artists	2452	Sculptors, painters and related artists
3412	Authors, writers	2451	Authors, journalists and other writers
3413	Actors, entertainers	3470	Artistic, entertainment and sports associate professionals
3414	Dancers and choreographers	3473	Street, night-club and related musicians, singers and dancers
3415	Musicians	3473	Street, night-club and related musicians, singers and dancers
3416	Arts offcirs, prdcers and directors	2455	Film, stage and related actors and directors
3421	Graphic designers	3471	Decorators and commercial designers
3422	Product, clothing & related dsgners	3471	Decorators and commercial designers
3431	Journalists, newsprr & period eds	2451	Authors, journalists and other writers
3432	Broadcasting associate prfssnals	3472	Radio, television and other announcers
3433	Public relations officers	3419	Finance and sales associate professionals NEC
3434	Photo. & audio-visual equip operats	3131	Photographers and image and sound recording equipment operators
3441	Sports players	3475	Athletes, sports persons and related associate professionals
3442	Sports coaches, instruc & officials	3475	Athletes, sports persons and related associate professionals
3443	Fitness instructors	3475	Athletes, sports persons and related associate professionals
3449	Sports and fitness occupations nec.	3475	Athletes, sports persons and related associate professionals
3511	Air traffic controllers	3144	Air traffic controllers
3512	Aircraft pilots and flight engins	3143	Aircraft pilots and related associate professionals
3513	Ship and hovercraft officers	3142	Ships' deck officers and pilots
3514	Train drivers	8311	Locomotive engine drivers
3520	Legal associate professionals	3432	Legal and related business associate professionals
3531	Estimators, valuers and assessors	3417	Appraisers, valuers and auctioneers
3532	Brokers	3411	Securities and finance dealers and brokers
3533	Insurance underwriters	3412	Insurance representatives
3534	Fin. & invest. analyst & advisers	3419	Finance and sales associate professionals NEC
3535	Taxation experts	3442	Government tax and excise officials
3536	Importers, exporters	3422	Clearing and forwarding agents
3537	Financial and accounting techs	3433	Bookkeepers
3539	Business & related assoc profs nec.	3419	Finance and sales associate professionals NEC
3541	Buyers and purchasing officers	3416	Buyers
3542	Sales representatives	3415	Technical and commercial sales representatives

SOC2000		ISCO88	
3542	Sales representatives	3415	Technical and commercial sales representatives
3543	Marketing associate professionals	3419	Finance and sales associate professionals NEC
3544	Estate agents, auctioneers	3413	Estate agents
3551	Conservat & environ protection offs	3210	Life science technicians and related associate professionals
3552	Countryside and park rangers	3210	Life science technicians and related associate professionals
3561	Public serv associate professionals	3449	Customs, tax and related government associate professionals NEC
3562	Personnel & ind relations offs	2412	Personnel and careers professionals
3563	Vocatn & indust trainrs & instrctrs	3340	Other teaching associate professionals
3564	Car. advis & vocation guidnce spcils	2412	Personnel and careers professionals
3565	Inspcts fact, utils & trdng stndrds	3152	Safety, health and quality inspectors
3566	Statutory examiners	3152	Safety, health and quality inspectors
3567	Occupl hygnists & health sfty offs	3152	Safety, health and quality inspectors
3568	Environmental health officers	3152	Safety, health and quality inspectors
4111	Civil Service executive officers	4190	Other office clerks
4112	Civil Serv admin offcrs and assists	4190	Other office clerks
4113	Local gov clerical offs & assists	4190	Other office clerks
4114	Officers non-gov organisations	4190	Other office clerks
4121	Credit controllers	4120	Numerical clerks
4122	Accnts wages clerk, bookkeeper	4120	Numerical clerks
4123	Counter clerks	4210	Cashiers, tellers and related clerks
4131	Filing & othr recrds assists & clrks	4141	Library and filing clerks
4132	Pensions and insurance clrks	4190	Other office clerks
4133	Stock control clerks	4131	Stock clerks
4134	Transport and distribution clerks	4133	Transport clerks
4135	Library assistants & clerks	4141	Library and filing clerks
4136	Database assistants & clerks	4113	Data entry operators
4137	Market research interviewers	4190	Other office clerks
4141	Telephonists	4223	Telephone switchboard operators
4142	Communication operators	4223	Telephone switchboard operators
4150	General office assistants or clerks	4190	Other office clerks
4211	Medical secretaries	4115	Secretaries
4212	Legal secretaries	4115	Secretaries
4213	School secretaries	4115	Secretaries
4214	Company secretaries	4115	Secretaries
4215	Personal assists & othr secretaries	4115	Secretaries
4216	Receptionists	4222	Receptionists and information clerks
4217	Typists	4110	Secretaries and keyboard-operating clerks
5111	Farmers	6130	Crop and animal producers
5112	Horticultural trades	6112	Gardeners, horticultural and nursery growers
5113	Gardeners and grounds(women)	6112	Gardeners, horticultural and nursery growers
5119	Agricult and fishing trades n.e.c.	6150	Fishery workers, hunters and trappers
5211	Smiths and forge workers	7221	Blacksmiths, hammer-smiths and forging-press workers
5212	Moulders, core makers, die casters	7211	Metal moulders and coremakers
5213	Sheet metal workers	7213	Sheet-metal workers
5214	Mtl plate wrkrs, shipwrig, riveters	7214	Structural-metal preparers and erectors
5215	Welding trades	7212	Welders and flame cutters
5216	Pipe fitters	7136	Plumbers and pipe fitters
5221	Metal mach setter & setter-operator	7223	Machine-tool setters and setter-operators
5222	Tool mkrs, tool fters & markers-out	7222	Tool-makers and related workers
5223	Mtl working prod & maintnce fitter	7230	Machinery mechanics and fitters
5224	Prec instrument makers & repairers	7311	Precision-instrument makers and repairers
5231	Motor mechanics, auto engineers	7231	Motor vehicle mechanics and fitters
5232	Vehicle body builders and repairers	7213	Sheet-metal workers
5233	Auto electricians	7241	Electrical mechanics fitters and servicers
5234	Vehicle spray painters	7141	Painters and related workers
5241	Electricians, electrical fitters	7137	Building and related electricians
5242	Telecommunications engineers	7244	Telegraph and telephone installers and servicers
5243	Lines repairers and cable jointers	7245	Electrical line installers, repairers and cable jointers
5244	TV, video and audio engineers	7242	Electronics mechanics, fitters and servicers

SOC2000		ISCO88	
5245	Comp engineer, installn & maintnce	7242	Electronics mechanics, fitters and servicers
5249	Elec & electronic engineer n.e.c.	7242	Electronics mechanics, fitters and servicers
5311	Steel erectors	7214	Structural-metal preparers and erectors
5312	Bricklayers, masons	7122	Bricklayers and stonemasons
5313	Roofers, roof tilers and slaters	7131	Roofers
5314	Plumb, hea & ventilating engineers	7136	Plumbers and pipe fitters
5315	Carpenters and joiners	7124	Carpenters and joiners
5316	Glaziers, window fabric and fitters	7135	Glaziers
5319	Construction trades n.e.c.	7121	Builders
5321	Plasterers	7133	Plasterers
5322	Floorers and wall tilers	7132	Floor layers and tile setters
5323	Painters and decorators	7141	Painters and related workers
5411	Weavers and knitters	7432	Weavers, knitters and related workers
5412	Upholsterers	7437	Upholsterers and related workers
5413	Leather and related trades	7442	Shoe-makers and related workers
5414	Tailors and dressmakers	7433	Tailors, dressmakers and hatters
5419	Text, garment & related trades nec.	7430	Textile, garment and related trades workers
5421	Origntrs, compositors & print preps	7341	Compositors, typesetters and related workers
5422	Printers	7341	Compositors, typesetters and related workers
5423	Bookbinders and print finishers	7345	Bookbinders and related workers
5424	Screen printers	7346	Silk-screen, block and craft textile printers
5431	Butchers, meat cutters	7411	Butchers, fishmongers and related food preparers
5432	Bakers, flour confectioners	7412	Bakers, pastry-cooks and confectionery makers
5433	Fishmongers, poultry dressers	7411	Butchers, fishmongers and related food preparers
5434	Chefs, cooks	5122	Cooks
5491	Glss & cermic mkr, decortr, finshr	7320	Potters, glass-makers and related trades workers
5492	Furntre mkr, other crft woodworkers	7422	Cabinetmakers and related workers
5493	Pattern makers (moulds)	7422	Cabinetmakers and related workers
5494	Musicl instrument makers and tuners	7312	Musical-instrument makers and tuners
5495	Goldsmth, silvrsmth, prec stone wrkr	7313	Jewellery and precious-metal workers
5496	Floral arrangers, florists	3471	Decorators and commercial designers
5499	Hand craft occupations n.e.c.	7330	Handicraft workers in wood, textile, leather etc
6111	Nursing auxiliaries and assistants	5132	Institution-based personal care workers
6112	Amb staff (excluding paramedics)	5132	Institution-based personal care workers
6113	Dental nurses	5132	Institution-based personal care workers
6114	Houseprnts and residential wardens	5132	Institution-based personal care workers
6115	Care assistants and home carers	5133	Home-based personal care workers
6121	Nursery nurses	5131	Child-care workers
6122	Childminders and rel occupations	5131	Child-care workers
6123	Playgroup leaders & assistants	5131	Child-care workers
6124	educal assistants	5131	Child-care workers
6131	Veterinary nurses and assistants	3227	Veterinary assistants
6139	Animal care occupations n.e.c.	3227	Veterinary assistants
6211	Sports and leisure assistants	5149	Other personal services workers NEC
6212	Travel agents	4221	Travel agency and related clerks
6213	Travel and tour guides	5113	Travel guides
6214	Air travel assistants	5111	Travel attendants and travel stewards
6215	Rail travel assistants	5112	Transport conductors
6219	Leisure & travel serv occuptns nec.	5110	Travel attendants and related workers
6221	Hairdressers, barbers	5141	Hairdressers, barbers, beauticians and related workers
6222	Beauticians and related occupations	5141	Hairdressers, barbers, beauticians and related workers
6231	Housekprs and related occupations	5121	Housekeepers and related workers
6232	Caretakers	9141	Building caretakers
6291	Undertakers and mortuary assistants	5143	Undertakers and embalmers
6292	Pest control officers	7143	Building structure cleaners
7111	Sales and retail assistants	5220	Shop, stall and market salespersons and demonstrators
7112	Retail cashiers/check-out operators	5220	Shop, stall and market salespersons and demonstrators
7113	Telephone salespersons	9113	Door-to-door and telephone salespersons
7121	Collector salsprns and cred agents	9113	Door-to-door and telephone salespersons

SOC2000		ISCO88	
7122	Debt, rent and other cash collectrs	9153	Vending-machine money collectors, meter readers etc
7123	Rounds(wo)men and van salespersons	9113	Door-to-door and telephone salespersons
7124	Mrkt and street traders and assist	5220	Shop, stall and market salespersons and demonstrators
7125	Merchandisers and window dressers	3471	Decorators and commercial designers
7129	Sales related occupations n.e.c.	3415	Technical and commercial sales representatives
7211	Call centre agents & operators	4220	Client information clerks
7212	Customer care occupations	4220	Client information clerks
8111	Food, drink & tobac process operat	8270	Food and related products machine operators
8112	Glass and ceramics process oprties	8130	Glass, ceramics and related plant operators
8113	Textile process operatives	8260	Textile-, fur- and leather-products machine operators
8114	Chem and related process operatives	8150	Chemical-processing-plant operators
8115	Rubber process operatives	8231	Rubber-products machine operators
8116	Plastics process operatives	8232	Plastic-products machine operators
8117	Mtl mknng & treating procss operative	8120	Metal-processing plant operators
8118	Electroplaters	8223	Metal finishing-, plating- and coating-machine operators
8119	Process operatives n.e.c.	8100	Stationary plant and related operators
8121	Paper and wood machine operatives	8140	Wood-processing- and papermaking-plant operators
8122	Coal mine operatives	8111	Mining plant operators
8123	Quarry workers and related oprtives	8112	Mineral-ore and stone-processing-plant operators
8124	Energy plant operatives	8160	Power-production and related plant operators
8125	Metal working machine operatives	8211	Machine-tool operators
8126	Water and sewerage plant operatives	8163	Incinerator, water-treatment and related plant operators
8129	Plant and machine operatives n.e.c.	8290	Other machine operators NEC
8131	Assemblers (electrical products)	8282	Electrical-equipment assemblers
8132	Assemblers (veh and metal goods)	8281	Mechanical-machinery assemblers
8133	Routine inspectors and testers	8290	Other machine operators NEC
8134	Weighers, graders, sorters	8290	Other machine operators NEC
8135	Tyre, exhaust and windscrn fitters	7231	Motor vehicle mechanics and fitters
8136	Clothing cutters	8269	Textile-, fur- and leather-products machine operators NEC
8137	Sewing machinists	8263	Sewing-machine operators
8138	Routine laboratory testers	8290	Other machine operators NEC
8139	Assemblers and routine oprtives nec.	8290	Other machine operators NEC
8141	Scaffolders, staggers, riggers	7129	Building frame and related trades workers NEC
8142	Road construction operatives	9312	Construction and maintenance labourers: roads, dams etc
8143	Rail constructn & maintnce oprtives	9312	Construction and maintenance labourers: roads, dams etc
8149	Construction operatives n.e.c.	9313	Building construction labourers
8211	Heavy goods vehicle drivers	8324	Heavy truck and lorry drivers
8212	Van drivers	8322	Car, taxi and van drivers
8213	Bus and coach drivers	8323	Bus and tram drivers
8214	Taxi, cab drivers and chauffeurs	8322	Car, taxi and van drivers
8215	Driving instructors	3340	Other teaching associate professionals
8216	Rail transport operatives	8312	Railway brakrs, signallrs and shunters
8217	Seafrr (m navy), brge, lght, boat	8340	Ships' deck crews and related workers
8218	Air transport operatives	9330	Transport labourers and freight handlers
8219	Transport operatives n.e.c.	9330	Transport labourers and freight handlers
8221	Crane drivers	8333	Crane, hoist and related plant operators
8222	Fork-lift truck drivers	8334	Lifting-truck operators
8223	Agricultural machinery drivers	8331	Motorised farm and forestry plant operators
8229	Mobile machine drivers & operatives	8330	Agricultural and other mobile plant operators
9111	Farm workers	9211	Farm-hands and labourers
9112	Forestry workers	9212	Forestry labourers
9119	Fishng & agric reltd occupatns nec.	9210	Agricultural, fishery and related labourers
9121	Labrers build & woodworking trades	9313	Building construction labourers
9129	Lab oth const trades n.e.c.	9312	Construction and maintenance labourers: roads, dams etc
9131	Labourers in foundries	9320	Manufacturing labourers
9132	Indust cleaning process occupations	9132	Helpers and cleaners in offices, hotels etc
9133	Printing machine minders and assist	9320	Manufacturing labourers
9134	Packers, bottlers, canners, fillers	9320	Manufacturing labourers
9139	Labrs process & plant opertns nec.	9320	Manufacturing labourers



SOC2000		ISCO88	
9141	Stevadores, dockers and slingers	9330	Transport labourers and freight handlers
9149	Oth good hndlng & storage occup nec	9330	Transport labourers and freight handlers
9211	Post wrkr, mail sort, msngr, courir	9151	Messengers, package and luggage porters and deliverers
9219	Elementary office occupatns n.e.c.	9151	Messengers, package and luggage porters and deliverers
9221	Hospital porters	9132	Helpers and cleaners in offices, hotels etc
9222	Hotel porters	9150	Messengers, porters, doorkeepers and related workers
9223	Kitchen and catering assistants	9132	Helpers and cleaners in offices, hotels etc
9224	Waiters, waitresses	5123	Waiters, waitresses and bartenders
9225	Bar staff	5123	Waiters, waitresses and bartenders
9226	Leisure and theme park attendants	9152	Doorkeepers, watchpersons and related workers
9229	Elmntry persnal servcs occup n.e.c.	9150	Messengers, porters, doorkeepers and related workers
9231	Window cleaners	9142	Vehicle, window and related cleaners
9232	Road sweepers	9162	Sweepers and related labourers
9233	Cleaners, domestics	9130	Domestic and related helpers, cleaners and launderers
9234	Launderers, dry cleaners, pressers	9133	Hand-launderers and pressers
9235	Refuse and salvage occupations	9161	Garbage collectors
9239	Elementary cleaning occuppns nec.	9162	Sweepers and related labourers
9241	Security guards and rel occupations	9152	Doorkeepers, watchpersons and related workers
9242	Traffic wardens	5169	Protective services workers NEC
9243	School crossing patrol attendants	9152	Doorkeepers, watchpersons and related workers
9244	School mid-day assistants	5131	Child-care workers
9245	Car park attendants	9152	Doorkeepers, watchpersons and related workers
9249	Elementary security occupation nec.	9152	Doorkeepers, watchpersons and related workers
9251	Shelf fillers	5220	Shop, stall and market salespersons and demonstrators
9259	Elementary sales occupations nec.	9151	Messengers, package and luggage porters and deliverers

Note

Where two values of ISCO88 are given for one value of SOC2000 the determining factor is the size of the establishment. If the size of the establishment is ten or more employees then the first ISCO value applies; if less than ten then the second ISCO value applies. The size of the establishment is recorded in the LFS variables MPNE02 , MPNS02 and equivalents.

**Annex III (b) – SOC2010 to ISCO-08**

The conversion from SOC2010 to ISCO-08 is carried out during LFS processing using a probabilistic mapping tool. For further details and to request copies of the mapping tool (available in SAS and SPSS) contact: sean.milburn@ons.gov.uk

For details of ISCO-08 see: <http://www.ilo.org/public/english/bureau/stat/isco/isco08/>

**Annex IV a – Eurostat variable names and their UK LFS equivalents (2012 to 2013)**

The UK LFS historically has tended to rename Eurostat variables. Generally this involves adding an ‘E’ prefix and truncating the Eurostat name, for example COBFATH (country of birth of father) becomes ECOBFAT.

Col	Eurostat name	LFS name	Description
1-2	HHSEQNUM	EPERSNO	Person number within household
3	HHLINK	ERELHOH	Relationship to head of household
4-5	HHSPOU	ESPOUSE	Sequence number of spouse or partner
6-7	HHFATH	EFATHER	Sequence number of father
8-9	HHMOTH	EMOTHER	Sequence number of mother
10	SEX	ESEX	Sex
11-14	YEARBIR	EYOB	Year of birth
15	DATEBIR	EDOB	Date of birth in relation to end of ref period
16	MARSTAT	EMARSTAT	Marital status
17-18	NATIONAL	ENAT	Nationality
19-20	REARESID	EYRSRES	Years of residence
21-22	COUNTRYB	ECOB	Country of birth
23	PROXY	EPROXY	Nature of participation in survey
24	WSTATOR	EWKSTATR	Work status in ref week
25-26	NOWKREAS	ERESAWYR	Reason for not working but having job
27	STAPRO	ESTATR	Professional status
28	SIGNISAL	EFISAL	Continuing receipt of wage or salary
29-31	NACE3D	ENACE08	Industry / Economic activity of local unit
32-35	ISCO4D	EISCOMR	Occupation
36	SUPVISOR	ESUPVIS	Supervisory responsibilities
37-38	SIZEFIRM	ENUMPR	Number of persons working at the local unit / establishment
39-40	COUNTRYW	ECONWRK	Country of place of work
41-42	REGIONW	EREGWK10	Region of place of work – NUTS10 level 2
43-46	YSTARTWK	EYRSTRTR	Year started with current employer or as self employed
47-48	MSTARTWK	EMNSTRTR	Month started with current employer or as self employed
49	WAYJFOUN	EHOWGET	Involvement of public employment office in job find
50	FTPT	EFTPTWKR	Full, part-time distinction (main job)
51	FTPTREAS	EYPTJOB	Reasons for part-time work
52	TEMP	EPERMR	Permanency of main job
53	TEMPREAS	EWHYTMP	Reasons for having a temporary job / work contract of limited duration
54	TEMPDUR	EDURTMPR	Total duration of temporary job
55	TEMPAGCY	ETMPCON	Contract with a temporary employment agency
56	SHIFTWK	ESHIFTR	Shiftwork (in main job)
57	EVENWK	EEVENR	Evening work (in main job)
58	NIGHTWK	ENIGHTR	Night work (in main job)
59	SATWK	ESATR	Saturday work (in main job)
60	SUNWK	ESUNR	Sunday work (in main job)
61-62	HWUSUAL	EUSUHRR	Number of hours per week usually worked
63-64	HWACTUAL	EACTHRR	Number of hours actually worked during reference week
65-66	HWOVERP	EACTPOT	Whether did paid overtime during reference week (in main job)
67-68	HWOVERPU	EACTUOT	Whether did unpaid overtime during reference week (in main job)
69-70	HOURREAS	EWHYDIFR	Main reason actual hours differ from usual hours
71	WISHMORE	EMHRSR	Wish to work usually more than current number of hours
72	WAYMORE	EWAYHRS	Way in which want to work more hours
73-74	HWWISH	ENUMHRS R	Total number of hours respondent would like to work.
75	HOMEWK	EHOMER	Whether works at home
76	LOOKOJ	EADDWKR	Whether looking for another job

## Eurostat variable names and their UK LFS equivalents (2012 to 2013) cont'd

Col	Eurostat name	LFS name	Description
77	LOOKREAS	EADDREA	Reason for looking for another job
78	EXIST2J	ESECJOBR	Existence of more than one job or business
79	STAPRO2J	ESTAT2R	Professional status in second job
80-81	NACE2J2D	ENACE208	Economic activity of the local unit (in second job)
82-83	HWACTUA2	EACTHR2R	Number of hours actually worked during reference week in second job
84	EXISTPR	EEVWKR	Existence of previous employment experience
85-88	YEARPR	EYRLASTR	Year in which respondent last worked
89-90	MONTHPR	EMNLASTR	Month in which respondent last worked
91-92	LEAVRS	EWHYLFTR	Main reason for leaving last job or business
93	STAPROPR	ESTATLR	Professional status in last job
94-95	NACEPR2D	ENACEL08	Economic activity of the local unit in which respondent last worked
96-98	ISCOPE3D	EISCOLR	Occupation of last job
99	SEEKWORK	ELOOKR	Seeking employment during previous four weeks
100	SEEKREAS	ENOLWM	Reasons for not seeking work
101	SEEKTYPE	ETYMPSR	Type of employment sought (or found)
102	SEEKDUR	ELKTIMR	Duration of search for employment
103	METHODA	EMETH1R	Whether contacted public employment office to find work
104	METHODB	EMETH2R	Whether contacted private employment office to find work
105	METHODC	EMETH3R	Whether applied to employers directly
106	METHODD	EMETH4R	Whether asked friends, relatives, trade unions etc
107	METHODE	EMETH5R	Whether inserted or answered advertisements in newspapers or journals
108	METHODF	EMETH6R	Whether studied advertisements in newspapers or journals
109	METHODG	EMETH7R	Whether took a test, interview or examination
110	METHODH	EMETH8R	Whether looked for land, premises or equipment
111	METHODI	EMETH9R	Whether looked for permits, licences or financial resources
112	METHODJ	EMETH10R	Awaiting the results of an application for a job
113	METHODK	EMETH11R	Waiting for a call from a public employment office
114	METHODL	EMETH12R	Awaiting the results of a competition for recruitment to the public sector
115	METHODM	EMETH13R	Other method used
116	WANTWORK	ELIKWKR	Willingness to work for person not seeking employment
117	AVAILBLE	EAVALWKR	Availability to start working within two weeks
118	AVAIRES	EAVALREA	Reasons for not being available to start working within two weeks
119	PRESEEK	EBEFORER	Situation immediately before person started to seek employment
120	NEEDCARE	ENECARE	Need for care facilities
121	REGISTER	EREGPUB	Registration at a public employment office
122	MAINSTAT	ESTATUS	Main labour status
123	EDUCSTAT	EDUCSTA	Student or apprentice in regular education during the last four weeks
124	EDUCLEVEL	EDUCLEV	Level of this education or training
125-127	EDUCFIELD	EDUCFLD	Field of this education or training
128	COURATT	ECOURA	Attendance at courses, seminars etc outside regular education system
129-131	COURLEN	ECOURL	Number of hours spent on all taught-learning activities within last four weeks
132	COURPURP	ECOURP	Purpose of most recent taught-learning activity
133-135	COURFIELD	ECOURF	Field of most recent taught-learning activity
136	COURWORH	ECOURW	Whether most recent taught-learning took place during paid working hours
137-138	HATLEVEL	EHATLEV	Highest level of education or training successfully completed
139-141	HATFIELD	EHATFLD	Field of highest level of education or training successfully completed
142-145	HATYEAR	EHATYR	Year when highest level of education or training was successfully completed
146	WSTAT1Y	ESITONE	Situation regarding activity one year ago
147	STAPRO1Y	ESTATOR	Professional status one year ago
148-149	NACE1Y2D	ENACEO08	Economic activity of local unit in which respondent employed one year ago
150-151	COUNTRY1Y	ECTYO	Country of residence one year ago
152-153	REGION1Y	EREGO10	Region of residence one year ago – NUTS10 level 2
154-155	INCDECIL	ENETMN	Monthly (take-home) pay from main job

Eurostat variable names and their UK LFS equivalents (2012 to 2013) cont'd

Col	Eurostat name	LFS name	Description
156-159	REFYEAR	EYEAR	Year of survey
160-161	REFWEEK	EREFWK	Reference week
162-163	INTWEEK	EINTWK	Interview week
164-165	COUNTRY	ESTATE	Country
166-167	REGION	EREGN10	Region of household – NUTS10 level 2
168	DEGURBA	EURBAN	Degree of urbanisation
169-174	HHNUM	ESERIAL	Serial number of household
175	HHTYPE	ETYPHLD	Type of household
176	HHINST	ETYPINS	Type of institution
177-182	COEFFY	EWEIGHT	Weight, yearly
183-188	COEFFQ	EQWTyy	Weight, quarterly
189-194	COEFFH	EQHHWT	Weight, yearly household
195	INTWAVE	EWAVE	Sequence number of the survey wave
196	INTQUEST	EINTQUES	Questionnaire used
260-262	REG3DW	EREGWK103	Region of place of work – NUTS10 level 3 (optional)
263-265	REG3D1Y	EREGO103	Region of residence one year ago – NUTS10 level 3 (optional)
266-268	REG3D	EREGN103	Region of residence – NUTS10 level 3 (optional)

**Annex IV b – Eurostat variable names and their UK LFS equivalents (2014)**

The UK LFS historically has tended to rename Eurostat variables. Generally this involves adding an ‘E’ prefix and truncating the Eurostat name, for example COBFATH (country of birth of father) becomes ECOBFAT.

Col	Eurostat name	LFS name	Description
1-2	HHSEQNUM	EPERSNO	Person number within household
3	HHLINK	ERELHOH	Relationship to head of household
4-5	HHSPOU	ESPOUSE	Sequence number of spouse or partner
6-7	HHFATH	EFATHER	Sequence number of father
8-9	HHMOTH	EMOTHER	Sequence number of mother
10	SEX	ESEX	Sex
11-14	YEARBIR	EYOB	Year of birth
15	DATEBIR	EDOB	Date of birth in relation to end of ref period
16	MARSTAT	EMARSTAT	Marital status
17-18	NATIONAL	ENAT	Nationality
19-20	REARESID	EYRSRES	Years of residence
21-22	COUNTRYB	ECOB	Country of birth
23	PROXY	EPROXY	Nature of participation in survey
24	WSTATOR	EWKSTATR	Work status in ref week
25-26	NOWKREAS	ERESAWYR	Reason for not working but having job
27	STAPRO	ESTATR	Professional status
28	SIGNISAL	EFISAL	Continuing receipt of wage or salary
29-31	NACE3D	ENACE08	Industry / Economic activity of local unit
32-35	ISCO4D	EISCOMR	Occupation
36	SUPVISOR	ESUPVIS	Supervisory responsibilities
37-38	SIZEFIRM	ENUMPR	Number of persons working at the local unit / establishment
39-40	COUNTRYW	ECONWRK	Country of place of work
41-42	REGIONW	EREGWK10	Region of place of work – NUTS10 level 2
43-46	YSTARTWK	EYRSTRTR	Year started with current employer or as self employed
47-48	MSTARTWK	EMNSTRTR	Month started with current employer or as self employed
49	WAYJFOUN	EHOWGET	Involvement of public employment office in job find
50	FTPT	EFTPTWKR	Full, part-time distinction (main job)
51	FTPTREAS	EYPTJOB	Reasons for part-time work
52	TEMP	EPERMR	Permanency of main job
53	TEMPREAS	EWHYTMP	Reasons for having a temporary job / work contract of limited duration
54	TEMPDUR	EDURTMPR	Total duration of temporary job
55	TEMPAGCY	ETMPCON	Contract with a temporary employment agency
56	SHIFTWK	ESHIFTR	Shiftwork (in main job)
57	EVENWK	EEVENR	Evening work (in main job)
58	NIGHTWK	ENIGHTR	Night work (in main job)
59	SATWK	ESATR	Saturday work (in main job)
60	SUNWK	ESUNR	Sunday work (in main job)
61-62	HWUSUAL	EUSUHRR	Number of hours per week usually worked
63-64	HWACTUAL	EACTHRR	Number of hours actually worked during reference week
65-66	HWOVERP	EACTPOT	Whether did paid overtime during reference week (in main job)
67-68	HWOVERPU	EACTUOT	Whether did unpaid overtime during reference week (in main job)
69-70	HOURREAS	EWHYDIFR	Main reason actual hours differ from usual hours
71	WISHMORE	EMHRSR	Wish to work usually more than current number of hours
72	WAYMORE	EWAYHRS	Way in which want to work more hours
73-74	HWWISH	ENUMHRS	Total number of hours respondent would like to work.
75	HOMEWK	EHOMER	Whether works at home
76	LOOKOJ	EADDWKR	Whether looking for another job

Eurostat variable names and their UK LFS equivalents (2014) cont'd

Col	Eurostat name	LFS name	Description
77	LOOKREAS	EADDREA	Reason for looking for another job
78	EXIST2J	ESECJOBR	Existence of more than one job or business
79	STAPRO2J	ESTAT2R	Professional status in second job
80-81	NACE2J2D	ENACE208	Economic activity of the local unit (in second job)
82-83	HWACTUA2	EACTHR2R	Number of hours actually worked during reference week in second job
84	EXISTPR	EEVWKR	Existence of previous employment experience
85-88	YEARPR	EYRLASTR	Year in which respondent last worked
89-90	MONTHPR	EMNLASTR	Month in which respondent last worked
91-92	LEAVRS	EWHYLFTR	Main reason for leaving last job or business
93	STAPROPR	ESTATLR	Professional status in last job
94-95	NACEPR2D	ENACEL08	Economic activity of the local unit in which respondent last worked
96-98	ISCOPR3D	EISCOLR	Occupation of last job
99	SEEKWORK	ELOOKR	Seeking employment during previous four weeks
100	SEEKREAS	ENOLWM	Reasons for not seeking work
101	SEEKTYPE	ETYMPSR	Type of employment sought (or found)
102	SEEKDUR	ELKTIMR	Duration of search for employment
103	METHODA	EMETH1R	Whether contacted public employment office to find work
104	METHODB	EMETH2R	Whether contacted private employment office to find work
105	METHODC	EMETH3R	Whether applied to employers directly
106	METHODD	EMETH4R	Whether asked friends, relatives, trade unions etc
107	METHODE	EMETH5R	Whether inserted or answered advertisements in newspapers or journals
108	METHODF	EMETH6R	Whether studied advertisements in newspapers or journals
109	METHODG	EMETH7R	Whether took a test, interview or examination
110	METHODH	EMETH8R	Whether looked for land, premises or equipment
111	METHODI	EMETH9R	Whether looked for permits, licences or financial resources
112	METHODJ	EMETH10R	Awaiting the results of an application for a job
113	METHODK	EMETH11R	Waiting for a call from a public employment office
114	METHODL	EMETH12R	Awaiting the results of a competition for recruitment to the public sector
115	METHODM	EMETH13R	Other method used
116	WANTWORK	ELIKWKR	Willingness to work for person not seeking employment
117	AVAILBLE	EAVALWKR	Availability to start working within two weeks
118	AVAIRES	EAVALREA	Reasons for not being available to start working within two weeks
119	PRESEEK	EBEFORER	Situation immediately before person started to seek employment
120	NEEDCARE	ENECARE	Need for care facilities
121	REGISTER	EREGPUB	Registration at a public employment office
122	MAINSTAT	ESTATUS	Main labour status
123	EDUCSTAT	EDUCSTA	Student or apprentice in regular education during the last four weeks
124	-	(Blank)	(Formerly EDUCLEVL, see 209)
125-127	-	(Blank)	(Formerly EDUCFILD, discontinued 2014)
128	COURATT	ECOURA	Attendance at courses, seminars etc outside regular education system
129-131	COURLEN	ECOURL	Number of hours spent on all taught-learning activities within last four weeks
132	COURPURP	ECOURP	Purpose of most recent taught-learning activity
133-135	COURFILD	ECOURF	Field of most recent taught-learning activity
136	COURWORH	ECOURW	Whether most recent taught-learning took place during paid working hours
137-138	-	(Blank)	(Formerly HATLEVEL, see 197-199)
139-141	-	(Blank)	(Formerly HATFIELD, see 205-208)
142-145	-	(Blank)	(Formerly HATYEAR, see 200-203)
146	WSTAT1Y	ESITONE	Situation regarding activity one year ago
147	STAPRO1Y	ESTATOR	Professional status one year ago
148-149	NACE1Y2D	ENACEO08	Economic activity of local unit in which respondent employed one year ago
150-151	COUNTRY1Y	ECTYO	Country of residence one year ago
152-153	REGION1Y	EREGO10	Region of residence one year ago – NUTS10 level 2
154-155	INCDECIL	ENETMN	Monthly (take-home) pay from main job

Eurostat variable names and their UK LFS equivalents (2014) cont'd

Col	Eurostat name	LFS name	Description
156-159	REFYEAR	EYEAR	Year of survey
160-161	REFWEEK	EREFWK	Reference week
162-163	INTWEEK	EINTWK	Interview week
164-165	COUNTRY	ESTATE	Country
166-167	REGION	EREGN10	Region of household – NUTS10 level 2
168	DEGURBA	EURBAN	Degree of urbanisation
169-174	HHNUM	ESERIAL	Serial number of household
175	HHTYPE	ETYPHLD	Type of household
176	HHINST	ETYPINS	Type of institution
177-182	COEFFY	EWEIGHT	Weight, yearly
183-188	COEFFQ	EQWTyy	Weight, quarterly
189-194	COEFFH	EQHHWT	Weight, yearly household
195	INTWAVE	EWAVE	Sequence number of the survey wave
196	INTQUEST	EINTQUES	Questionnaire used
197-199	HATLEVEL	EHATLEV14	Educational attainment level
200-203	HATYEAR	EHATYR14	Year when highest level of education completed
204	HATVOC	EHATVOC14	Orientation of programme completed at highest level (i.e. HATLEVEL)
205-208	HATFIELD	EHATFLD14	Field of programme completed at highest level (i.e. HATLEVEL)
209	EDUCLEVL	EDUCLEV14	Level of current education in which person enrolled
210	EDUCVOC	EDUCVOC14	Orientation of programme on which person enrolled (i.e. EDUCLEVL)
260-262	REG3DW	EREGWK103	Region of place of work – NUTS10 level 3 (optional)
263-265	REG3D1Y	EREGO103	Region of residence one year ago – NUTS10 level 3 (optional)
266-268	REG3D	EREGN103	Region of residence – NUTS10 level 3 (optional)

**Annex IV c – Eurostat variable names and their UK LFS equivalents (2015)**

The UK LFS historically has tended to rename Eurostat variables. Generally this involves adding an ‘E’ prefix and truncating the Eurostat name, for example COBFATH (country of birth of father) becomes ECOBFAT.

Col	Eurostat name	LFS name	Description
1-2	HHSEQNUM	EPERSNO	Person number within household
3	HHLINK	ERELHOH	Relationship to head of household
4-5	HHSPOU	ESPOUSE	Sequence number of spouse or partner
6-7	HHFATH	EFATHER	Sequence number of father
8-9	HHMOTH	EMOTHER	Sequence number of mother
10	SEX	ESEX	Sex
11-14	YEARBIR	EYOB	Year of birth
15	DATEBIR	EDOB	Date of birth in relation to end of ref period
16	MARSTAT	EMARSTAT	Marital status
17-18	NATIONAL	ENAT	Nationality
19-20	REARESID	EYRSRES	Years of residence
21-22	COUNTRYB	ECOB	Country of birth
23	PROXY	EPROXY	Nature of participation in survey
24	WSTATOR	EWKSTATR	Work status in ref week
25-26	NOWKREAS	ERESAWYR	Reason for not working but having job
27	STAPRO	ESTATR	Professional status
28	SIGNISAL	EFISAL	Continuing receipt of wage or salary
29-31	NACE3D	ENACE08	Industry / Economic activity of local unit
32-35	ISCO4D	EISCOMR	Occupation
36	SUPVISOR	ESUPVIS	Supervisory responsibilities
37-38	SIZEFIRM	ENUMPR	Number of persons working at the local unit / establishment
39-40	COUNTRYW	ECONWRK	Country of place of work
41-42	REGIONW	EREGWK13	Region of place of work – NUTS13 level 2
43-46	YSTARTWK	EYRSTRTR	Year started with current employer or as self employed
47-48	MSTARTWK	EMNSTRTR	Month started with current employer or as self employed
49	WAYJFOUN	EHOWGET	Involvement of public employment office in job find
50	FTPT	EFTPTWKR	Full, part-time distinction (main job)
51	FTPTREAS	EYPTJOB	Reasons for part-time work
52	TEMP	EPERMR	Permanency of main job
53	TEMPREAS	EWHYTMP	Reasons for having a temporary job / work contract of limited duration
54	TEMPDUR	EDURTMPR	Total duration of temporary job
55	TEMPAGCY	ETMPCON	Contract with a temporary employment agency
56	SHIFTWK	ESHIFTR	Shiftwork (in main job)
57	EVENWK	EEVENR	Evening work (in main job)
58	NIGHTWK	ENIGHTR	Night work (in main job)
59	SATWK	ESATR	Saturday work (in main job)
60	SUNWK	ESUNR	Sunday work (in main job)
61-62	HWUSUAL	EUSUHRR	Number of hours per week usually worked
63-64	HWACTUAL	EACTHRR	Number of hours actually worked during reference week
65-66	HWOVERP	EACTPOT	Whether did paid overtime during reference week (in main job)
67-68	HWOVERPU	EACTUOT	Whether did unpaid overtime during reference week (in main job)
69-70	HOURREAS	EWHYDIFR	Main reason actual hours differ from usual hours
71	WISHMORE	EMHRSR	Wish to work usually more than current number of hours
72	WAYMORE	EWAYHRS	Way in which want to work more hours
73-74	HWWISH	ENUMHRS R	Total number of hours respondent would like to work.
75	HOMEWK	EHOMER	Whether works at home
76	LOOKOJ	EADDWKR	Whether looking for another job



## Eurostat variable names and their UK LFS equivalents (2015) cont'd

	<b>Eurostat name</b>	<b>LFS name</b>	<b>Description</b>
	77 LOOKREAS	EADDREA	Reason for looking for another job
	78 EXIST2J	ESECJOBR	Existence of more than one job or business
	79 STAPRO2J	ESTAT2R	Professional status in second job
80-81	NACE2J2D	ENACE208	Economic activity of the local unit (in second job)
82-83	HWACTUA2	EACTHR2R	Number of hours actually worked during reference week in second job
	84 EXISTPR	EEVWKR	Existence of previous employment experience
85-88	YEARPR	EYRLASTR	Year in which respondent last worked
89-90	MONTHPR	EMNLASTR	Month in which respondent last worked
91-92	LEAVRS	EWHYLFTR	Main reason for leaving last job or business
	93 STAPROPR	ESTATLR	Professional status in last job
94-95	NACEPR2D	ENACEL08	Economic activity of the local unit in which respondent last worked
96-98	ISCOPR3D	EISCOLR	Occupation of last job
	99 SEEKWORK	ELOOKR	Seeking employment during previous four weeks
100	SEEKREAS	ENOLWM	Reasons for not seeking work
101	SEEKTYPE	ETYMPSR	Type of employment sought (or found)
102	SEEKDUR	ELKTIMR	Duration of search for employment
103	METHODA	EMETH1R	Whether contacted public employment office to find work
104	METHODB	EMETH2R	Whether contacted private employment office to find work
105	METHODC	EMETH3R	Whether applied to employers directly
106	METHODD	EMETH4R	Whether asked friends, relatives, trade unions etc
107	METHODE	EMETH5R	Whether inserted or answered advertisements in newspapers or journals
108	METHODF	EMETH6R	Whether studied advertisements in newspapers or journals
109	METHODG	EMETH7R	Whether took a test, interview or examination
110	METHODH	EMETH8R	Whether looked for land, premises or equipment
111	METHODI	EMETH9R	Whether looked for permits, licences or financial resources
112	METHODJ	EMETH10R	Awaiting the results of an application for a job
113	METHODK	EMETH11R	Waiting for a call from a public employment office
114	METHODL	EMETH12R	Awaiting the results of a competition for recruitment to the public sector
115	METHODM	EMETH13R	Other method used
116	WANTWORK	ELIKWKR	Willingness to work for person not seeking employment
117	AVAILBLE	EAVALWKR	Availability to start working within two weeks
118	AVAIRES	EAVALREA	Reasons for not being available to start working within two weeks
119	PRESEEK	EBEFORER	Situation immediately before person started to seek employment
120	NEEDCARE	ENECARE	Need for care facilities
121	REGISTER	EREGPUB	Registration at a public employment office
122	MAINSTAT	ESTATUS	Main labour status
123	EDUCSTAT	EDUCSTA	Student or apprentice in regular education during the last four weeks
124	-	(Blank)	(Formerly EDUCLEVL, see 209)
125-127	-	(Blank)	(Formerly EDUCFILD, discontinued 2014)
128	COURATT	ECOURA	Attendance at courses, seminars etc outside regular education system
129-131	COURLEN	ECOURL	Number of hours spent on all taught-learning activities within last four weeks
132	COURPURP	ECOURP	Purpose of most recent taught-learning activity
133-135	COURFILD	ECOURF	Field of most recent taught-learning activity
136	COURWORH	ECOURW	Whether most recent taught-learning took place during paid working hours
137-138	-	(Blank)	(Formerly HATLEVEL, see 197-199)
139-141	-	(Blank)	(Formerly HATFIELD, see 205-208)
142-145	-	(Blank)	(Formerly HATYEAR, see 200-203)
146	WSTAT1Y	ESITONE	Situation regarding activity one year ago
147	STAPRO1Y	ESTATOR	Professional status one year ago
148-149	NACE1Y2D	ENACEO08	Economic activity of local unit in which respondent employed one year ago
150-151	COUNTRY1Y	ECTYO	Country of residence one year ago
152-153	REGION1Y	EREGO13	Region of residence one year ago – NUTS13 level 2
154-155	INCDECIL	ENETMN	Monthly (take-home) pay from main job

Eurostat variable names and their UK LFS equivalents (2015) cont'd

Col	Eurostat name	LFS name	Description
156-159	REFYEAR	EYEAR	Year of survey
160-161	REFWEEK	EREFWK	Reference week
162-163	INTWEEK	EINTWK	Interview week
164-165	COUNTRY	ESTATE	Country
166-167	REGION	EREGN13	Region of household – NUTS13 level 2
168	DEGURBA	EURBAN	Degree of urbanisation
169-174	HHNUM	ESERIAL	Serial number of household
175	HHTYPE	ETYPHLD	Type of household
176	HHINST	ETYPINS	Type of institution
177-182	COEFFY	EWEIGHT	Weight, yearly
183-188	COEFFQ	EQWTyy	Weight, quarterly
189-194	COEFFH	EQHHWT	Weight, yearly household
195	INTWAVE	EWAVE	Sequence number of the survey wave
196	INTQUEST	EINTQUES	Questionnaire used
197-199	HATLEVEL	EHATLEV15	Educational attainment level
200-203	HATYEAR	EHATYR15	Year when highest level of education completed
204	HATVOC	EHATVOC15	Orientation of programme completed at highest level (i.e. HATLEVEL)
205-208	HATFIELD	EHATFLD15	Field of programme completed at highest level (i.e. HATLEVEL)
209	EDUCLEVL	EDUCLEV15	Level of current education in which person enrolled
210	EDUCVOC	EDUCVOC15	Orientation of programme on which person enrolled (i.e. EDUCLEVL)
260-262	REG3DW	EREGWK133	Region of place of work – NUTS13 level 3 (optional)
263-265	REG3D1Y	EREGO133	Region of residence one year ago – NUTS13 level 3 (optional)
266-268	REG3D	EREGN133	Region of residence – NUTS13 level 3 (optional)

**Annex IV d – Eurostat variable names and their UK LFS equivalents (2016)**

The UK LFS historically has tended to rename Eurostat variables. Generally this involves adding an ‘E’ prefix and truncating the Eurostat name, for example COBFATH (country of birth of father) becomes ECOBFAT.

Col	Eurostat name	LFS name	Description
1-2	HHSEQNUM	EPERSNO	Person number within household
3	HHLINK	ERELHOH	Relationship to head of household
4-5	HHSPOU	ESPOUSE	Sequence number of spouse or partner
6-7	HHFATH	EFATHER	Sequence number of father
8-9	HHMOTH	EMOTHER	Sequence number of mother
10	SEX	ESEX	Sex
11-14	YEARBIR	EYOB	Year of birth
15	DATEBIR	EDOB	Date of birth in relation to end of ref period
16	MARSTAT	EMARSTAT	Marital status
17-18	NATIONAL	ENAT	Nationality
19-20	REARESID	EYRSRES	Years of residence
21-22	COUNTRYB	ECOB	Country of birth
23	PROXY	EPROXY	Nature of participation in survey
24	WSTATOR	EWKSTATR	Work status in ref week
25-26	NOWKREAS	ERESAWYR	Reason for not working but having job
27	STAPRO	ESTATR	Professional status
28	SIGNISAL	EFISAL	Continuing receipt of wage or salary
29-31	NACE3D	ENACE08	Industry / Economic activity of local unit
32-35	ISCO4D	EISCOMR	Occupation
36	SUPVISOR	ESUPVIS	Supervisory responsibilities
37-38	SIZEFIRM	ENUMPR	Number of persons working at the local unit / establishment
39-40	COUNTRYW	ECONWRK	Country of place of work
41-42	REGIONW	EREGWKR	Region of place of work
43-46	YSTARTWK	EYRSTRTR	Year started with current employer or as self employed
47-48	MSTARTWK	EMNSTRTR	Month started with current employer or as self employed
49	WAYJFOUN	EHOWGET	Involvement of public employment office in job find
50	FTPT	EFTPTWKR	Full, part-time distinction (main job)
51	FTPTREAS	EYPTJOB	Reasons for part-time work
52	TEMP	EPERMR	Permanency of main job
53	TEMPREAS	EWHYTMP	Reasons for having a temporary job / work contract of limited duration
54	TEMPDUR	EDURTMPR	Total duration of temporary job
55	TEMPAGCY	ETMPCON	Contract with a temporary employment agency
56	SHIFTWK	ESHIFTR	Shiftwork (in main job)
57	EVENWK	EEVENR	Evening work (in main job)
58	NIGHTWK	ENIGHTR	Night work (in main job)
59	SATWK	ESATR	Saturday work (in main job)
60	SUNWK	ESUNR	Sunday work (in main job)
61-62	HWUSUAL	EUSUHRR	Number of hours per week usually worked
63-64	HWACTUAL	EACTHRR	Number of hours actually worked during reference week
65-66	HWOVERP	EACTPOT	Whether did paid overtime during reference week (in main job)
67-68	HWOVERPU	EACTUOT	Whether did unpaid overtime during reference week (in main job)
69-70	HOURREAS	EWHYDIFR	Main reason actual hours differ from usual hours
71	WISHMORE	EMHRSR	Wish to work usually more than current number of hours
72	WAYMORE	EWAYHRS	Way in which want to work more hours
73-74	HWWISH	ENUMHRS	Total number of hours respondent would like to work.
75	HOMEWK	EHOMER	Whether works at home
76	LOOKOJ	EADDWKR	Whether looking for another job

## Eurostat variable names and their UK LFS equivalents (2016) cont'd

	<b>Eurostat name</b>	<b>LFS name</b>	<b>Description</b>
	77 LOOKREAS	EADDREA	Reason for looking for another job
	78 EXIST2J	ESECJOBR	Existence of more than one job or business
	79 STAPRO2J	ESTAT2R	Professional status in second job
80-81	NACE2J2D	ENACE208	Economic activity of the local unit (in second job)
82-83	HWACTUA2	EACTHR2R	Number of hours actually worked during reference week in second job
	84 EXISTPR	EEVWKR	Existence of previous employment experience
85-88	YEARPR	EYRLASTR	Year in which respondent last worked
89-90	MONTHPR	EMNLASTR	Month in which respondent last worked
91-92	LEAVRS	EWHYLFTR	Main reason for leaving last job or business
	93 STAPROPR	ESTATLR	Professional status in last job
94-95	NACEPR2D	ENACEL08	Economic activity of the local unit in which respondent last worked
96-98	ISCOPE3D	EISCOLR	Occupation of last job
	99 SEEKWORK	ELOOKR	Seeking employment during previous four weeks
100	SEEKREAS	ENOLWM	Reasons for not seeking work
101	SEEKTYPE	ETYMPSR	Type of employment sought (or found)
102	SEEKDUR	ELKTIMR	Duration of search for employment
103	METHODA	EMETH1R	Whether contacted public employment office to find work
104	METHODB	EMETH2R	Whether contacted private employment office to find work
105	METHODC	EMETH3R	Whether applied to employers directly
106	METHODD	EMETH4R	Whether asked friends, relatives, trade unions etc
107	METHODE	EMETH5R	Whether inserted or answered advertisements in newspapers or journals
108	METHODF	EMETH6R	Whether studied advertisements in newspapers or journals
109	METHODG	EMETH7R	Whether took a test, interview or examination
110	METHODH	EMETH8R	Whether looked for land, premises or equipment
111	METHODI	EMETH9R	Whether looked for permits, licences or financial resources
112	METHODJ	EMETH10R	Awaiting the results of an application for a job
113	METHODK	EMETH11R	Waiting for a call from a public employment office
114	METHODL	EMETH12R	Awaiting the results of a competition for recruitment to the public sector
115	METHODM	EMETH13R	Other method used
116	WANTWORK	ELIKWKR	Willingness to work for person not seeking employment
117	AVAILBLE	EVALWKR	Availability to start working within two weeks
118	AVAIRES	EVALREA	Reasons for not being available to start working within two weeks
119	PRESEEK	EBEFORER	Situation immediately before person started to seek employment
120	NEEDCARE	ENECARE	Need for care facilities
121	REGISTER	EREGPUB	Registration at a public employment office
122	MAINSTAT	ESTATUS	Main labour status
123	EDUCSTAT	EDUCSTA16	Student or apprentice in regular education during the last four weeks
124	-	(Blank)	(Formerly EDUCLEVL, see 209)
125-127	-	(Blank)	(Formerly EDUCFILD, discontinued 2014)
128	COURATT	ECOURA16	Attendance at courses, seminars etc outside regular education system
129-131	COURLEN	ECOURL	Number of hours spent on all taught-learning activities within last 4 weeks
132	COURPURP	ECOURP	Purpose of most recent taught-learning activity
133-135	COURFILD	ECOURF16	Field of most recent taught-learning activity
136	COURWORH	ECOURW	Whether most recent taught-learning took place during paid working hours
137-138	-	(Blank)	(Formerly HATLEVEL, see 197-199)
139-141	-	(Blank)	(Formerly HATFIELD, see 205-208)
142-145	-	(Blank)	(Formerly HATYEAR, see 200-203)
146	WSTAT1Y	ESITONE	Situation regarding activity one year ago
147	STAPRO1Y	ESTATOR	Professional status one year ago
148-149	NACE1Y2D	ENACEO08	Economic activity of local unit in which respondent employed one year ago
150-151	COUNTRY1Y	ECTYO	Country of residence one year ago
152-153	REGION1Y	EREGO00	Region of residence one year ago
154-155	INCDECIL	ENETMN	Monthly (take-home) pay from main job

Eurostat variable names and their UK LFS equivalents (2016) cont'd

Col	Eurostat name	LFS name	Description
156-159	REFYEAR	EYEAR	Year of survey
160-161	REFWEEK	EREFWK	Reference week
162-163	INTWEEK	EINTWK	Interview week
164-165	COUNTRY	ESTATE	Country
166-167	REGION	EREGN00	Region of household
168	DEGURBA	EURBAN	Degree of urbanisation
169-174	HHNUM	ESERIAL	Serial number of household
175	HHTYPE	ETYPHLD	Type of household
176	HHINST	ETYPINS	Type of institution
177-182	COEFFY	EWEIGHT	Weight, yearly
183-188	COEFFQ	EQWTyy	Weight, quarterly
189-194	COEFFH	EQHHWT	Weight, yearly household
195	INTWAVE	EWAVE	Sequence number of the survey wave
196	INTQUEST	EINTQUES	Questionnaire used
197-199	HATLEVEL	EHATLEV15	Educational attainment level
200-203	HATYEAR	EHATYR15	Year when highest level of education completed
204	HATVOC	EHATVOC15	Orientation of programme completed at highest level (i.e. HATLEVEL)
205-208	HATFIELD	EHATFLD16	Field of programme completed at highest level (i.e. HATLEVEL)
209	EDUCLEVL	EDUCLEV16	Level of current education in which person enrolled
210	EDUCVOC	EDUCVOC15	Orientation of programme on which person enrolled (i.e. EDUCLEVL)
260-262	REG3DW	EREGWK133	Region of place of work – NUTS13 level 3 (optional)
263-265	REG3D1Y	EREGO133	Region of residence one year ago – NUTS13 level 3 (optional)
266-268	REG3D	EREGN133	Region of residence – NUTS13 level 3 (optional)